

## High-side driver with CurrentSense analog feedback for automotive applications

Datasheet - production data

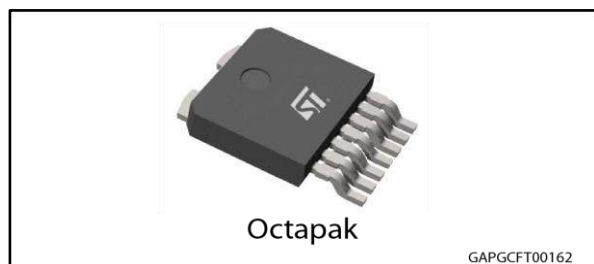

- Self limiting of fast thermal transients
- Loss of ground and loss of  $V_{CC}$
- Reverse battery
- Electrostatic discharge protection

### Applications

Specially intended for Automotive smart power distribution, glow plugs, heating systems, DC motors, relay replacement and high power resistive and inductive actuators.

### Features

|                                   |            |              |
|-----------------------------------|------------|--------------|
| Max transient supply voltage      | $V_{CC}$   | 40 V         |
| Operating voltage range           | $V_{CC}$   | 4 to 28 V    |
| Typ. on-state resistance (per Ch) | $R_{ON}$   | 4 m $\Omega$ |
| Current limitation (typ)          | $I_{LIMH}$ | 135 A        |
| Stand-by current (max)            | $I_{STBY}$ | 0.5 $\mu$ A  |

- AEC-Q100 qualified
- General
  - Single channel smart high-side driver with CurrentSense analog feedback
  - Very low standby current
  - Compatible with 3.0 V and 5 V CMOS outputs
- Diagnostic functions
  - Overload and short to ground (power limitation) indication
  - Thermal shutdown indication
  - OFF-state open-load detection
  - Output short to  $V_{CC}$  detection
  - Sense enable/ disable
- Protections
  - Undervoltage shutdown
  - Overvoltage clamp
  - Load current limitation



### Description

The device is a single channel high-side driver manufactured using ST proprietary VIPower<sup>®</sup> technology and housed in the Octapak package. The device is designed to drive 12 V automotive grounded loads through a 3 V and 5 V CMOS-compatible interface, providing protection and diagnostics.

The device integrates advanced protective functions such as load current limitation, overload active management by power limitation and overtemperature shutdown.

A sense enable pin allows OFF-state diagnosis to be disabled during the module low-power mode as well as external sense resistor sharing among similar devices.

**Table 1: Device summary**

| Package | Order codes   |
|---------|---------------|
|         | Tape and reel |
| Octapak | VN7004CHTR    |

## Contents

|          |  |           |
|----------|--|-----------|
| <b>1</b> | <b>Block diagram and pin description .....</b>           | <b>5</b>  |
| <b>2</b> | <b>Electrical specification.....</b>                     | <b>7</b>  |
| 2.1      | Absolute maximum ratings .....                           | 7         |
| 2.2      | Thermal data .....                                       | 8         |
| 2.3      | Electrical characteristics.....                          | 8         |
| 2.4      | Electrical characteristics curves .....                  | 15        |
| <b>3</b> | <b>Protections.....</b>                                  | <b>19</b> |
| 3.1      | Power limitation .....                                   | 19        |
| 3.2      | Thermal shutdown.....                                    | 19        |
| 3.3      | Current limitation .....                                 | 19        |
| 3.4      | Negative voltage clamp.....                              | 19        |
| <b>4</b> | <b>Application information .....</b>                     | <b>20</b> |
| 4.1      | Protection against reverse battery.....                  | 20        |
| 4.2      | Immunity against transient electrical disturbances ..... | 21        |
| 4.3      | MCU I/Os protection.....                                 | 21        |
| 4.4      | CS - analog current sense .....                          | 22        |
| 4.4.1    | Principle of CurrentSense signal generation .....        | 23        |
| 4.4.2    | Short to VCC and OFF-state open-load detection .....     | 25        |
| <b>5</b> | <b>Package and PCB thermal data .....</b>                | <b>27</b> |
| 5.1      | Octapak thermal data .....                               | 27        |
| <b>6</b> | <b>Package information .....</b>                         | <b>30</b> |
| 6.1      | Octapak package information.....                         | 30        |
| 6.2      | Octapak packing information.....                         | 31        |
| 6.3      | Octapak marking information .....                        | 33        |
| <b>7</b> | <b>Revision history .....</b>                            | <b>34</b> |

---

## List of tables

|  |    |
|--|----|
| Table 1: Device summary .....  | 1  |
| Table 2: Pin functions .....   | 5  |
| Table 3: Suggested connections for unused and not connected pins .....         | 6  |
| Table 4: Absolute maximum ratings .....  | 7  |
| Table 5: Thermal data .....  | 8  |
| Table 6: Power section .....   | 8  |
| Table 7: Switching .....   | 9  |
| Table 8: Logic inputs .....  | 10 |
| Table 9: Protection .....  | 10 |
| Table 10: CurrentSense .....   | 11 |
| Table 11: Truth table .....  | 15 |
| Table 12: ISO 7637-2 - electrical transient conduction along supply line ..... | 21 |
| Table 13: CurrentSense pin levels in off-state .....                           | 25 |
| Table 14: PCB properties .....   | 27 |
| Table 15: Thermal parameters .....   | 29 |
| Table 16: Octapak mechanical data .....  | 30 |
| Table 17: Reel dimensions .....  | 32 |
| Table 18: Document revision history .....                                      | 34 |

## List of figures

|  |    |
|--|----|
| Figure 1: Block diagram .....  | 5  |
| Figure 2: Configuration diagram (top view).....                              | 6  |
| Figure 3: Current and voltage conventions.....                               | 7  |
| Figure 4: IOOUT/ISENSE vs. IOOUT.....  | 13 |
| Figure 5: Current sense precision vs. IOOUT .....                            | 13 |
| Figure 6: Switching times and pulse skew .....                               | 14 |
| Figure 7: TDSTKON.....   | 14 |
| Figure 8: OFF-state output current .....                                     | 15 |
| Figure 9: Standby current .....  | 15 |
| Figure 10: IGND(ON) vs. Iout .....   | 16 |
| Figure 11: Logic input high level voltage .....                              | 16 |
| Figure 12: Logic input low level voltage.....                                | 16 |
| Figure 13: High level logic input current .....                              | 16 |
| Figure 14: Low level logic input current .....                               | 16 |
| Figure 15: Logic input hysteresis voltage .....                              | 16 |
| Figure 16: Undervoltage shutdown.....  | 17 |
| Figure 17: On-state resistance vs. Tcase .....                               | 17 |
| Figure 18: On-state resistance vs. VCC .....                                 | 17 |
| Figure 19: Turn-on voltage slope.....  | 17 |
| Figure 20: Turn-off voltage slope.....                                       | 17 |
| Figure 21: Won vs. Tcase.....  | 17 |
| Figure 22: Woff vs. Tcase.....   | 18 |
| Figure 23: ILIMH vs. Tcase.....  | 18 |
| Figure 24: Turn-off output voltage clamp.....                                | 18 |
| Figure 25: OFF-state open-load voltage detection threshold .....             | 18 |
| Figure 26: Vs clamp vs. Tcase .....  | 18 |
| Figure 27: Vsenseh vs. Tcase .....   | 18 |
| Figure 28: Application diagram .....   | 20 |
| Figure 29: Simplified internal structure .....                               | 20 |
| Figure 30: CurrentSense and diagnostic – block diagram.....                  | 22 |
| Figure 31: CurrentSense block diagram .....                                  | 23 |
| Figure 32: Analogue HSD – open-load detection in off-state .....             | 24 |
| Figure 33: Open-load / short to VCC condition.....                           | 25 |
| Figure 34: Maximum turn off current vs. inductance .....                     | 26 |
| Figure 35: Octapak on two-layers PCB (2s0p to JEDEC JESD 51-5).....          | 27 |
| Figure 36: Octapak on four-layers PCB (2s2p to JEDEC JESD 51-7) .....        | 27 |
| Figure 37: Rthj-amb vs PCB copper area in open box free air conditions ..... | 28 |
| Figure 38: Octapak thermal impedance junction ambient single pulse .....     | 28 |
| Figure 39: Thermal fitting model for Octapak .....                           | 29 |
| Figure 40: Octapak package dimensions .....                                  | 30 |
| Figure 41: Octapack reel 13" .....   | 31 |
| Figure 42: Octapak carrier tape .....  | 32 |
| Figure 43: Octapak schematic drawing of leader and trailer tape .....        | 33 |
| Figure 44: Octapak marking information.....                                  | 33 |



Figure 2: Configuration diagram (top view)

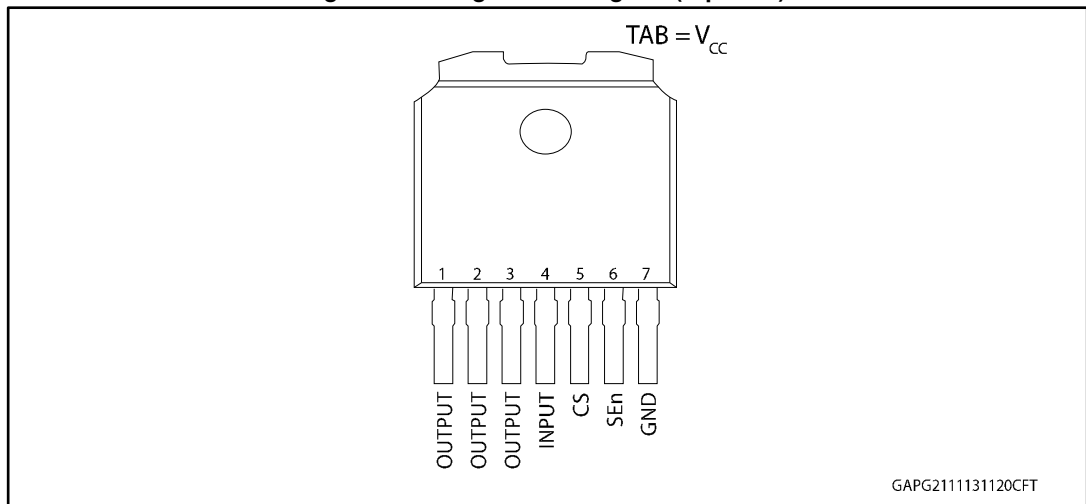

Table 3: Suggested connections for unused and not connected pins

| Connection / pin | CurrentSense          | N.C.             | Output      | Input                  | SEn                    |
|------------------|-----------------------|------------------|-------------|------------------------|------------------------|
| Floating         | Not allowed           | X <sup>(1)</sup> | X           | X                      | X                      |
| To ground        | Through 1 kΩ resistor | X                | Not allowed | Through 15 kΩ resistor | Through 15 kΩ resistor |

**Notes:**

<sup>(1)</sup>X: do not care.

## 2 Electrical specification

Figure 3: Current and voltage conventions

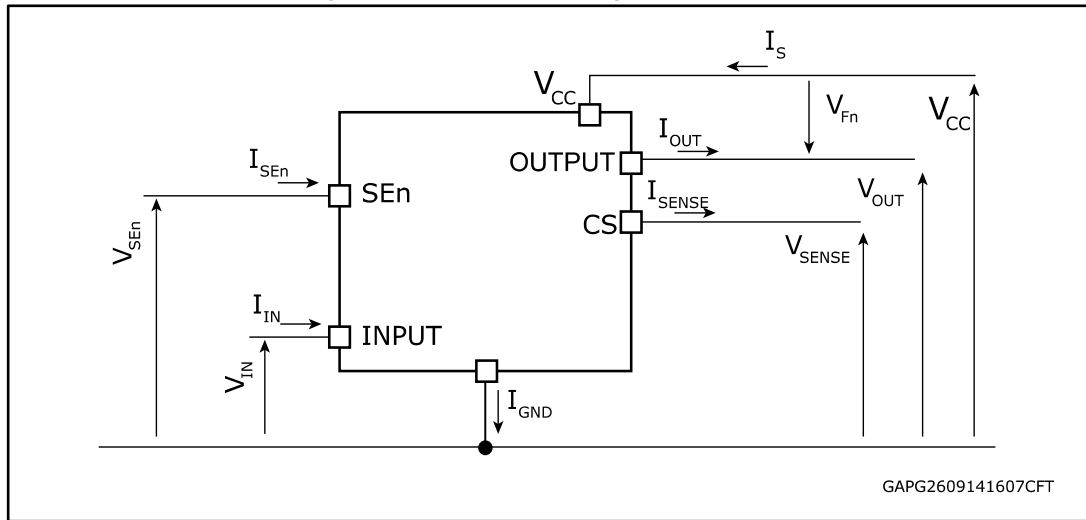

$V_F = V_{OUT} - V_{CC}$  when  $V_{OUT} > V_{CC}$  and INPUT = LOW

### 2.1 Absolute maximum ratings

Stressing the device above the rating listed in [Table 4: "Absolute maximum ratings"](#) may cause permanent damage to the device. These are stress ratings only and operation of the device at these or any other conditions above those indicated in the operating sections of this specification is not implied. Exposure to the conditions in the table below for extended periods may affect device reliability.

Table 4: Absolute maximum ratings

| Symbol      | Parameter   | Value              | Unit |
|-------------|---|--------------------|------|
| $V_{CC}$    | DC supply voltage   | 38                 | V    |
| $V_{CCPK}$  | Maximum transient supply voltage (ISO7637-2:2004 Pulse 5b level IV clamped to 40 V; $R_L = 4\Omega$ ) | 40                 |      |
| $-V_{CC}$   | Reverse DC supply voltage   | 16                 |      |
| $-I_{GND}$  | DC reverse ground pin current   | 200                | mA   |
| $I_{OUT}$   | OUTPUT DC output current  | Internally limited | A    |
| $-I_{OUT}$  | Reverse DC output current   | 38                 |      |
| $I_{IN}$    | INPUT DC input current  | -1 to 10           | mA   |
| $I_{SEn}$   | SEn DC input current  |                    |      |
| $I_{SENSE}$ | CS pin DC output current ( $V_{GND} = V_{CC}$ and $V_{SENSE} < 0$ V)                                  | 10                 | mA   |
|             | CS pin DC output current in reverse ( $V_{CC} < 0$ V)   | -20                |      |
| $E_{MAX}$   | Maximum switching energy (single pulse)<br>$T_{DEMAG} = 0.13$ ms; $T_{jstart} = 150^\circ\text{C}$    | 105                | mJ   |

| Symbol           | Parameter                                | Value      | Unit |
|------------------|--|------------|------|
| V <sub>ESD</sub> | Electrostatic discharge (JEDEC 22A-114F) | 4000       | V    |
|                  | • INPUT                                  | 2000       | V    |
|                  | • CurrentSense                           | 4000       | V    |
|                  | • SEn                                    | 4000       | V    |
|                  | • OUTPUT                                 | 4000       | V    |
|                  | • V <sub>CC</sub>                        | 4000       | V    |
| V <sub>ESD</sub> | Charge device model (CDM-AEC-Q100-011)   | 750        | V    |
| T <sub>j</sub>   | Junction operating temperature           | -40 to 150 | °C   |
| T <sub>stg</sub> | Storage temperature                      | -55 to 150 |      |

## 2.2 Thermal data

Table 5: Thermal data

| Symbol                | Parameter  | Typ. value | Unit |
|-----------------------|--|------------|------|
| R <sub>thj-case</sub> | Thermal resistance junction-case <sup>(1)</sup>                      | 1.45       | °C/W |
| R <sub>thj-amb</sub>  | Thermal resistance junction-ambient (JEDEC JESD 51-5) <sup>(2)</sup> | 58.1       |      |
| R <sub>thj-amb</sub>  | Thermal resistance junction-ambient (JEDEC JESD 51-7) <sup>(1)</sup> | 15.6       |      |

### Notes:

<sup>(1)</sup>Device mounted on four-layers 2s2p PCB

<sup>(2)</sup>Device mounted on two-layers 2s0p PCB with 2 cm<sup>2</sup> heatsink copper trace

## 2.3 Electrical characteristics

7 V < V<sub>CC</sub> < 28 V; -40°C < T<sub>j</sub> < 150°C, unless otherwise specified.

All typical values refer to V<sub>CC</sub> = 13 V; T<sub>j</sub> = 25 °C, unless otherwise specified.

Table 6: Power section

| Symbol                | Parameter  | Test conditions  | Min. | Typ. | Max. | Unit |
|-----------------------|--|--|------|------|------|------|
| V <sub>CC</sub>       | Operating supply voltage                         |  | 4    | 13   | 28   | V    |
| V <sub>USD</sub>      | Undervoltage shutdown                            |  |      |      | 4    |      |
| V <sub>USDReset</sub> | Undervoltage shutdown reset                      |  |      |      | 5    |      |
| V <sub>USDhyst</sub>  | Undervoltage shutdown hysteresis                 |  |      | 0.3  |      |      |
| R <sub>ON</sub>       | On-state resistance                              | I <sub>OUT</sub> = 15 A; T <sub>j</sub> = 25°C                           |      | 4    |      | mΩ   |
|                       |  | I <sub>OUT</sub> = 15 A; T <sub>j</sub> = 150°C                          |      |      | 8    |      |
|                       |  | I <sub>OUT</sub> = 15 A; V <sub>CC</sub> = 4 V; T <sub>j</sub> = 25°C    |      |      | 6    |      |
| R <sub>ON_Rev</sub>   | R <sub>DS(on)</sub> in reverse battery condition | V <sub>CC</sub> = -13 V; I <sub>OUT</sub> = -15 A; T <sub>j</sub> = 25°C |      | 4    |      | mΩ   |
| V <sub>clamp</sub>    | Clamp voltage                                    | I <sub>S</sub> = 20 mA; T <sub>j</sub> = -40°C                           | 38   |      |      | V    |
|                       |  | I <sub>S</sub> = 20 mA; 25°C < T <sub>j</sub> < 150°C                    | 41   | 46   | 52   |      |



| Symbol               | Parameter   | Test conditions   | Min. | Typ. | Max. | Unit |
|----------------------|---|---|------|------|------|------|
| I <sub>STBY</sub>    | Supply current in standby at V <sub>CC</sub> = 13 V <sup>(1)</sup>  | V <sub>CC</sub> = 13 V;<br>V <sub>IN</sub> = V <sub>OUT</sub> = V <sub>SEn</sub> = 0 V;<br>T <sub>j</sub> = 25°C                |      |      | 0.5  | μA   |
|                      |   | V <sub>CC</sub> = 13 V;<br>V <sub>IN</sub> = V <sub>OUT</sub> = V <sub>SEn</sub> = 0 V;<br>T <sub>j</sub> = 85°C <sup>(2)</sup> |      |      | 1.4  | μA   |
|                      |   | V <sub>CC</sub> = 13 V;<br>V <sub>IN</sub> = V <sub>OUT</sub> = V <sub>SEn</sub> = 0 V;<br>T <sub>j</sub> = 125°C               |      |      | 11   | μA   |
| t <sub>D_STBY</sub>  | Standby mode blanking time  | V <sub>CC</sub> = 13 V; V <sub>IN</sub> = 5 V;<br>V <sub>SEn</sub> = 0 V; I <sub>OUT</sub> = 0 A                                | 60   | 300  | 550  | μs   |
| I <sub>S(ON)</sub>   | Supply current  | V <sub>CC</sub> = 13 V; V <sub>SEn</sub> = 0 V;<br>V <sub>IN</sub> = 5 V; I <sub>OUT</sub> = 0 A                                |      | 4    | 6.5  | mA   |
| I <sub>GND(ON)</sub> | Control stage current consumption in ON-state. All channels active. | V <sub>CC</sub> = 13 V; V <sub>SEn</sub> = 5 V;<br>V <sub>IN</sub> = 5 V; I <sub>OUT</sub> = 15 A                               |      |      | 9    | mA   |
| I <sub>L(off)</sub>  | Off-state output current at V <sub>CC</sub> = 13 V                  | V <sub>IN</sub> = V <sub>OUT</sub> = 0 V; V <sub>CC</sub> = 13 V;<br>T <sub>j</sub> = 25°C                                      | 0    | 0.01 | 0.5  | μA   |
|                      |   | V <sub>IN</sub> = V <sub>OUT</sub> = 0 V; V <sub>CC</sub> = 13 V;<br>T <sub>j</sub> = 125°C                                     | 0    |      | 11   |      |
| V <sub>F</sub>       | Output - V <sub>CC</sub> diode voltage                              | I <sub>OUT</sub> = -15 A; T <sub>j</sub> = 150°C  |      |      | 0.7  | V    |

**Notes:**

(1)PowerMOS leakage included.

(2)Parameter specified by design; not subject to production test.

**Table 7: Switching**

| V <sub>CC</sub> = 13 V; -40 °C < T <sub>j</sub> < 150 °C, unless otherwise specified |  |                         |       |      |                    |      |
|--|--|-------------------------|-------|------|--------------------|------|
| Symbol   | Parameter  | Test conditions         | Min.  | Typ. | Max.               | Unit |
| t <sub>d(on)</sub> <sup>(1)</sup>  | Turn-on delay time at T <sub>j</sub> = 25 °C                   | R <sub>L</sub> = 0.87 Ω | 10    | 50   | 120                | μs   |
| t <sub>d(off)</sub> <sup>(1)</sup>   | Turn-off delay time at T <sub>j</sub> = 25 °C                  |                         | 10    | 60   | 100                |      |
| (dV <sub>OUT</sub> /dt) <sub>on</sub> <sup>(1)</sup>                                 | Turn-on voltage slope at T <sub>j</sub> = 25 °C                | R <sub>L</sub> = 0.87 Ω | 0.075 | 0.28 | 0.7                | V/μs |
| (dV <sub>OUT</sub> /dt) <sub>off</sub> <sup>(1)</sup>                                | Turn-off voltage slope at T <sub>j</sub> = 25 °C               |                         | 0.075 | 0.33 | 0.7                |      |
| W <sub>ON</sub>  | Switching energy losses at turn-on (t <sub>won</sub> )         | R <sub>L</sub> = 0.87 Ω | —     | 1.8  | 3.6 <sup>(2)</sup> | mJ   |
| W <sub>OFF</sub>   | Switching energy losses at turn-off (t <sub>woff</sub> )       | R <sub>L</sub> = 0.87 Ω | —     | 2    | 3.6 <sup>(2)</sup> | mJ   |
| t <sub>SKREW</sub> <sup>(1)</sup>  | Differential Pulse skew (t <sub>PHL</sub> - t <sub>PLH</sub> ) | R <sub>L</sub> = 0.87 Ω | -50   | 0    | 50                 | μs   |

**Notes:**(1)See [Figure 6: "Switching times and pulse skew"](#)

(2)Parameter guaranteed by design and characterization; not subject to production test.

Table 8: Logic inputs

| 7 V < V <sub>CC</sub> < 28 V; -40 °C < T <sub>j</sub> < 150 °C |                          |                         |      |      |      |      |
|--|--------------------------|-------------------------|------|------|------|------|
| Symbol   | Parameter                | Test conditions         | Min. | Typ. | Max. | Unit |
| <b>INPUT characteristics</b>                                   |                          |                         |      |      |      |      |
| V <sub>IL</sub>  | Input low level voltage  |                         |      |      | 0.9  | V    |
| I <sub>IL</sub>  | Low level input current  | V <sub>IN</sub> = 0.9 V | 1    |      |      | μA   |
| V <sub>IH</sub>  | Input high level voltage |                         | 2.1  |      |      | V    |
| I <sub>IH</sub>  | High level input current | V <sub>IN</sub> = 2.1 V |      |      | 10   | μA   |
| V <sub>I(hyst)</sub>   | Input hysteresis voltage |                         | 0.2  |      |      | V    |
| V <sub>ICL</sub>   | Input clamp voltage      | I <sub>IN</sub> = 1 mA  | 5.3  |      | 7.5  | V    |
|  |                          | I <sub>IN</sub> = -1 mA |      | -0.7 |      |      |
| <b>SEn characteristics (7 V &lt; V<sub>CC</sub> &lt; 18 V)</b> |                          |                         |      |      |      |      |
| V <sub>SEnL</sub>  | Input low level voltage  |                         |      |      | 0.9  | V    |
| I <sub>SEnL</sub>  | Low level input current  | V <sub>IN</sub> = 0.9 V | 1    |      |      | μA   |
| V <sub>SEnH</sub>  | Input high level voltage |                         | 2.1  |      |      | V    |
| I <sub>SEnH</sub>  | High level input current | V <sub>IN</sub> = 2.1 V |      |      | 10   | μA   |
| V <sub>SEn(hyst)</sub>   | Input hysteresis voltage |                         | 0.2  |      |      | V    |
| V <sub>SEnCL</sub>   | Input clamp voltage      | I <sub>IN</sub> = 1 mA  | 5.3  |      | 7.5  | V    |
|  |                          | I <sub>IN</sub> = -1 mA |      | -0.7 |      |      |

Table 9: Protection

| 7 V < V <sub>CC</sub> < 18 V; -40 °C < T <sub>j</sub> < 150 °C |  |   |                      |                      |                      |      |
|--|--|---|----------------------|----------------------|----------------------|------|
| Symbol   | Parameter  | Test conditions   | Min.                 | Typ.                 | Max.                 | Unit |
| I <sub>LIMH</sub> <sup>(1)</sup>                               | DC short circuit current   | V <sub>CC</sub> = 13 V  | 80                   | 135                  | 175                  | A    |
|  |  | 4 V < V <sub>CC</sub> < 18 V <sup>(2)</sup>                                   |                      |                      | 175                  |      |
| I <sub>LIML</sub>  | Short circuit current during thermal cycling                           | V <sub>CC</sub> = 13 V;<br>T <sub>R</sub> < T <sub>j</sub> < T <sub>TSD</sub> |                      | 38                   |                      |      |
| T <sub>TSD</sub>   | Shutdown temperature   |   | 150                  | 175                  | 200                  | °C   |
| T <sub>R</sub>   | Reset temperature <sup>(2)</sup>                                       |   | T <sub>RS</sub> + 1  | T <sub>RS</sub> + 7  |                      |      |
| T <sub>RS</sub>  | Thermal reset of fault diagnostic indication                           | V <sub>SEn</sub> = 5 V  | 135                  |                      |                      |      |
| T <sub>HYST</sub>  | Thermal hysteresis (T <sub>TSD</sub> - T <sub>R</sub> ) <sup>(2)</sup> |   |                      | 7                    |                      |      |
| ΔT <sub>J_SD</sub>   | Dynamic temperature  | V <sub>CC</sub> = 13 V  |                      | 60                   |                      | K    |
| V <sub>DEMAG</sub>   | Turn-off output voltage clamp  | I <sub>OUT</sub> = 2 A; L = 6 mH;<br>T <sub>j</sub> = -40°C                   | V <sub>CC</sub> - 38 |                      |                      | V    |
|  |  | I <sub>OUT</sub> = 2 A; L = 6 mH;<br>T <sub>j</sub> = 25°C to 150°C           | V <sub>CC</sub> - 41 | V <sub>CC</sub> - 46 | V <sub>CC</sub> - 52 | V    |

**Notes:**

<sup>(1)</sup>Parameter guaranteed by an indirect test sequence.

<sup>(2)</sup>Parameter guaranteed by design and characterization; not subject to production test.

Table 10: CurrentSense

| 7 V < V <sub>CC</sub> < 18 V; -40 °C < T <sub>j</sub> < 150 °C |   |   |       |       |       |      |
|--|---|---|-------|-------|-------|------|
| Symbol   | Parameter   | Test conditions   | Min.  | Typ.  | Max.  | Unit |
| V <sub>SENSE_CL</sub>  | CurrentSense clamp voltage  | V <sub>SEN</sub> = 0 V; I <sub>SENSE</sub> = 1 mA   | -17   |       | -12   | V    |
|  |   | V <sub>SEN</sub> = 0 V; I <sub>SENSE</sub> = -1 mA  |       | 7     |       | V    |
| <b>Current Sense characteristics</b>                           |   |   |       |       |       |      |
| K <sub>1</sub>   | I <sub>OUT</sub> /I <sub>SENSE</sub>  | I <sub>OUT</sub> = 10 A; V <sub>SENSE</sub> = 4 V;<br>V <sub>SEN</sub> = 5 V  | 10040 | 16720 | 23400 |      |
| dK <sub>1</sub> /K <sub>1</sub> <sup>(1)(2)</sup>              | Current sense ratio drift   | I <sub>OUT</sub> = 10 A; V <sub>SENSE</sub> = 4 V;<br>V <sub>SEN</sub> = 5 V  | -20   |       | 20    | %    |
| K <sub>2</sub>   | I <sub>OUT</sub> /I <sub>SENSE</sub>  | I <sub>OUT</sub> = 15 A; V <sub>SENSE</sub> = 4 V;<br>V <sub>SEN</sub> = 5 V  | 12530 | 16710 | 20890 |      |
| dK <sub>2</sub> /K <sub>2</sub> <sup>(1)(2)</sup>              | Current sense ratio drift   | I <sub>OUT</sub> = 15 A; V <sub>SENSE</sub> = 4 V;<br>V <sub>SEN</sub> = 5 V  | -15   |       | 15    | %    |
| K <sub>3</sub>   | I <sub>OUT</sub> /I <sub>SENSE</sub>  | I <sub>OUT</sub> = 45 A; V <sub>SENSE</sub> = 4 V;<br>V <sub>SEN</sub> = 5 V  | 14450 | 16970 | 18850 |      |
| dK <sub>3</sub> /K <sub>3</sub> <sup>(1)(2)</sup>              | Current sense ratio drift   | I <sub>OUT</sub> = 45 A; V <sub>SENSE</sub> = 4 V;<br>V <sub>SEN</sub> = 5 V  | -10   |       | 10    | %    |
| I <sub>SENSE0</sub>  | CurrentSense leakage current  | CurrentSense disabled:<br>V <sub>SEN</sub> = 0 V;   | 0     |       | 0.5   | μA   |
|  |   | CurrentSense disabled;<br>-1 V < V <sub>SENSE</sub> < 5 V <sup>(2)</sup>  | -0.5  |       | 0.5   | μA   |
|  |   | CurrentSense enabled:<br>V <sub>SEN</sub> = 5 V; V <sub>IN</sub> = 5 V;<br>I <sub>OUT</sub> = 0 A;  | 0     |       | 100   | μA   |
| V <sub>OUT_CSD</sub> <sup>(2)</sup>                            | Output voltage for CurrentSense shutdown  | V <sub>SEN</sub> = 5 V;<br>R <sub>SENSE</sub> = 2.7 kΩ; V <sub>IN</sub> = 5 V;<br>I <sub>OUT</sub> = 15 A   |       | 5     |       | V    |
| V <sub>SENSE_SAT</sub>   | CurrentSense saturation voltage   | V <sub>CC</sub> = 7 V; R <sub>SENSE</sub> = 10 kΩ;<br>V <sub>SEN</sub> = 5 V; V <sub>IN</sub> = 5 V;<br>I <sub>OUT</sub> = 15 A; T <sub>j</sub> = -40°C | 5     |       |       | V    |
| I <sub>SENSE_SAT</sub> <sup>(2)</sup>                          | CS saturation current   | V <sub>CC</sub> = 7 V; V <sub>SENSE</sub> = 4 V;<br>V <sub>IN</sub> = 5 V; V <sub>SEN</sub> = 5 V;<br>T <sub>j</sub> = -40°C                            | 4     |       |       | mA   |
| I <sub>OUT_SAT</sub> <sup>(2)</sup>                            | Output saturation current   | V <sub>CC</sub> = 7 V; V <sub>SENSE</sub> = 4 V;<br>V <sub>IN</sub> = 5 V; V <sub>SEN</sub> = 5 V;<br>T <sub>j</sub> = -40°C                            | 75    |       |       | A    |
| <b>OFF-state diagnostic</b>                                    |   |   |       |       |       |      |
| V <sub>OL</sub>  | OFF-state open-load voltage detection threshold   | V <sub>IN</sub> = 0 V; V <sub>SEN</sub> = 5 V;  | 2     | 3     | 4     | V    |
| I <sub>L(off2)</sub>   | OFF-state output sink current   | V <sub>IN</sub> = 0 V; V <sub>OUT</sub> = V <sub>OL</sub> ;<br>T <sub>j</sub> = -40°C to 125°C  | -100  |       | -15   | μA   |
| t <sub>DSTKON</sub>  | OFF-state diagnostic delay time from falling edge of INPUT (see <a href="#">Figure 7: "TDSTKON"</a> ) | V <sub>IN</sub> = 5 V to 0 V;<br>V <sub>SEN</sub> = 5 V; I <sub>OUT</sub> = 0 A;<br>V <sub>OUT</sub> = 4 V  | 100   | 350   | 700   | μs   |

| 7 V < V <sub>CC</sub> < 18 V; -40 °C < T <sub>j</sub> < 150 °C |   |   |      |      |      |      |
|--|---|---|------|------|------|------|
| Symbol   | Parameter   | Test conditions   | Min. | Typ. | Max. | Unit |
| t <sub>D_OL_V</sub>  | Settling time for valid OFF-state open load diagnostic indication from rising edge of SEn                                 | V <sub>IN</sub> = 0 V; V <sub>OUT</sub> = 4 V; V <sub>SEn</sub> = 0 V to 5 V  |      |      | 60   | μs   |
| t <sub>D_VOL</sub>   | OFF-state diagnostic delay time from rising edge of V <sub>OUT</sub>  | V <sub>IN</sub> = 0 V; V <sub>SEn</sub> = 5 V; V <sub>OUT</sub> = 0 V to 4 V  |      | 5    | 30   | μs   |
| <b>Fault diagnostic feedback (see Table 11: "Truth table")</b> |   |   |      |      |      |      |
| V <sub>SENSEH</sub>  | CurrentSense output voltage in fault condition  | V <sub>CC</sub> = 13 V; V <sub>IN</sub> = 0 V; V <sub>SEn</sub> = 5 V; I <sub>OUT</sub> = 0 A; V <sub>OUT</sub> = 4 V; R <sub>SENSE</sub> = 1 kΩ      | 5    |      | 6.6  | V    |
| I <sub>SENSEH</sub>  | CurrentSense output current in fault condition  | V <sub>CC</sub> = 13 V; V <sub>SENSE</sub> = 5 V  | 7    | 20   | 30   | mA   |
| <b>CurrentSense timings (current sense mode)<sup>(3)</sup></b> |   |   |      |      |      |      |
| t <sub>DSENSE1H</sub>  | Current sense settling time from rising edge of SEn   | V <sub>IN</sub> = 5 V; V <sub>SEn</sub> = 0 V to 5 V; R <sub>SENSE</sub> = 1 kΩ; R <sub>L</sub> = 0.87 Ω  |      |      | 60   | μs   |
| t <sub>DSENSE1L</sub>  | Current sense disable delay time from falling edge of SEn   | V <sub>IN</sub> = 5 V; V <sub>SEn</sub> = 5 V to 0 V; R <sub>SENSE</sub> = 1 kΩ; R <sub>L</sub> = 0.87 Ω  |      | 5    | 20   | μs   |
| t <sub>DSENSE2H</sub>  | Current sense settling time from rising edge of INPUT   | V <sub>IN</sub> = 0 V to 5 V; V <sub>SEn</sub> = 5 V; R <sub>SENSE</sub> = 1 kΩ; R <sub>L</sub> = 0.87 Ω  |      | 100  | 380  | μs   |
| Δt <sub>DSENSE2H</sub>   | Current sense settling time from rising edge of I <sub>OUT</sub> (dynamic response to a step change of I <sub>OUT</sub> ) | V <sub>IN</sub> = 5 V; V <sub>SEn</sub> = 5 V; R <sub>SENSE</sub> = 1 kΩ; I <sub>SENSE</sub> = 90% of I <sub>SENSEMAX</sub> ; R <sub>L</sub> = 0.87 Ω |      |      | 200  | μs   |
| t <sub>DSENSE2L</sub>  | Current sense turn-off delay time from falling edge of INPUT  | V <sub>IN</sub> = 5 V to 0 V; V <sub>SEn</sub> = 5 V; R <sub>SENSE</sub> = 1 kΩ; R <sub>L</sub> = 0.87 Ω  |      | 50   | 250  | μs   |

**Notes:**

- (1) All values refer to V<sub>CC</sub> = 13 V; T<sub>j</sub> = 25°C, unless otherwise specified.
- (2) Parameter guaranteed by design and characterization; not subject to production test.
- (3) Transition delay are measured up to ±10% of final conditions.

Figure 4: IOUT/ISENSE vs. IOUT

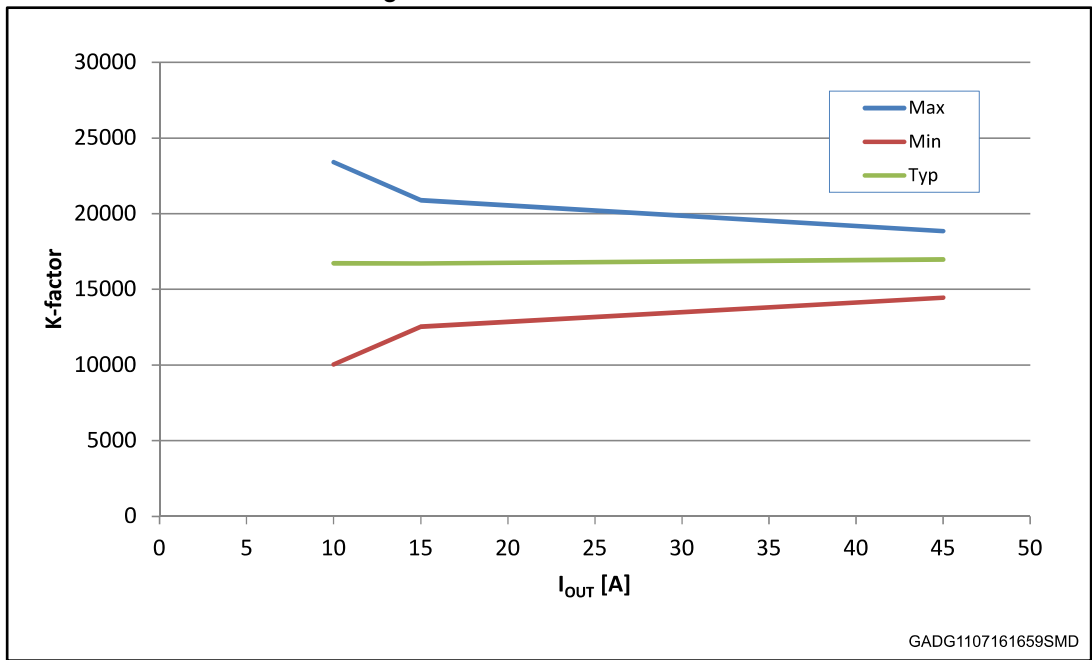

Figure 5: Current sense precision vs. IOUT

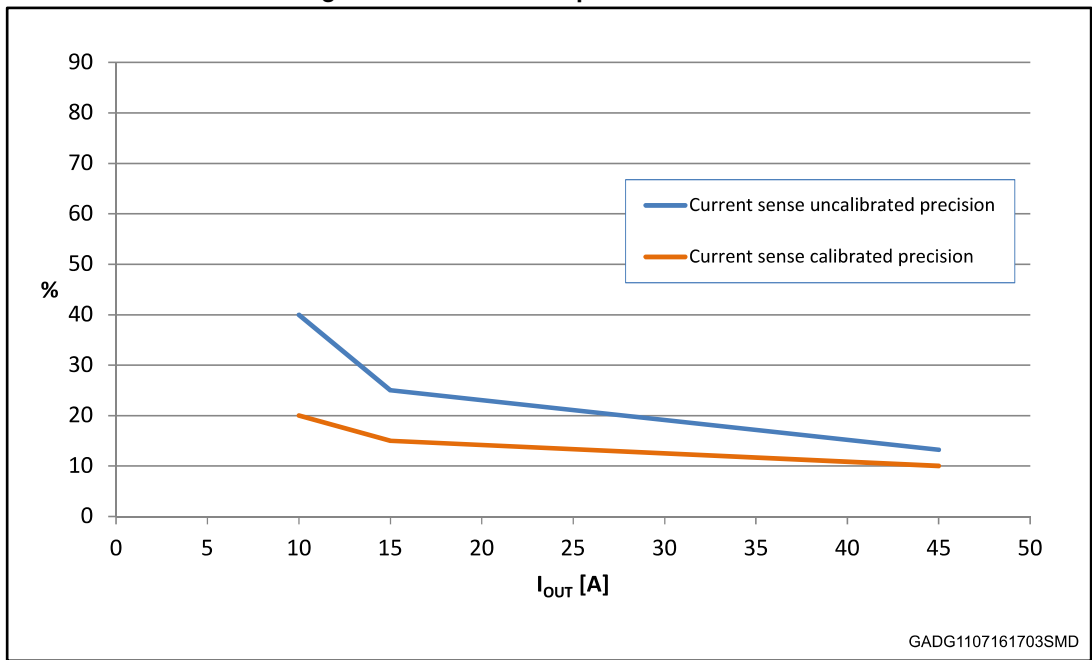

Figure 6: Switching times and pulse skew

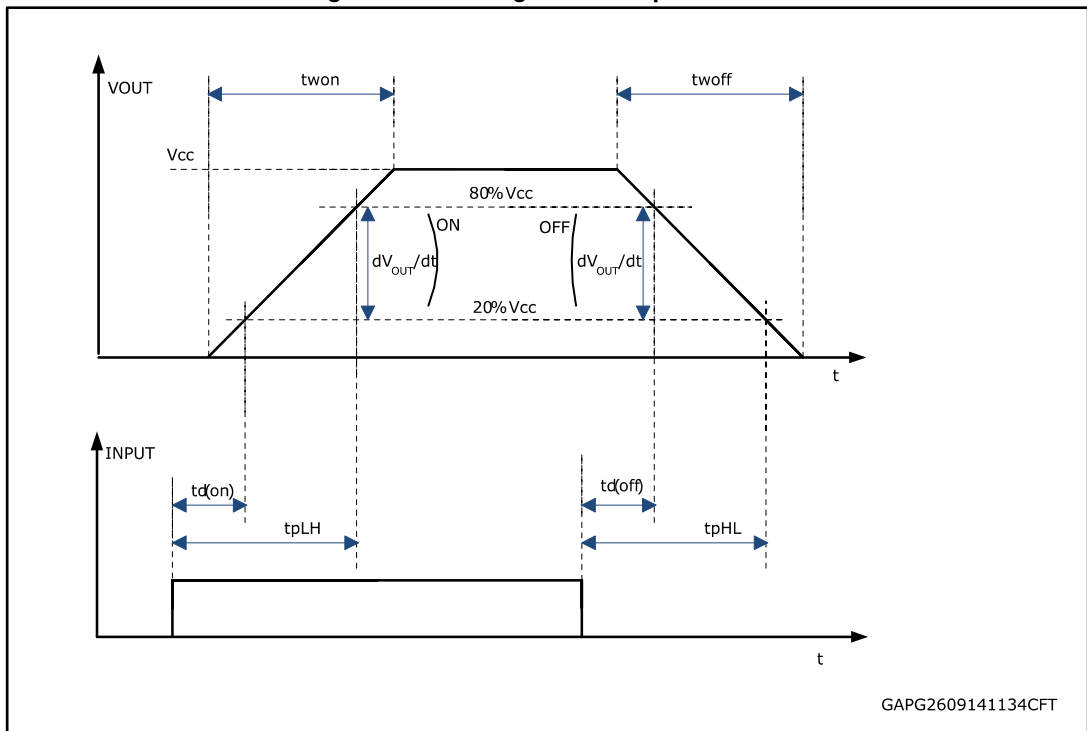

Figure 7: TDSTKON

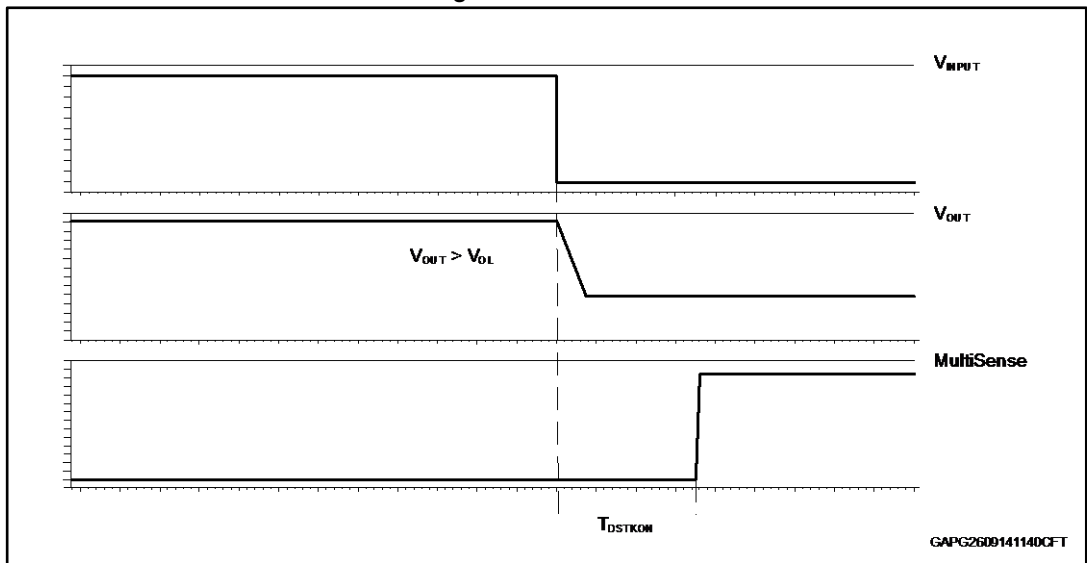
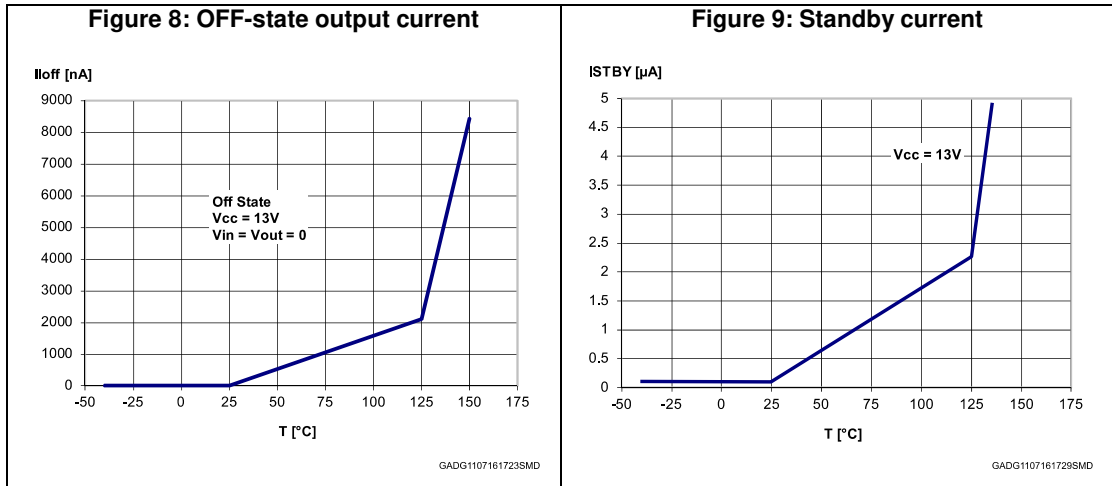

Table 11: Truth table

| Mode                    | Conditions  | IN <sub>x</sub> | SEn | OUT <sub>x</sub> | Current Sense                               | Comments   |
|-------------------------|---|-----------------|-----|------------------|---|--|
| Stand by                | All logic inputs low  | L               | L   | L                | Hi-Z  | Low quiescent current consumption  |
| Normal                  | Nominal load connected;<br>T <sub>j</sub> < 150°C   | L               | H   | L                | 0   |  |
|                         |   | H               | L   | H                | Hi-Z  |  |
|                         |   | H               | H   | H                | I <sub>SENSE</sub> = 1/K * I <sub>OUT</sub> |  |
| Overload                | Overload or short to GND causing:<br>T <sub>j</sub> > T <sub>TSD</sub> or<br>ΔT <sub>j</sub> > ΔT <sub>j_SD</sub> | H               | L   | H                | Hi-Z  | Output cycles with temperature hysteresis  |
|                         |   | H               | H   | H                | V <sub>SENSEH</sub>                         |  |
| Under-voltage           | V <sub>CC</sub> < V <sub>USD</sub> (falling)  | X               | X   | L<br>L           | Hi-Z<br>Hi-Z                                | Re-start when V <sub>CC</sub> > V <sub>USD</sub> + V <sub>USDhyst</sub> (rising) |
| OFF-state diagnostics   | Short to V <sub>CC</sub>  | L               | H   | H                | V <sub>SENSEH</sub>                         |  |
|                         | Open-load   | L               | H   | H                |   | External pull-up   |
| Negative output voltage | Inductive loads turn-off  | L               | X   | < 0 V            | 0   |  |

## 2.4 Electrical characteristics curves



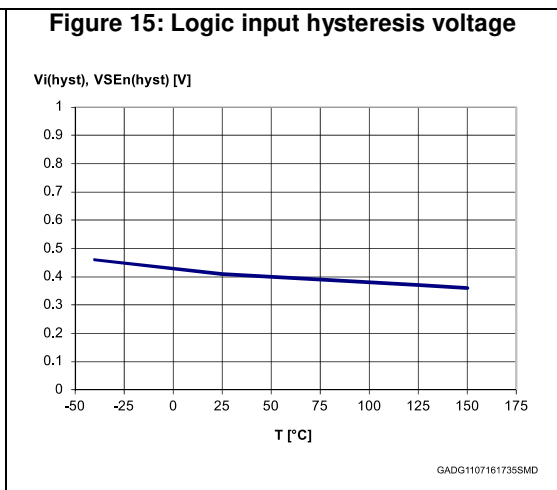
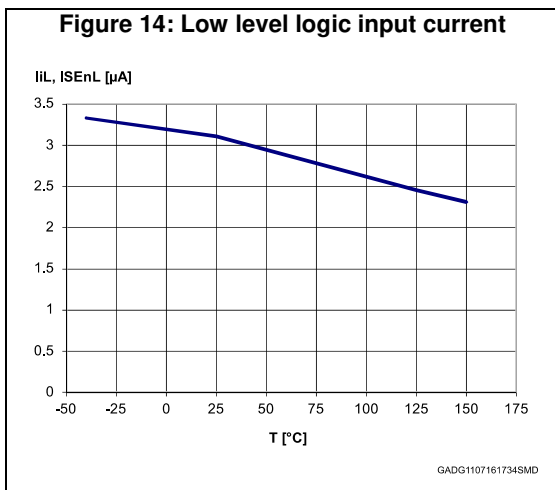
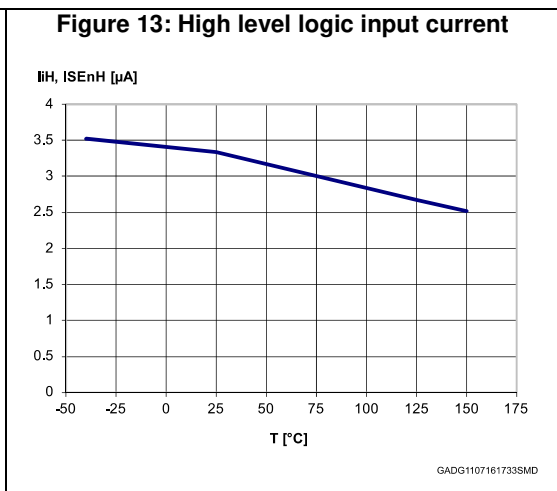
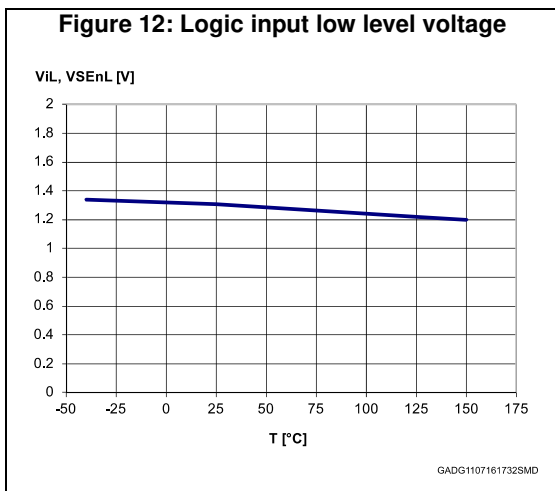
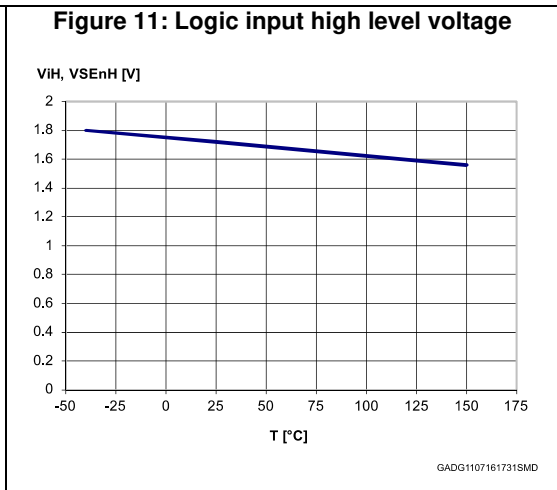
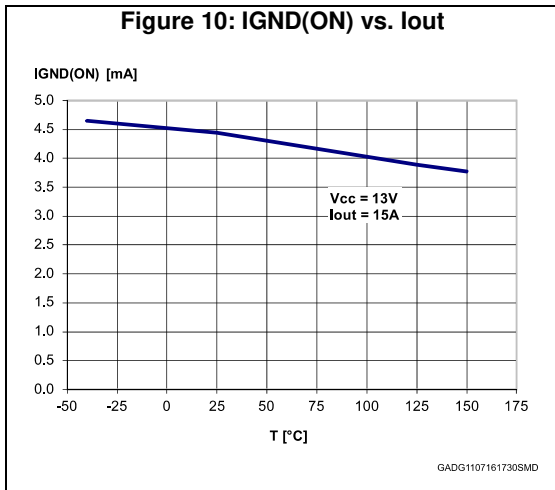
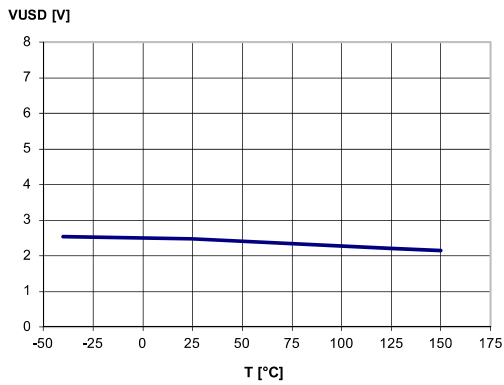

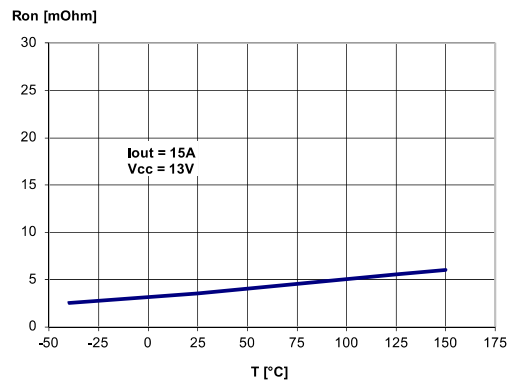

Figure 16: Undervoltage shutdown



GADG1107161736SMD

Figure 17: On-state resistance vs. Tcase



GADG1107161737SMD

Figure 18: On-state resistance vs. VCC

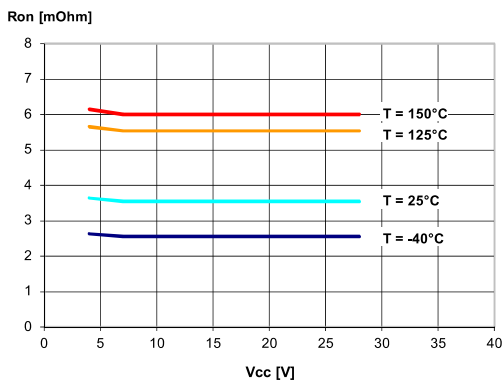

GADG1107161738SMD

Figure 19: Turn-on voltage slope

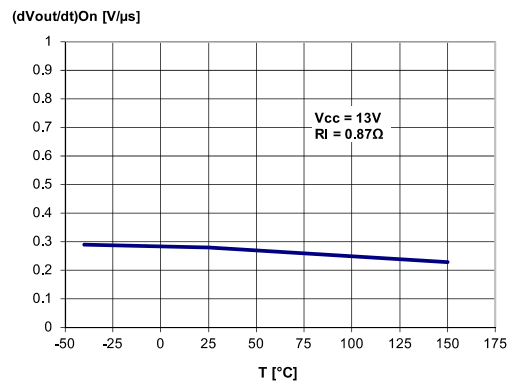

GADG1107161739SMD

Figure 20: Turn-off voltage slope

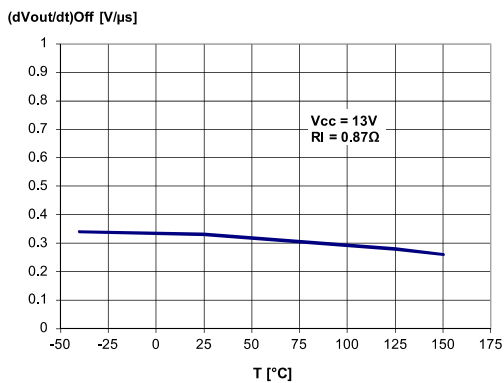

GADG1107161740SMD

Figure 21: Won vs. Tcase

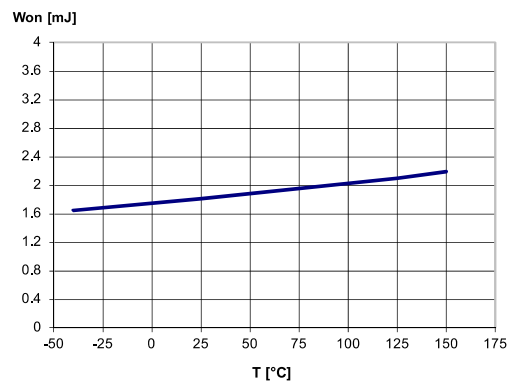

GADG1107161741SMD

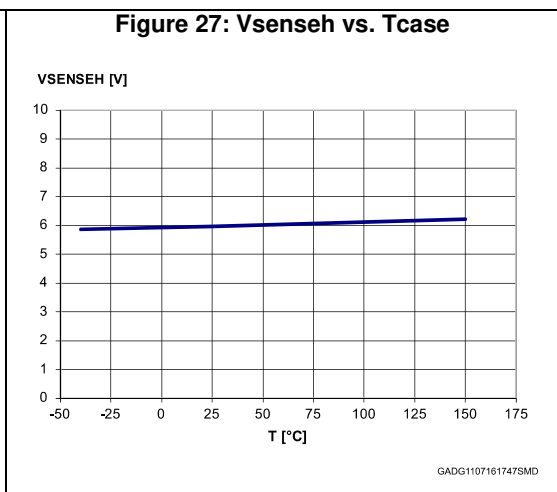
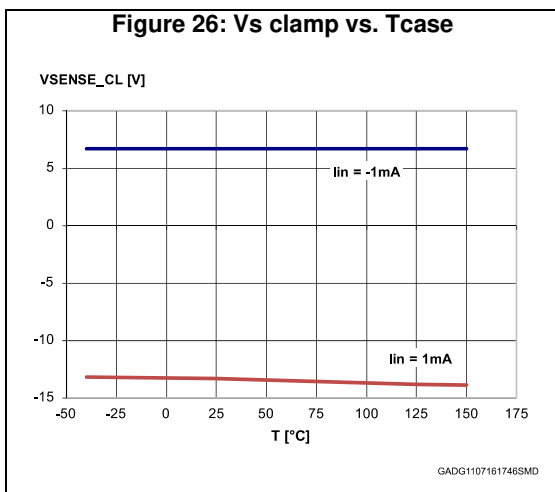
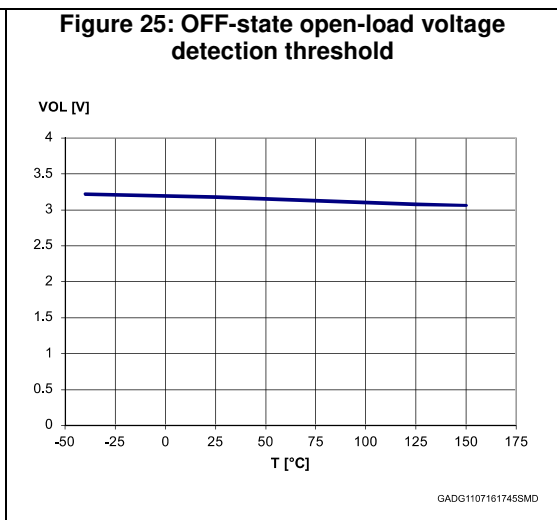
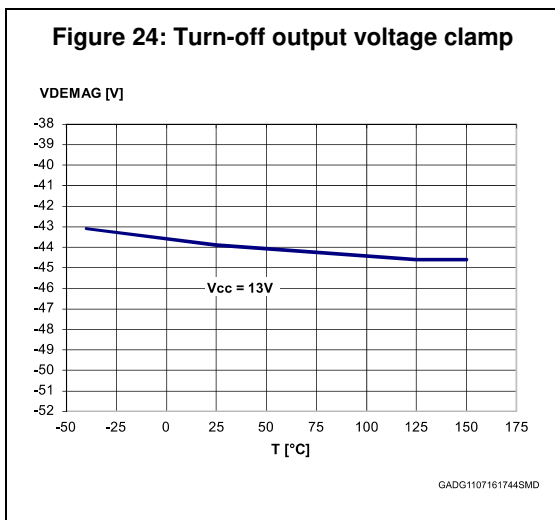
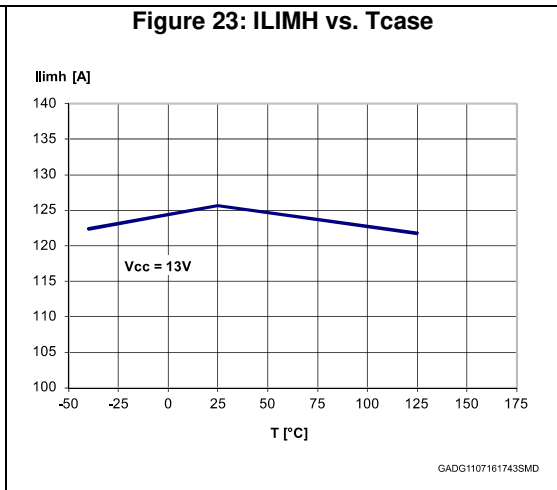
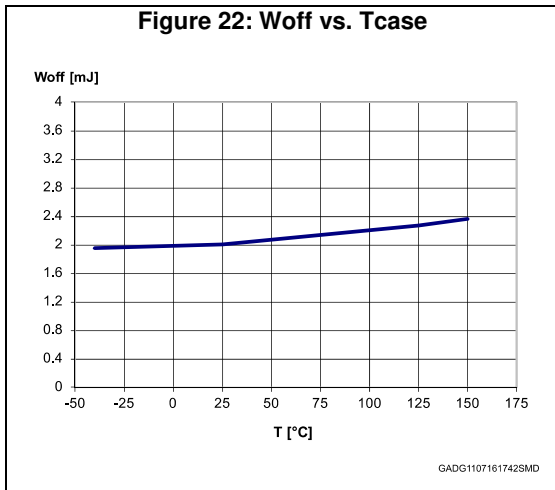

## 3 Protections

### 3.1 Power limitation

The basic working principle of this protection consists of an indirect measurement of the junction temperature swing  $\Delta T_j$  through the direct measurement of the spatial temperature gradient on the device surface in order to automatically shut off the output MOSFET as soon as  $\Delta T_j$  exceeds the safety level of  $\Delta T_{j\_SD}$ . The protection prevents fast thermal transient effects and, consequently, reduces thermo-mechanical fatigue.

### 3.2 Thermal shutdown

In case the junction temperature of the device exceeds the maximum allowed threshold (typically 175°C), it automatically switches off and the diagnostic indication is triggered. The device switches on again as soon as its junction temperature drops to  $T_R$ .

### 3.3 Current limitation

The device is equipped with an output current limiter in order to protect the silicon as well as the other components of the system (e.g. bonding wires, wiring harness, connectors, loads, etc.) from excessive current flow. Consequently, in case of short circuit, overload or during load power-up, the output current is clamped to a safety level,  $I_{LIMH}$ , by operating the output power MOSFET in the active region.

### 3.4 Negative voltage clamp

In case the device drives inductive load, the output voltage reaches negative value during turn off. A negative voltage clamp structure limits the maximum negative voltage to a certain value,  $V_{DEMAG}$ , allowing the inductor energy to be dissipated without damaging the device.

# 4 Application information

Figure 28: Application diagram

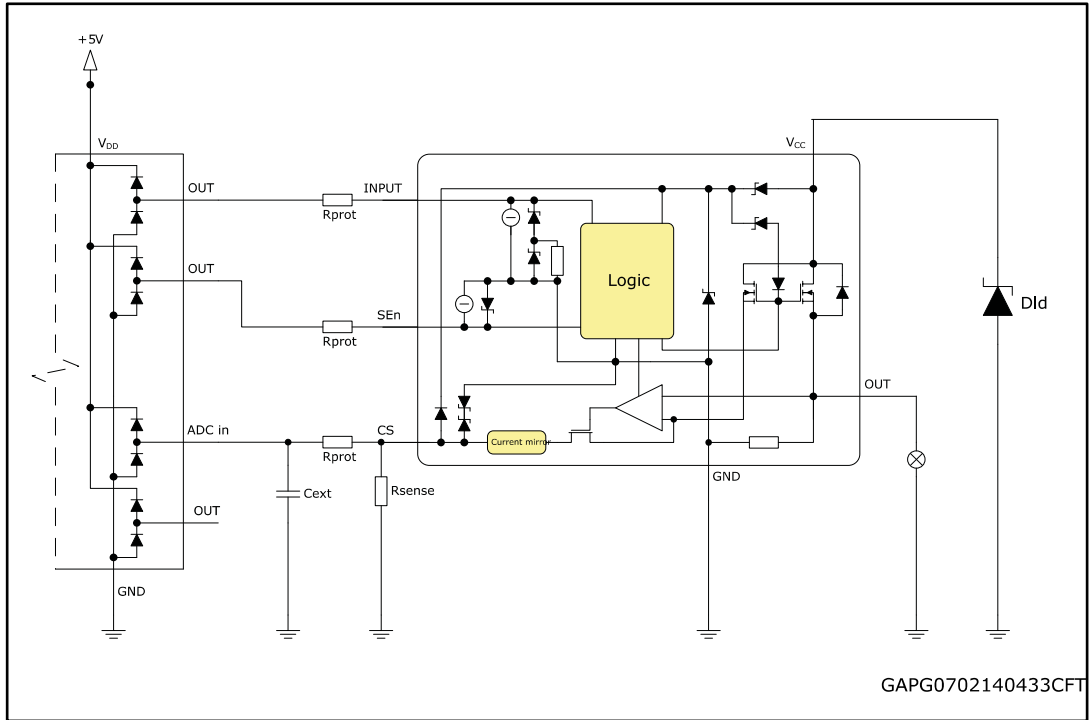

## 4.1 Protection against reverse battery

Figure 29: Simplified internal structure

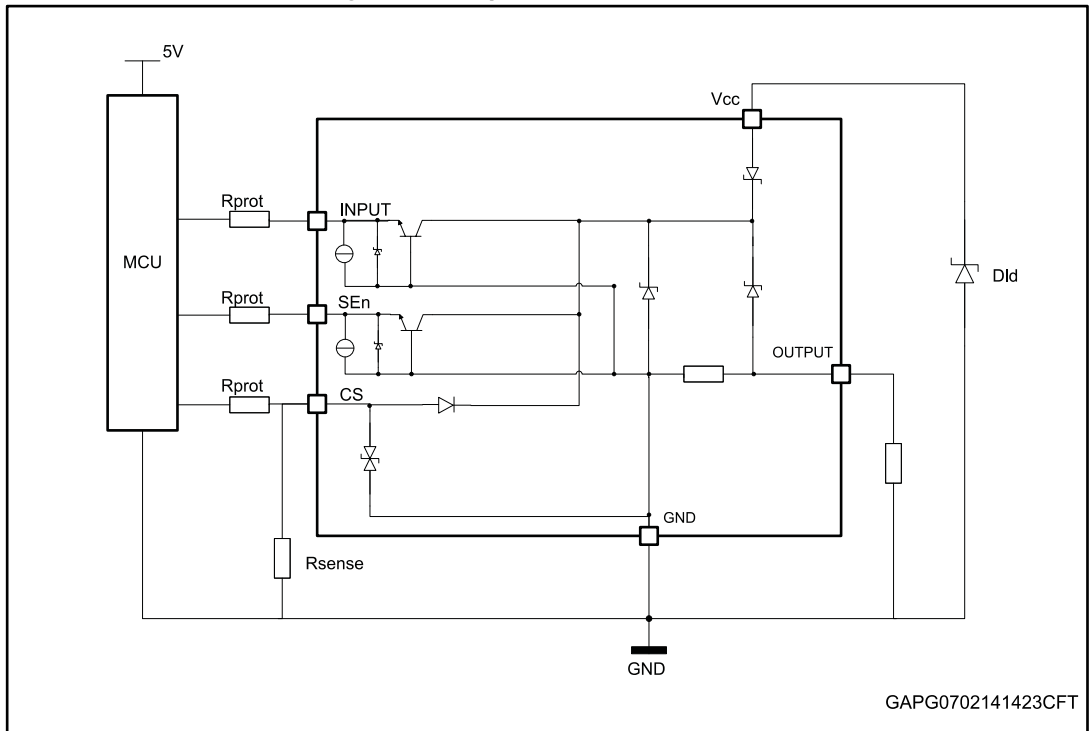

The device does not need any external components to protect the internal logic in case of a reverse battery condition. The protection is provided by internal structures.

In addition, due to the fact that the output MOSFET turns on even in reverse battery mode, thus providing the same low ohmic path as in regular operating conditions, no additional power dissipation has to be considered.

## 4.2 Immunity against transient electrical disturbances

The immunity of the device against transient electrical emissions, conducted along the supply lines and injected into the  $V_{CC}$  pin, is tested in accordance with ISO7637-2:2011 (E) and ISO 16750-2:2010.

The related function performance status classification is shown in [Table 12: "ISO 7637-2 - electrical transient conduction along supply line"](#).

Test pulses are applied directly to DUT (Device Under Test) both in ON and OFF-state and in accordance to ISO 7637-2:2011(E), chapter 4. The DUT is intended as the present device only, without components and accessed through  $V_{CC}$  and GND terminals.

Status II is defined in ISO 7637-1 Function Performance Status Classification (FPSC) as follows: "The function does not perform as designed during the test but returns automatically to normal operation after the test".

**Table 12: ISO 7637-2 - electrical transient conduction along supply line**

| Test Pulse 2011(E)                             | Test pulse severity level with Status II functional performance status |             | Minimum number of pulses or test time | Burst cycle / pulse repetition time |        | Pulse duration and pulse generator internal impedance |
|--|--|-------------|---------------------------------------|-------------------------------------|--------|---|
|  | Level  | $U_s^{(1)}$ |                                       | min                                 | max    |   |
| 1  | III  | -112V       | 500 pulses                            | 0,5 s                               |        | 2ms, 10 $\Omega$                                      |
| 2a   | III  | +55V        | 500 pulses                            | 0,2 s                               | 5 s    | 50 $\mu$ s, 2 $\Omega$                                |
| 3a   | IV   | -220V       | 1h                                    | 90 ms                               | 100 ms | 0.1 $\mu$ s, 50 $\Omega$                              |
| 3b   | IV   | +150V       | 1h                                    | 90 ms                               | 100 ms | 0.1 $\mu$ s, 50 $\Omega$                              |
| 4 <sup>(2)</sup>                               | IV   | -7V         | 1 pulse                               |                                     |        | 100ms, 0.01 $\Omega$                                  |
| <b>Load dump according to ISO 16750-2:2010</b> |  |             |                                       |                                     |        |   |
| Test B <sup>(3)</sup>                          |  | 40V         | 5 pulse                               | 1 min                               |        | 400ms, 2 $\Omega$                                     |

**Notes:**

<sup>(1)</sup> $U_s$  is the peak amplitude as defined for each test pulse in ISO 7637-2:2011(E), chapter 5.6.

<sup>(2)</sup>Test pulse from ISO 7637-2:2004(E).

<sup>(3)</sup>With 40 V external suppressor referred to ground ( $-40^{\circ}\text{C} < T_j < 150^{\circ}\text{C}$ ).

## 4.3 MCU I/Os protection

If a ground protection network is used and negative transients are present on the  $V_{CC}$  line, the control pins will be pulled negative. ST suggests to insert a resistor ( $R_{prot}$ ) in line both to prevent the microcontroller I/O pins from latch-up and to protect the HSD inputs.

The value of these resistors is a compromise between the leakage current of microcontroller and the current required by the HSD I/Os (Input levels compatibility) with the latch-up limit of microcontroller I/Os.

**Equation**

$$V_{CCpeak}/I_{latchup} \leq R_{prot} \leq (V_{OH\mu C}-V_{IH}-V_{GND}) / I_{IHmax}$$

Calculation example:

For  $V_{CCpeak} = -150\text{ V}$ ;  $I_{latchup} \geq 20\text{ mA}$ ;  $V_{OH\mu C} \geq 4.5\text{ V}$

$7.5\text{ k}\Omega \leq R_{prot} \leq 140\text{ k}\Omega$ .

Recommended values:  $R_{prot} = 15\text{ k}\Omega$

### 4.4 CS - analog current sense

Diagnostic information on device and load status are provided by an analog output pin (CS) delivering the following signal:

- Current monitor: current monitor of channel output current

**Figure 30: CurrentSense and diagnostic – block diagram**

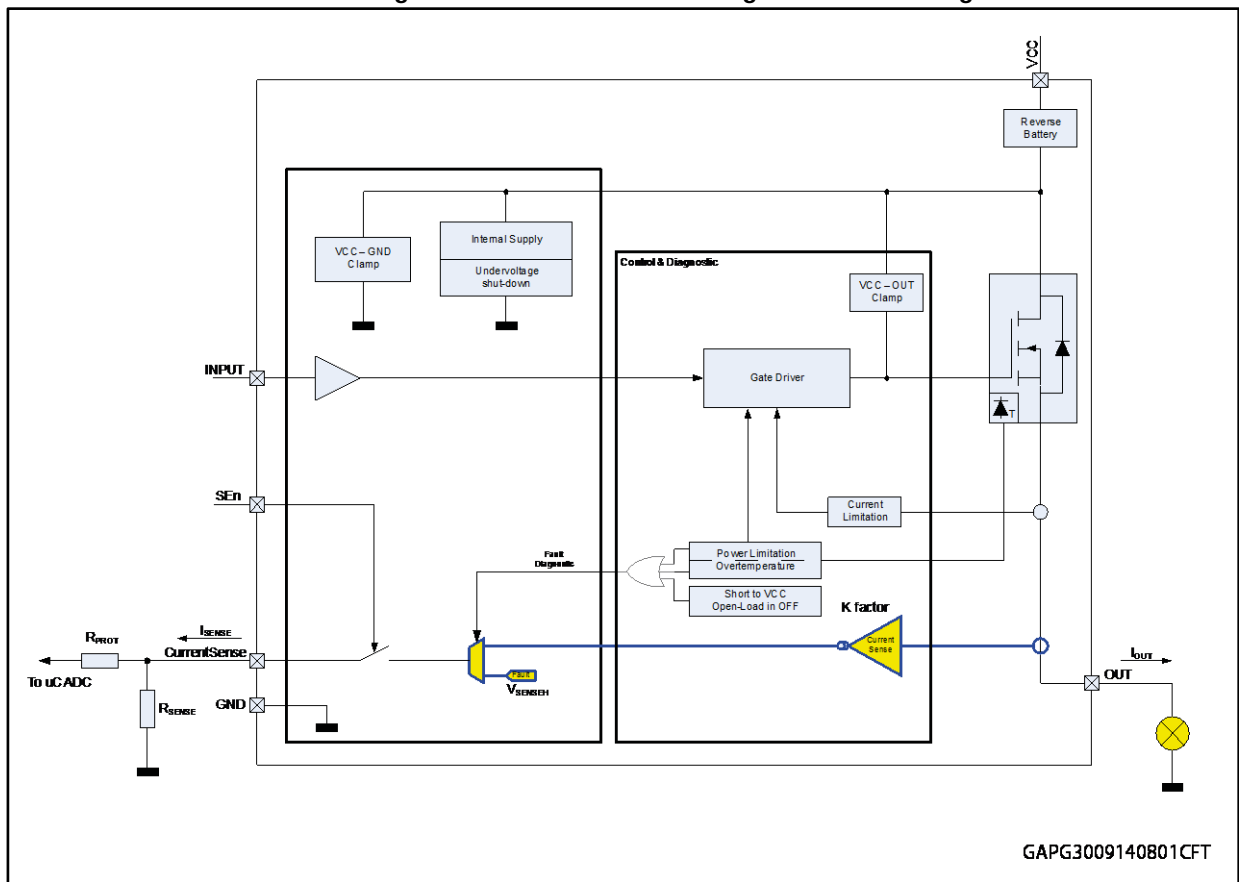

4.4.1 Principle of CurrentSense signal generation

Figure 31: CurrentSense block diagram

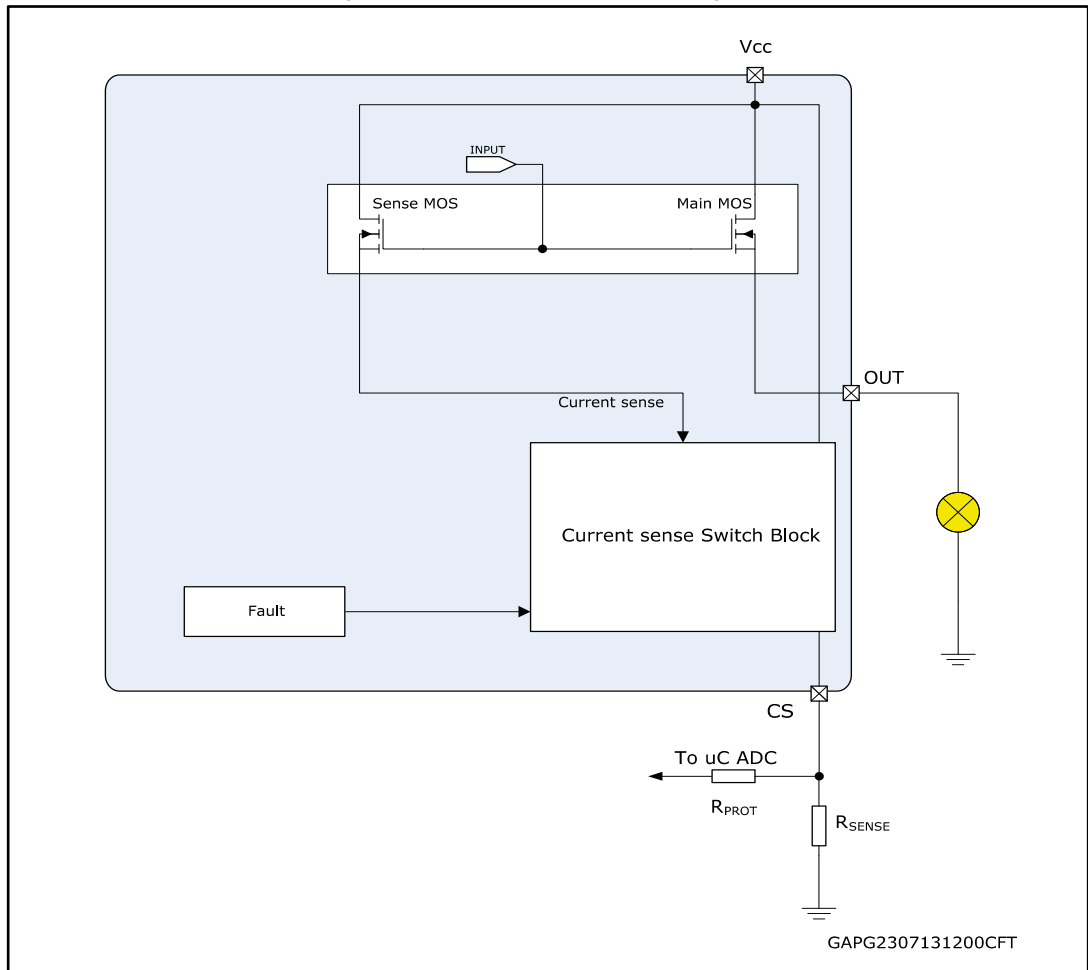

**Current sense**

This output is capable of providing:

- Current mirror proportional to the load current in normal operation, delivering current proportional to the load according to known ratio named K
- Diagnostics flag in fault conditions delivering fixed voltage V<sub>SENSEH</sub>

The current delivered by the current sense circuit, I<sub>SENSE</sub>, can be easily converted to a voltage V<sub>SENSE</sub> by using an external sense resistor, R<sub>SENSE</sub>, allowing continuous load monitoring and abnormal condition detection.

**Normal operation (channel ON, no fault, SEn active)**

While device is operating in normal conditions (no fault intervention), V<sub>SENSE</sub> calculation can be done using simple equations

Current provided by CurrentSense output: I<sub>SENSE</sub> = I<sub>OUT</sub>/K

Voltage on R<sub>SENSE</sub>: V<sub>SENSE</sub> = R<sub>SENSE</sub> \* I<sub>SENSE</sub> = R<sub>SENSE</sub> \* I<sub>OUT</sub>/K

Where :

- $V_{SENSE}$  is voltage measurable on  $R_{SENSE}$  resistor
- $I_{SENSE}$  is current provided from CS pin in current output mode
- $I_{OUT}$  is current flowing through output
- K factor represents the ratio between PowerMOS cells and SenseMOS cells; its spread includes geometric factor spread, current sense amplifier offset and process parameters spread of overall circuitry specifying ratio between  $I_{OUT}$  and  $I_{SENSE}$ .

**Failure flag indication**

In case of power limitation/overtemperature, the fault is indicated by the CS pin which is switched to a “current limited” voltage source,  $V_{SENSEH}$ .

In any case, the current sourced by the CS in this condition is limited to  $I_{SENSEH}$

**Figure 32: Analogue HSD – open-load detection in off-state**

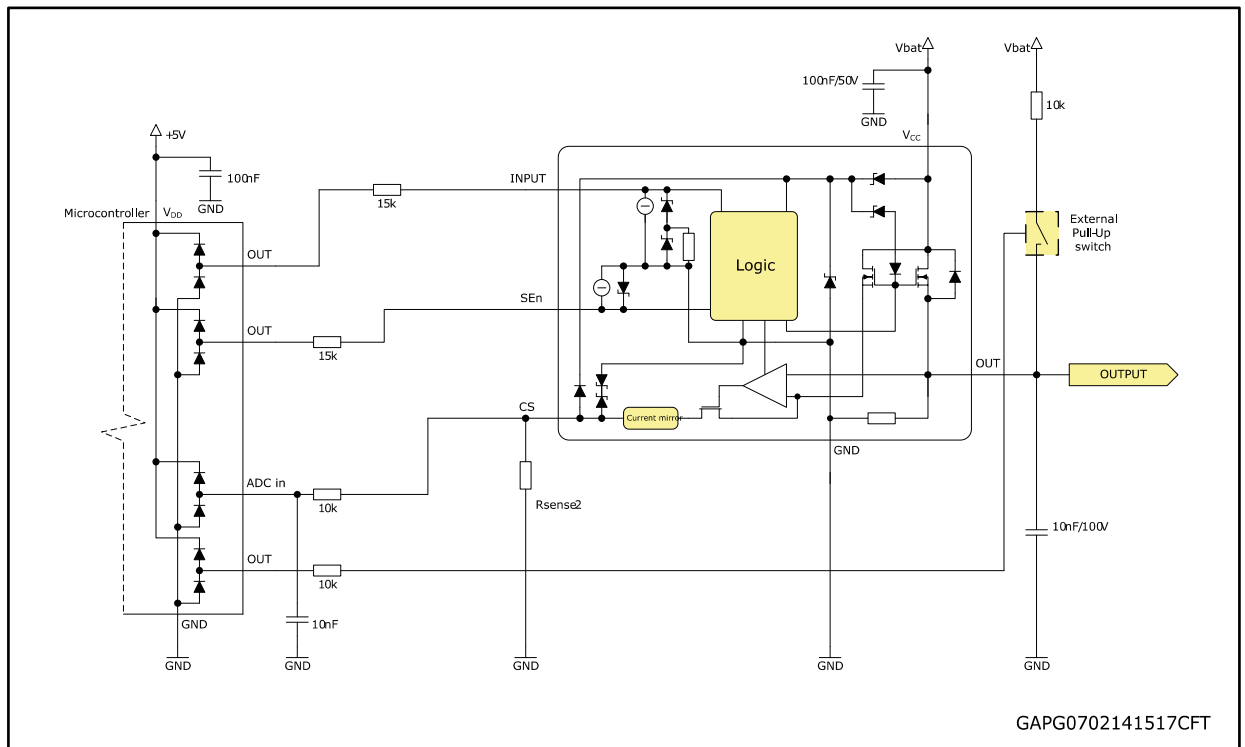
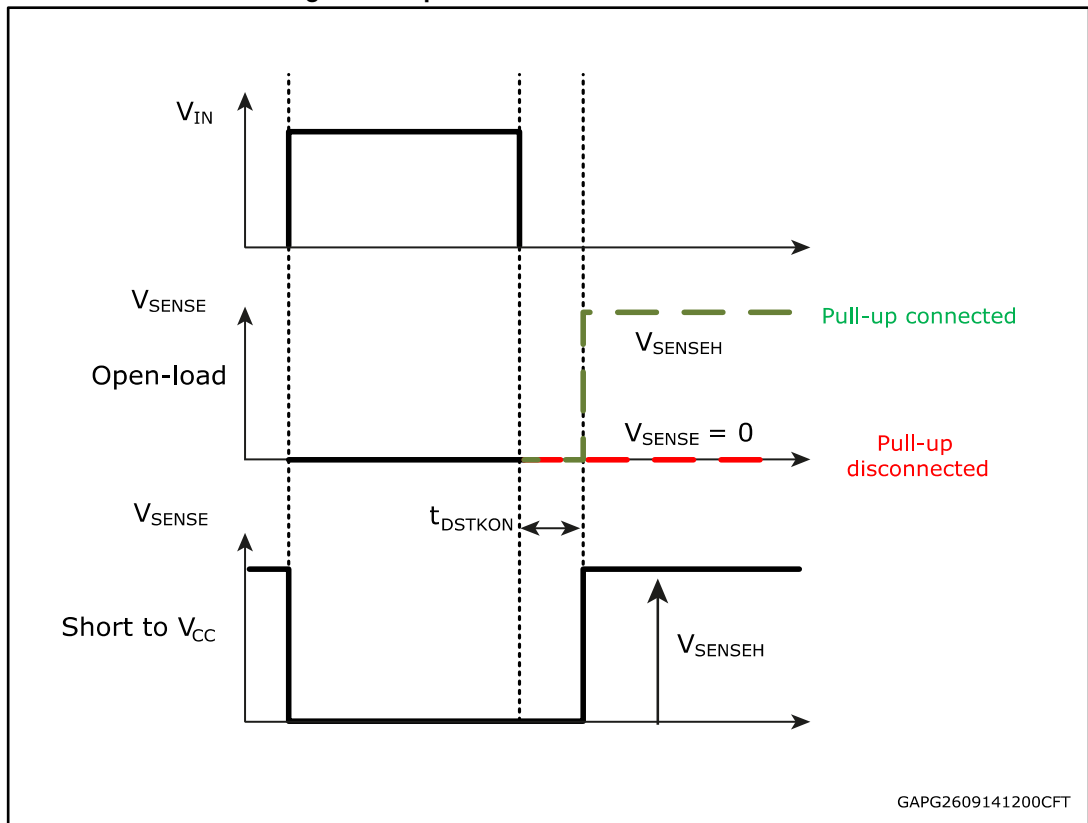



Figure 33: Open-load / short to VCC condition



GAPG2609141200CFT

Table 13: CurrentSense pin levels in off-state

| Condition         | Output             | CurrentSense | SEn |
|-------------------|--------------------|--------------|-----|
| Open-load         | $V_{OUT} > V_{OL}$ | Hi-Z         | L   |
|                   |                    | $V_{SENSEH}$ | H   |
|                   | $V_{OUT} < V_{OL}$ | Hi-Z         | L   |
|                   |                    | 0            | H   |
| Short to $V_{CC}$ | $V_{OUT} > V_{OL}$ | Hi-Z         | L   |
|                   |                    | $V_{SENSEH}$ | H   |
| Nominal           | $V_{OUT} < V_{OL}$ | Hi-Z         | L   |
|                   |                    | 0            | H   |

#### 4.4.2 Short to VCC and OFF-state open-load detection

##### Short to $V_{CC}$

A short circuit between  $V_{CC}$  and output is indicated by the relevant current sense pin set to  $V_{SENSEH}$  during the device off-state. Small or no current is delivered by the current sense during the on-state depending on the nature of the short circuit.

##### OFF-state open-load with external circuitry

Detection of an open-load in off mode requires an external pull-up resistor  $R_{PU}$  connecting the output to a positive supply voltage  $V_{PU}$ .

It is preferable  $V_{PU}$  to be switched off during the module standby mode in order to avoid the overall standby current consumption to increase in normal conditions, i.e. when load is connected.

$R_{PU}$  must be selected in order to ensure  $V_{OUT} > V_{OLmax}$  in accordance with the following equation:

Equation

$$R_{PU} < \frac{V_{PU} - 4}{I_{L(off)min @ 4V}}$$

Figure 34: Maximum turn off current vs. inductance

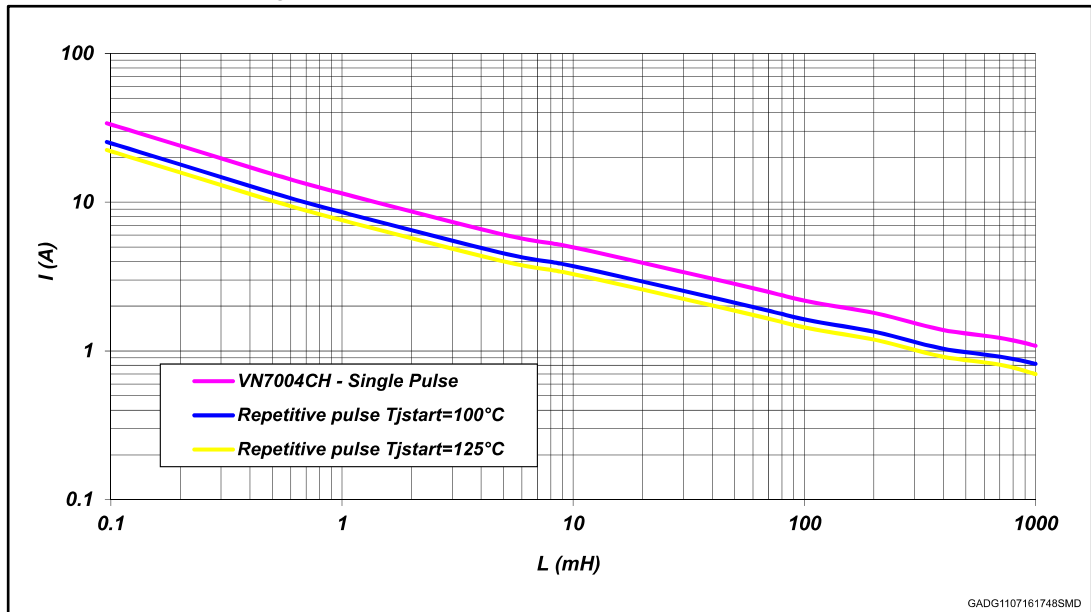

## 5 Package and PCB thermal data

### 5.1 Octapak thermal data

Figure 35: Octapak on two-layers PCB (2s0p to JEDEC JESD 51-5)

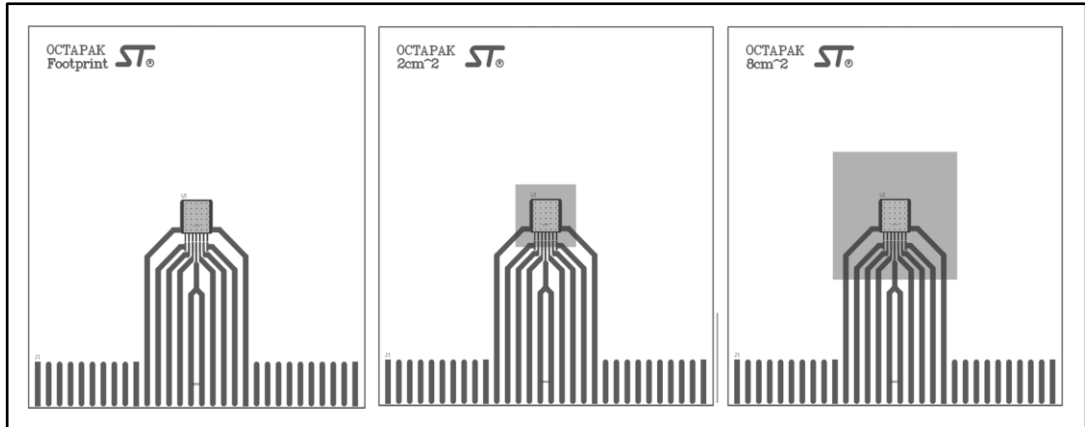

Figure 36: Octapak on four-layers PCB (2s2p to JEDEC JESD 51-7)

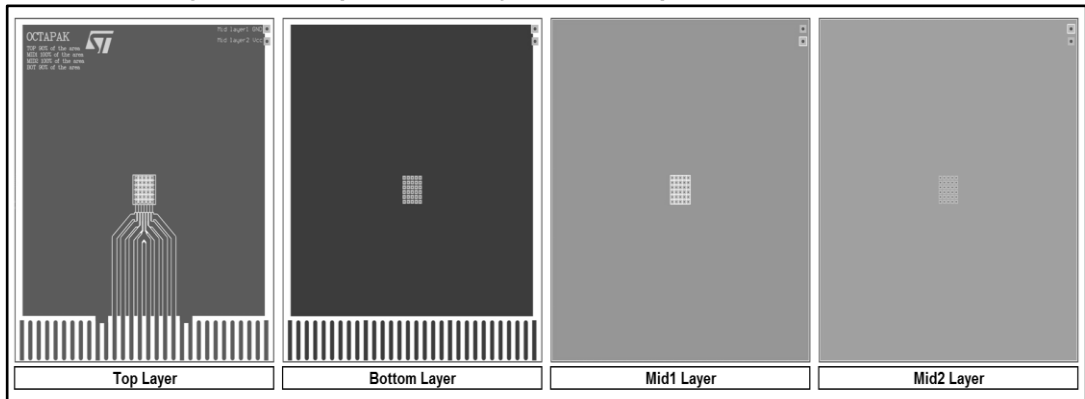

Table 14: PCB properties

| Dimension                                     | Value   |
|---|---|
| Board finish thickness                        | 1.6 mm +/- 10%                                    |
| Board dimension                               | 77 mm x 86 mm                                     |
| Board material                                | FR4   |
| Copper thickness (top and bottom layers)      | 0.070 mm  |
| Copper thickness (inner layers)               | 0.035 mm  |
| Thermal vias separation                       | 1.2 mm  |
| Thermal via diameter                          | 0.3 mm +/- 0.08 mm                                |
| Copper thickness on vias                      | 0.025 mm  |
| Footprint dimension (top layer)               | 6.4 mm x 7mm                                      |
| Heatsink copper area dimension (bottom layer) | Footprint, 2 cm <sup>2</sup> or 8 cm <sup>2</sup> |

Figure 37: Rthj-amb vs PCB copper area in open box free air conditions

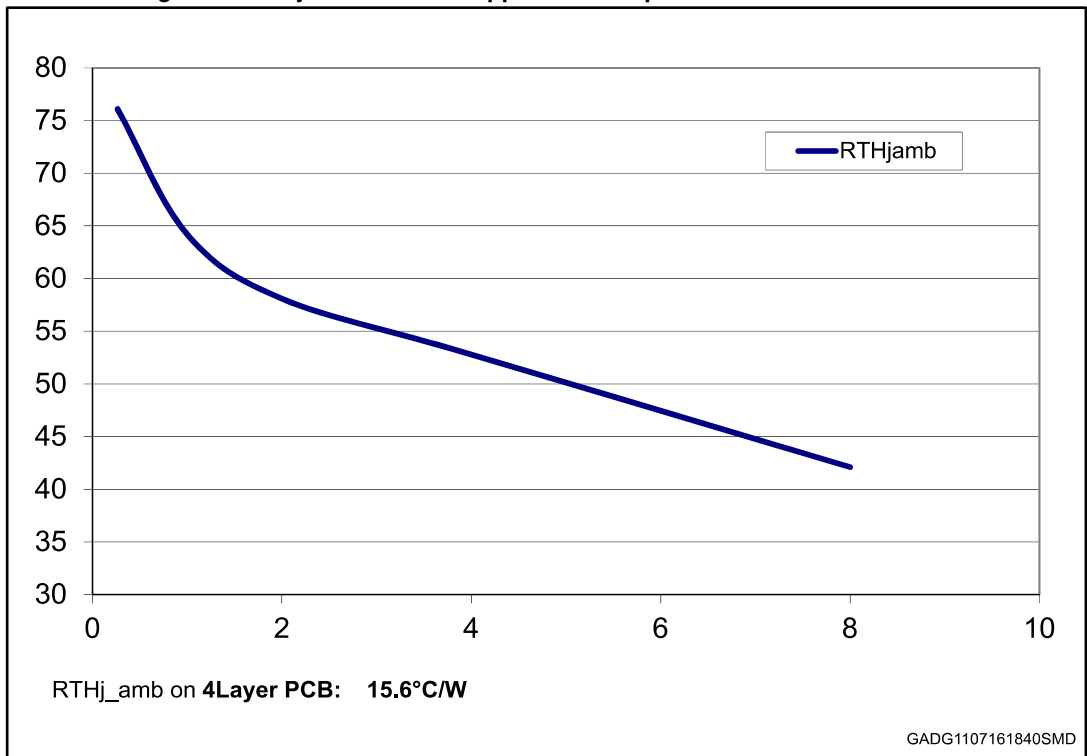
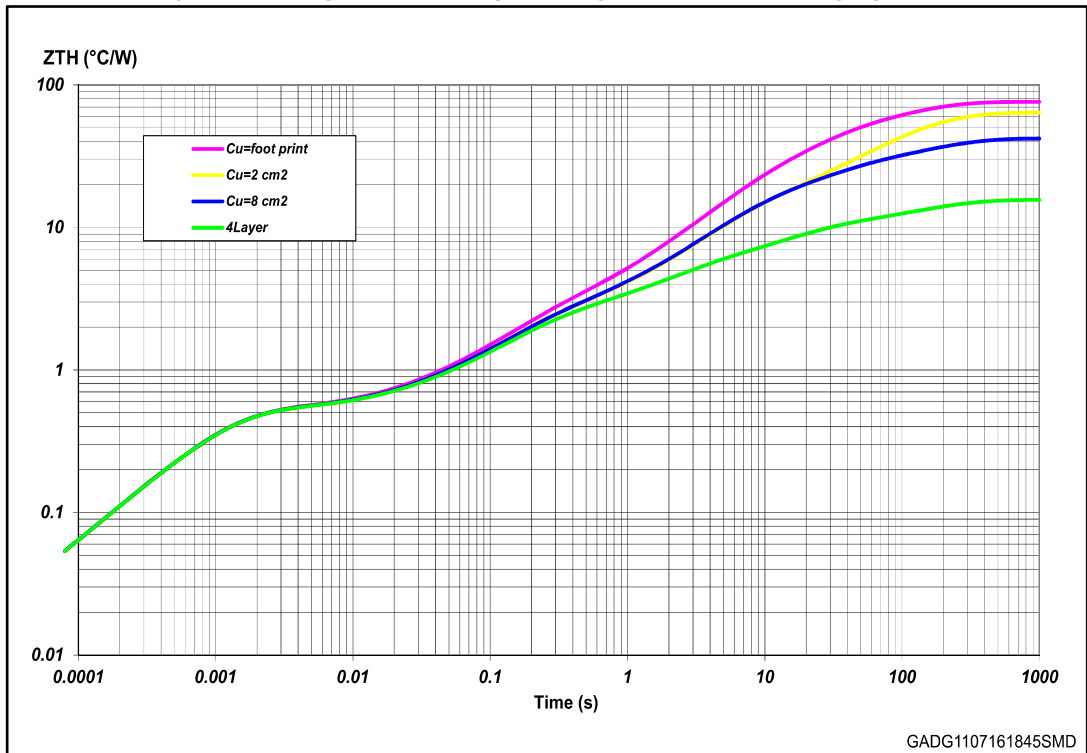

Figure 38: Octapak thermal impedance junction ambient single pulse



**Equation: Pulse calculation formula**

$$Z_{TH\delta} = R_{TH} \cdot + Z_{THtp} (1 - \delta)$$

where  $\delta = t_p/T$

**Figure 39: Thermal fitting model for Octapak**

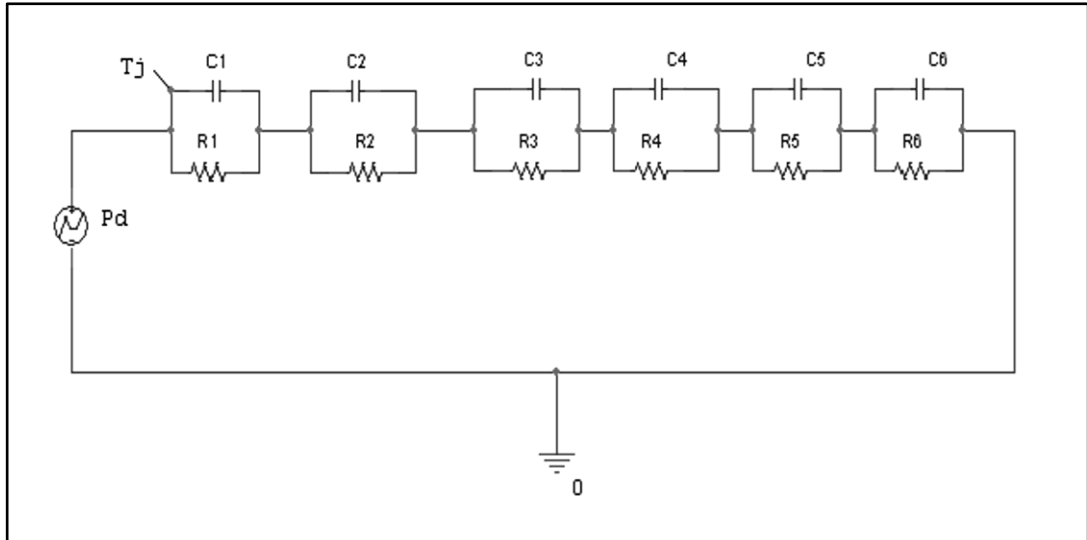

The fitting model is a simplified thermal tool and is valid for transient evolutions where the embedded protections (power limitation or thermal cycling during thermal shutdown) are not triggered.

**Table 15: Thermal parameters**

| Area/island (cm <sup>2</sup> ) | Footprint | 2      | 8      | 4L     |
|--------------------------------|-----------|--------|--------|--------|
| R1 (°C/W)                      | 0.01      | 0.01   | 0.01   | 0.01   |
| R2 (°C/W)                      | 0.5       | 0.5    | 0.5    | 0.5    |
| R3 (°C/W)                      | 1.6       | 1.6    | 1.6    | 1.6    |
| R4 (°C/W)                      | 10        | 10     | 10     | 2.5    |
| R5 (°C/W)                      | 28        | 20     | 12     | 5      |
| R6 (°C/W)                      | 36        | 26     | 18     | 6      |
| C1 (W.s/°C)                    | 0.001     | 0.001  | 0.001  | 0.001  |
| C2 (W.s/°C)                    | 0.0018    | 0.0018 | 0.0018 | 0.0018 |
| C3 (W.s/°C)                    | 0.11      | 0.11   | 0.11   | 0.11   |
| C4 (W.s/°C)                    | 0.6       | 0.6    | 0.6    | 0.8    |
| C5 (W.s/°C)                    | 0.8       | 1.4    | 2.2    | 3      |
| C6 (W.s/°C)                    | 3         | 6      | 9      | 25     |

## 6 Package information

In order to meet environmental requirements, ST offers these devices in different grades of ECOPACK® packages, depending on their level of environmental compliance. ECOPACK® specifications, grade definitions and product status are available at: [www.st.com](http://www.st.com). ECOPACK® is an ST trademark.

### 6.1 Octapak package information

Figure 40: Octapak package dimensions

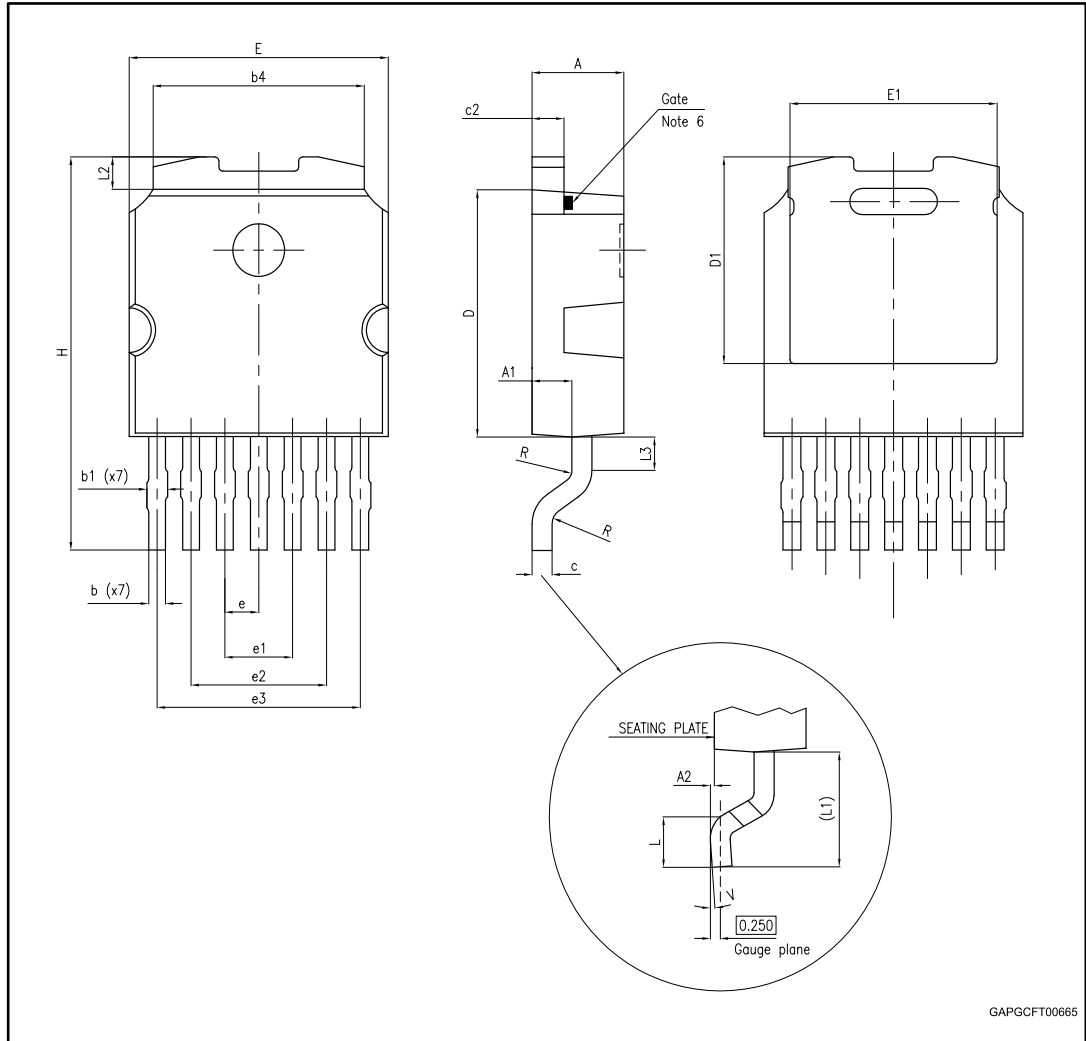

Table 16: Octapak mechanical data

| Symbol | Millimeters |      |      |
|--------|-------------|------|------|
|        | Min.        | Typ. | Max. |
| A      | 2.20        | 2.30 | 2.40 |
| A1     | 0.90        | 1.00 | 1.10 |
| A2     | 0.03        |      | 0.15 |
| b      | 0.38        | 0.45 | 0.52 |

| Symbol | Millimeters |      |       |
|--------|-------------|------|-------|
|        | Min.        | Typ. | Max.  |
| b1     |             |      | 0.70  |
| b4     | 5.20        | 5.30 | 5.40  |
| c      | 0.45        | 0.50 | 0.60  |
| c2     | 0.75        | 0.80 | 0.90  |
| D      | 6.00        | 6.10 | 6.20  |
| D1     |             | 5.15 |       |
| E      | 6.40        | 6.50 | 6.60  |
| E1     |             | 5.30 |       |
| e      | 0.85 BSC    |      |       |
| e1     | 1.60        | 1.70 | 1.80  |
| e2     | 3.30        | 3.40 | 3.50  |
| e3     | 5.00        | 5.10 | 5.20  |
| H      | 9.35        | 9.70 | 10.10 |
| L      | 1.00        |      | —     |
| (L1)   |             | 2.80 |       |
| L2     |             | 0.80 |       |
| L3     |             | 0.85 |       |
| R      | 0.40 BSC    |      |       |
| V2     | 0°          |      | 8°    |

## 6.2 Octapak packing information

Figure 41: Octapak reel 13"

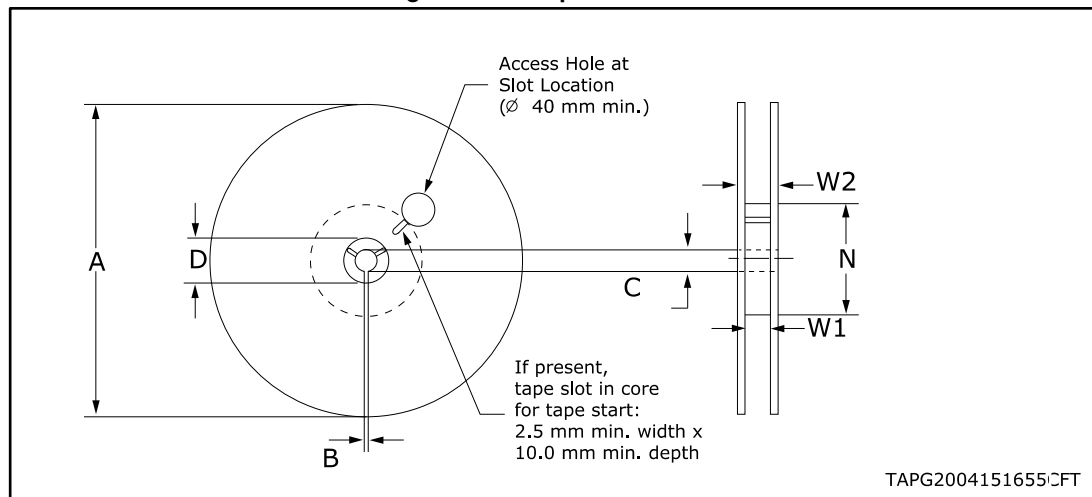

Table 17: Reel dimensions

| Description    | Value <sup>(1)</sup> |
|----------------|----------------------|
| Base quantity  | 2500                 |
| Bulk quantity  | 2500                 |
| A (max)        | 330                  |
| B (min)        | 1.5                  |
| C (+0.5, -0.2) | 13                   |
| D              | 20.2                 |
| N              | 100                  |
| W1 (+2 /-0)    | 16.4                 |
| W2 (max)       | 22.4                 |

**Notes:**

(1)All dimensions are in mm.

Figure 42: Octapak carrier tape

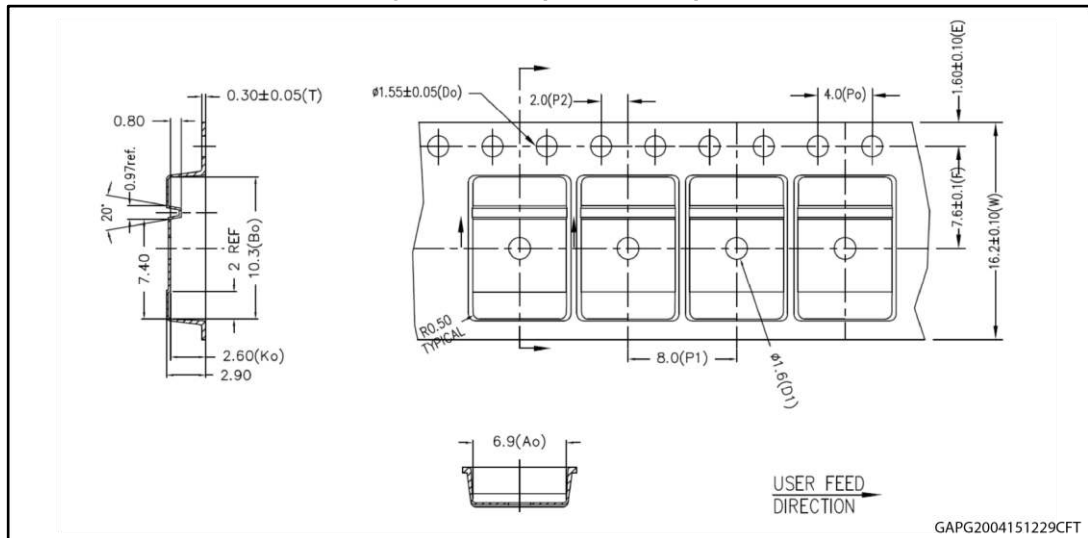
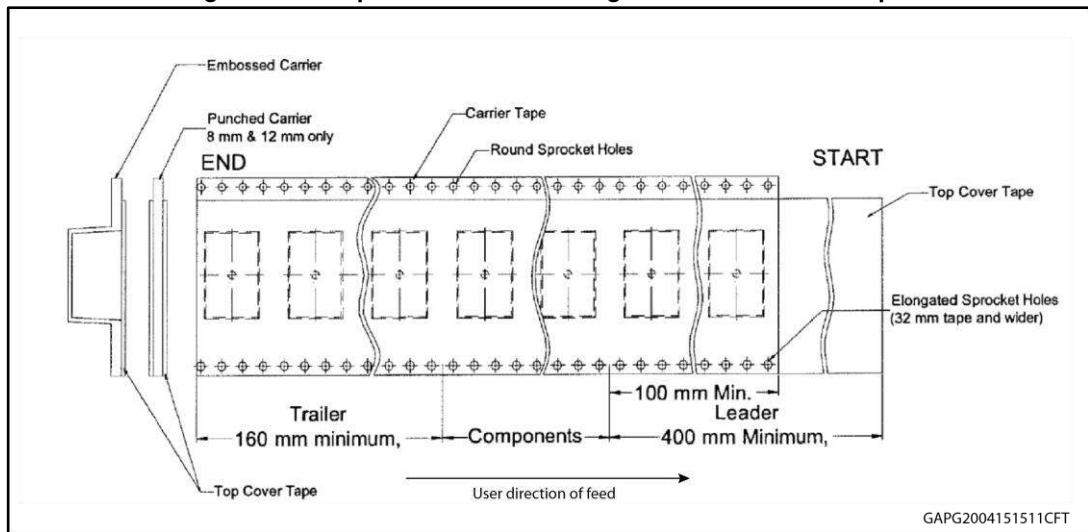

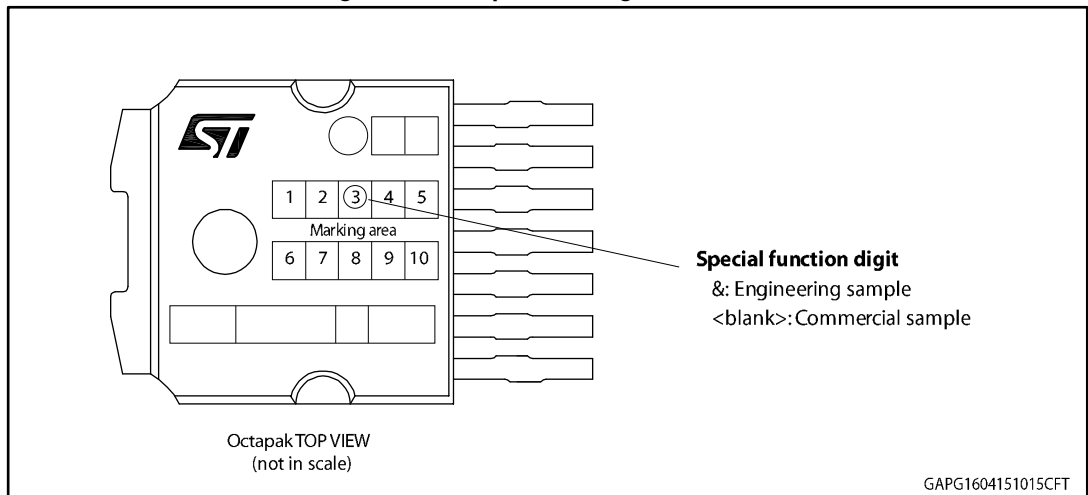

Figure 43: Octapak schematic drawing of leader and trailer tape



### 6.3 Octapak marking information

Figure 44: Octapak marking information



Parts marked as "&" are not yet qualified and therefore not approved for use in production. ST is not responsible for any consequences resulting from such use. In no event will ST be liable for the customer using any of these engineering samples in production. ST's Quality department must be contacted prior to any decision to use these engineering samples to run a qualification activity.

## 7 Revision history

**Table 18: Document revision history**

| Date        | Revision | Changes  |
|-------------|----------|--|
| 21-Apr-2015 | 1        | Initial release  |
| 06-Aug-2015 | 2        | <p><i>Table 4: "Absolute maximum ratings":</i></p> <ul style="list-style-type: none"> <li>• <math>V_{CC\_LSC}</math>: removed row</li> <li>• <math>E_{MAX}</math>: updated value</li> </ul> <p><i>Table 6: "Power section":</i></p> <ul style="list-style-type: none"> <li>• <math>I_{STBY}</math>, <math>I_{L(off)}</math>: updated values</li> </ul> <p>Updated <i>Table 7: "Switching"</i></p> <p><i>Table 9: "Protection":</i></p> <ul style="list-style-type: none"> <li>• <math>I_{LIMH}</math>: updated values</li> </ul> <p><i>Table 10: "CurrentSense":</i></p> <ul style="list-style-type: none"> <li>• <math>K_x</math>, <math>dK_x/K_x</math>, <math>I_{SENSE0}</math>, <math>I_{OUT\_SAT}</math>: updated values</li> </ul> |
| 12-Nov-2015 | 3        | <p>Updated <i>Section "Features"</i></p> <p><i>Table 6: "Power section":</i></p> <ul style="list-style-type: none"> <li>• <math>I_{STBY}</math>, <math>I_{L(off)}</math>: updated values</li> </ul> <p><i>Table 10: "CurrentSense":</i></p> <ul style="list-style-type: none"> <li>• <math>dK_x/K_x</math>: updated values</li> </ul>  |
| 27-Apr-2016 | 4        | <p>Updated <i>Figure 1: "Block diagram"</i></p> <p><i>Table 10: "CurrentSense":</i></p> <ul style="list-style-type: none"> <li>• <math>K_3</math>: updated values</li> </ul>   |

| Date        | Revision | Changes   |
|-------------|----------|---|
| 12-Jul-2016 | 5        | <p><i>Section "Features":</i></p> <ul style="list-style-type: none"> <li>Current limitation (typ): updated value</li> </ul> <p><i>Table 4: "Absolute maximum ratings":</i></p> <ul style="list-style-type: none"> <li><math>E_{MAX}</math>: updated <math>T_{DEMAG}</math> parameter and value</li> </ul> <p><i>Table 5: "Thermal data":</i></p> <ul style="list-style-type: none"> <li>Updated all <math>T_{yp}</math> values and <math>R_{thj-case}</math> term</li> </ul> <p><i>Table 7: "Switching":</i></p> <ul style="list-style-type: none"> <li><math>(dV_{OUT}/dt)_{on}</math>, <math>(dV_{OUT}/dt)_{off}</math>, <math>W_{ON}</math>, <math>W_{OFF}</math>, <math>t_{SKEW}</math>: updated values</li> </ul> <p><i>Table 9: "Protection":</i></p> <ul style="list-style-type: none"> <li><math>I_{LIMH}</math>, <math>I_{LIML}</math>: updated typ and max values</li> <li><math>\Delta T_{J\_SD}</math>: removed <math>T_j</math> test condition</li> </ul> <p><i>Table 10: "CurrentSense":</i></p> <ul style="list-style-type: none"> <li><math>V_{SENSE\_SAT}</math>, <math>I_{SENSE\_SAT}</math>, <math>I_{OUT\_SAT}</math>: updated test conditions</li> <li><math>t_{DSENSE2H}</math>: updated max value</li> </ul> <p><i>Section 2.3: "Electrical characteristics":</i></p> <ul style="list-style-type: none"> <li>Added <i>Figure 4: "IOUT/ISENSE vs. IOUT"</i> and <i>Figure 5: "Current sense precision vs. IOUT"</i></li> </ul> <p>Added <i>Section 2.4: "Electrical characteristics curves"</i></p> <p><i>Section 4.4.2: "Short to VCC and OFF-state open-load detection":</i></p> <ul style="list-style-type: none"> <li>Added <i>Figure 34: "Maximum turn off current vs. inductance"</i></li> </ul> <p><i>Section 6.1: "Octapak thermal data":</i></p> <ul style="list-style-type: none"> <li>Updated <i>Figure 35: "Octapak on two-layers PCB (2s0p to JEDEC JESD 51-5)"</i>, <i>Figure 36: "Octapak on four-layers PCB (2s2p to JEDEC JESD 51-7)"</i>, <i>Figure 37: "Rthj-amb vs PCB copper area in open box free air conditions"</i>, <i>Figure 38: "Octapak thermal impedance junction ambient single pulse"</i>, <i>Figure 39: "Thermal fitting model for Octapak"</i>, and <i>Table 15: "Thermal parameters"</i></li> </ul> <p>Minor text corrections throughout the document</p> |
| 09-Nov-2016 | 6        | Updated Applications section  |

**IMPORTANT NOTICE – PLEASE READ CAREFULLY**

STMicroelectronics NV and its subsidiaries ("ST") reserve the right to make changes, corrections, enhancements, modifications, and improvements to ST products and/or to this document at any time without notice. Purchasers should obtain the latest relevant information on ST products before placing orders. ST products are sold pursuant to ST's terms and conditions of sale in place at the time of order acknowledgement.

Purchasers are solely responsible for the choice, selection, and use of ST products and ST assumes no liability for application assistance or the design of Purchasers' products.

No license, express or implied, to any intellectual property right is granted by ST herein.

Resale of ST products with provisions different from the information set forth herein shall void any warranty granted by ST for such product.

ST and the ST logo are trademarks of ST. All other product or service names are the property of their respective owners.

Information in this document supersedes and replaces information previously supplied in any prior versions of this document.

© 2016 STMicroelectronics – All rights reserved