

THIS DRAWING IS UNPUBLISHED. RELEASED FOR PUBLICATION 2004  
 © COPYRIGHT 2004 BY - ALL RIGHTS RESERVED.

REVISIONS					
P	LTR	DESCRIPTION	DATE	DWN	APVD
B		RELEASED, ECR-05-004319	24JUN2005	UA	GT
B1		ADDED DASH 3	9APR2008	HY	GT
B2		ECR-16-006049	29APR2016	KD	RR
B3		ECR-16-013131	19SEP2016	RS	LP

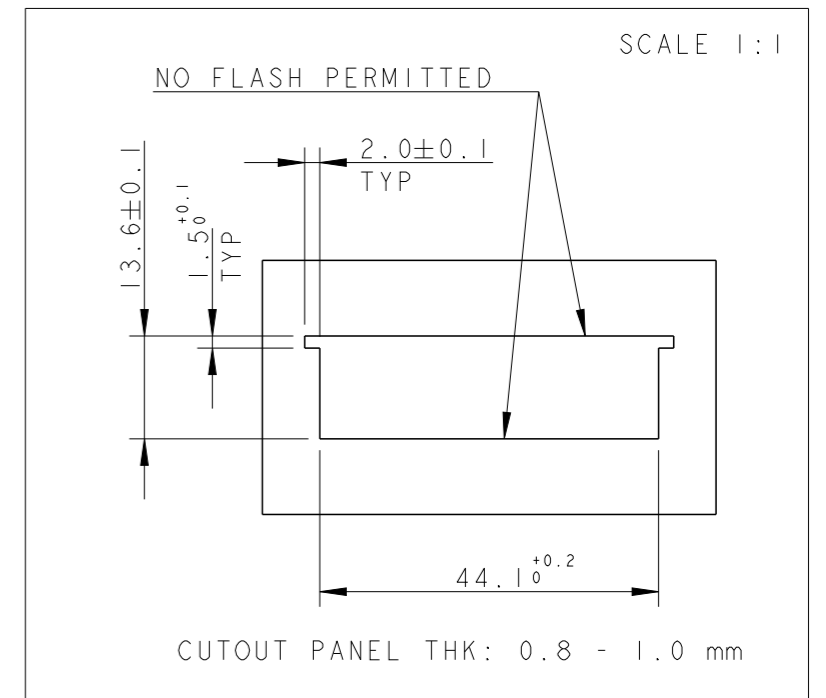
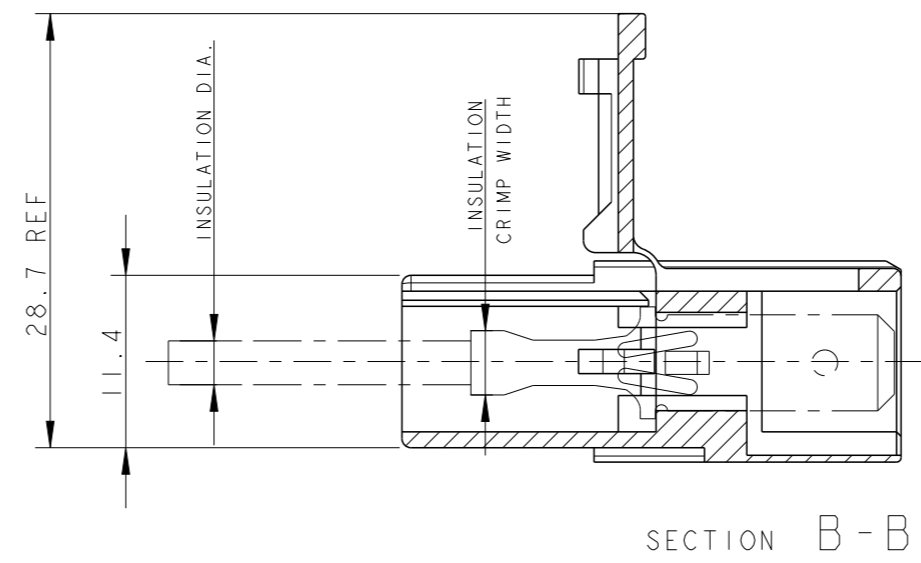
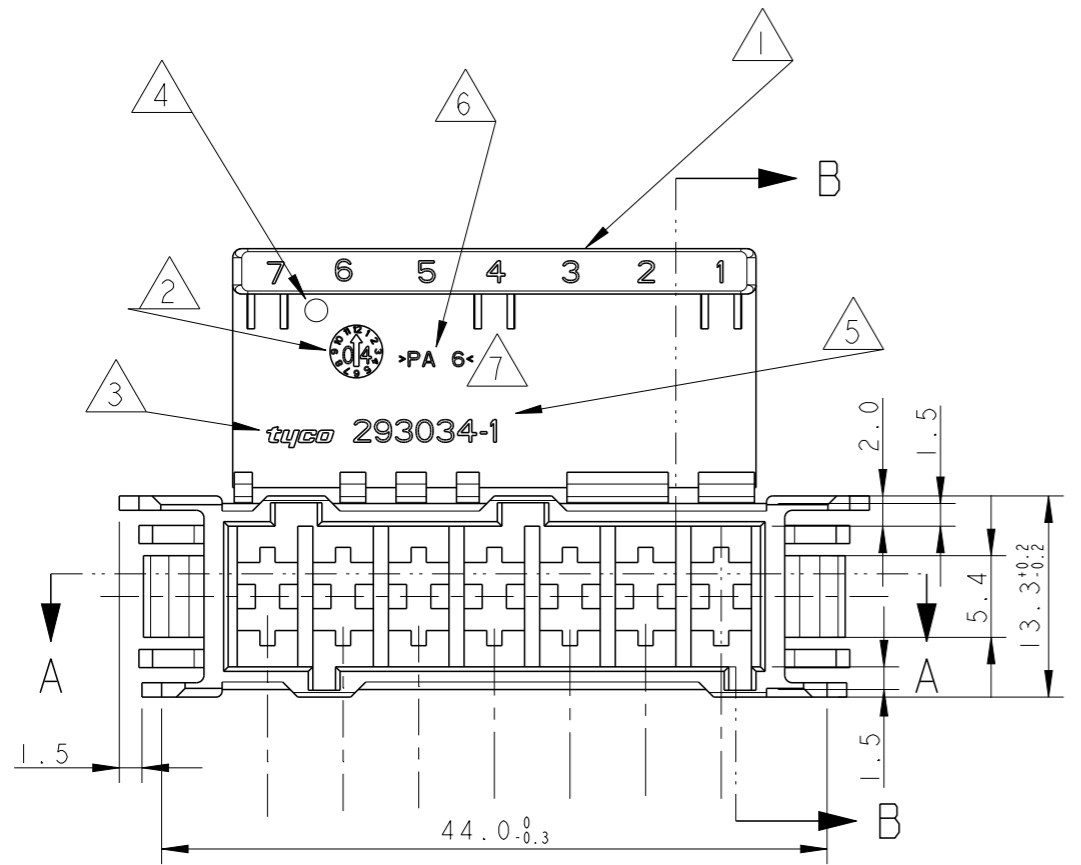

NOTES:

- ① CIRCUIT IDENTIFICATION NUMBERS 1 TO 7, BOTH SIDES
- ② DATE CODE
- ③ TYCO TRADEMARK
- ④ MOULD CAVITY IDENTIFICATION
- ⑤ TE - AMP P/N
- ⑥ RAW MATERIAL CODE
- ⑦ MATERIAL: PA6 UNFILLED UL 94-V2, NATURAL COLOR
- 8) CONNECTOR HOUSING SUITABLE FOR MATING WITH:  
 (PROPERLY CODED WITH RELEVANT APPLICATION MACHINE)  
 - AMP MONOSHAP Mark I TAB CONNECTOR, P/N 1-293004-7  
 - AMP MONOSHAP Mark II TAB CONNECTOR, P/N x-284477-2
- 9) CAVITIES SUITABLE FOR .250" SERIES FASTIN-ON TAB CONTACT  
 ACCORDING TO NORM "DIN 46 343"  
 MAX INS. DIA.: 2.8 mm; MAX INS. CRIMP WIDTH: 3.3 mm
- ⑩ MATERIAL: PA66 UNFILLED UL 94-V0, NATURAL COLOR
- ⑪ MATERIAL: PA66 UNFILLED UL 94-V0, GWT 750 NO FLAME, NATURAL COLOR
- ⑫ PRELIMINARY - NOT RELEASED FOR PRODUCTION

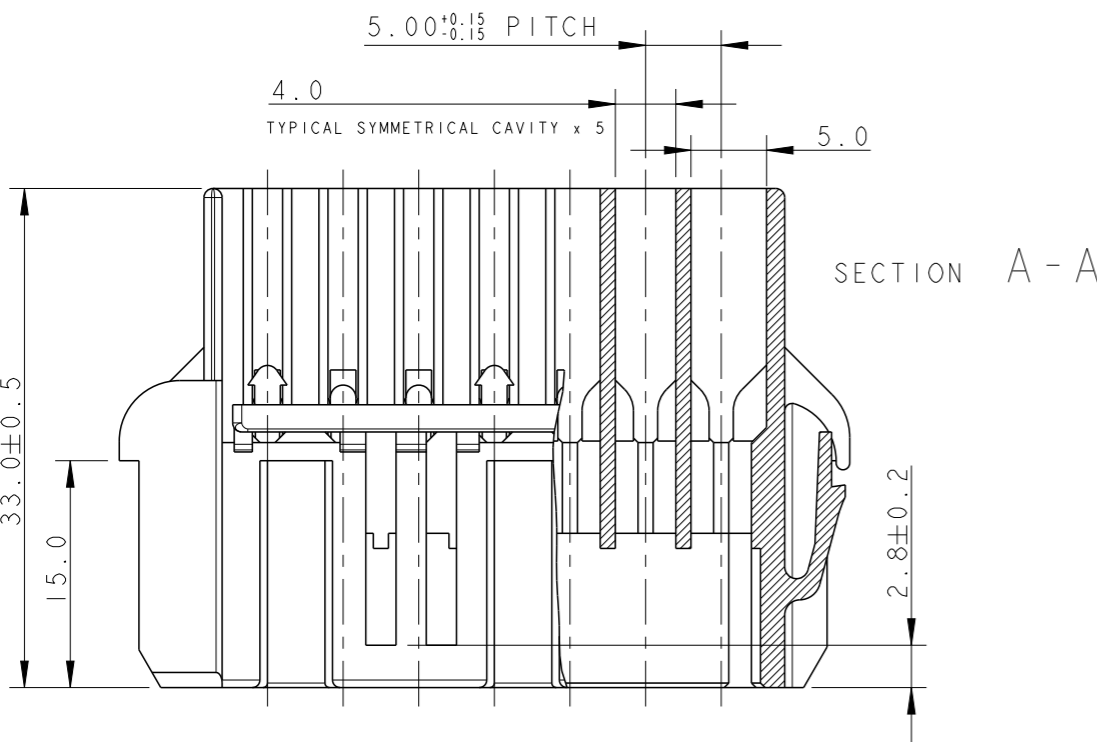
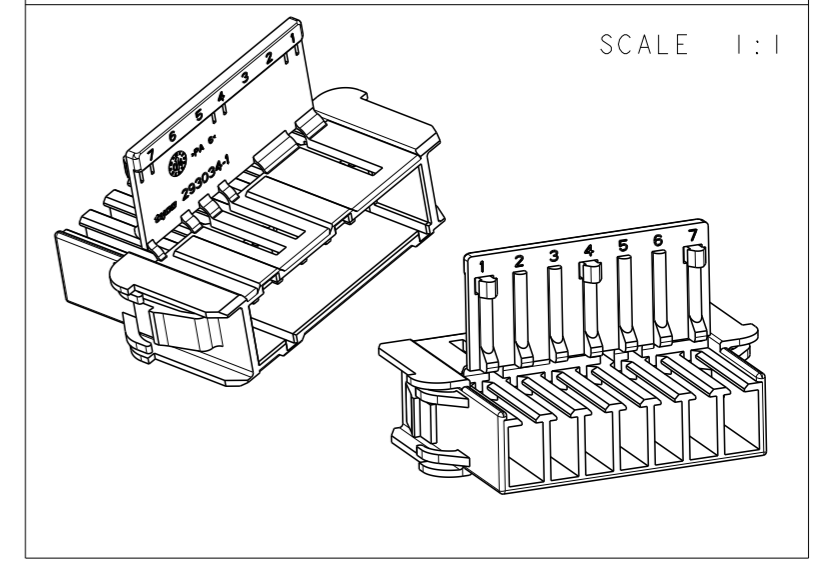

MATERIAL	P/N	REV.
SEE NOTE 7	293034-1	B
SEE NOTE 11	293034-2 ⑫	I
SEE NOTE 10	293034-3	B

THIS DRAWING IS A CONTROLLED DOCUMENT.		DWN U. AIME 17MAY2004	TE Connectivity	
DIMENSIONS: mm		CHK C. TARTARI 17MAY2004		
TOLERANCES UNLESS OTHERWISE SPECIFIED:		APVD C. TARTARI 17MAY2004		
0 PLC ±- 1 PLC ±0.3 2 PLC ±- 3 PLC ±- 4 PLC ±- ANGLES ±1° MATERIAL SEE NOTE FINISH -		PRODUCT SPEC 108-20256 APPLICATION SPEC - WEIGHT 8.9 g		
		NAME 7 POSITION FASTIN-FASTON TAB HOUSING, 5 mm PITCH (PANEL MOUNT VERSION)		RESTRICTED TO -
		SIZE A300779 C-293034		
		CUSTOMER DRAWING SCALE 2:1 SHEET 1 OF 1 REV B3		