



FemtoClock® Crystal-to-LVCMOS/ LVTTTL Clock Generator

840011

PRODUCT DISCONTINUATION NOTICE - LAST TIME BUY EXPIRES MAY 6, 2017

DATA SHEET

GENERAL DESCRIPTION

The 840011 is a Fibre Channel Clock Generator and a member of the family of high performance devices from IDT. The 840011 uses a 26.5625MHz or 25MHz crystal to synthesize 106.25MHz or 100MHz respectively. The 840011 has excellent phase jitter performance, from 637kHz – 10MHz integration range. The 840011 is packaged in a small 8-pin TSSOP, making it ideal for use in systems with limited board space.

FEATURES

- One LVCMOS/LVTTTL output, 7Ω output impedance
- Crystal oscillator interface designed for 26.5625MHz or 25MHz, 18pF parallel resonant crystal
- Output frequency: 106.25MHz (typical)
- VCO range: 560MHz to 680MHz
- RMS phase jitter @ 106.25MHz, using a 26.5625MHz crystal (637KHz - 10MHz): 0.780ps (typical)
- RMS phase noise at 125MHz:

Offset	Noise Power
100Hz	-95.7 dBc/Hz
1kHz	-121 dBc/Hz
10kHz	-129 dBc/Hz
100kHz	-129.6 dBc/Hz
- 3.3V operating supply
- -30°C to 85°C ambient operating temperature
- Available in lead-free (RoHS 6) package
- **Not Recommended for New Designs**
- **For drop in replacement part use 840N011i**

FREQUENCY TABLE

Inputs	Output Frequency (MHz)
Crystal Frequency (MHz)	
26.5625	106.25
25	100

BLOCK DIAGRAM

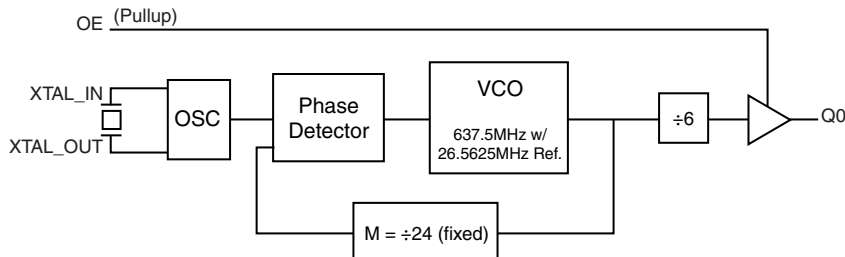

PIN ASSIGNMENT

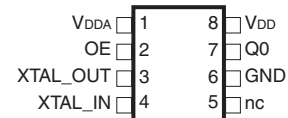

840011

8-Lead TSSOP

4.40mm x 3.0mm x 0.925mm package body

G Package

Top View

TABLE 1. PIN DESCRIPTIONS

Number	Name	Type		Description
1	V _{DDA}	Power		Analog supply pin.
2	OE	Input	Pullup	Output enable pin. When HIGH, Q0 output is enabled. When LOW, forces Q0 to HiZ state. LVCMOS/LVTTL interface levels.
3, 4	XTAL_OUT, XTAL_IN	Input		Crystal oscillator interface. XTAL_IN is the input, XTAL_OUT is the output.
5	nc	Unused		No connect.
6	GND	Power		Power supply ground.
7	Q0	Output		Single-ended clock output. LVCMOS/LVTTL interface levels. 7Ω output impedance.
8	V _{DD}	Power		Core supply pin.

NOTE: *Pullup* refers to internal input resistors. See Table 2, Pin Characteristics, for typical values.

TABLE 2. PIN CHARACTERISTICS

Symbol	Parameter	Test Conditions	Minimum	Typical	Maximum	Units
C _{IN}	Input Capacitance			4		pF
C _{PD}	Power Dissipation Capacitance	V _{DD} , V _{DDA} = 3.465V		24		pF
R _{PULLUP}	Input Pullup Resistor			51		kΩ
R _{OUT}	Output Impedance		5	7	12	Ω

TABLE 3. CONTROL FUNCTION TABLE

Control Inputs	Output
OE	Q0
0	Hi-Z
1	Active

ABSOLUTE MAXIMUM RATINGS

Supply Voltage, V_{DD}	4.6V
Inputs, V_I	-0.5V to $V_{DD} + 0.5V$
Outputs, V_O	-0.5V to $V_{DD} + 0.5V$
Package Thermal Impedance, θ_{JA}	101.7°C/W (0 mps)
Storage Temperature, T_{STG}	-65°C to 150°C

NOTE: Stresses beyond those listed under Absolute Maximum Ratings may cause permanent damage to the device. These ratings are stress specifications only. Functional operation of product at these conditions or any conditions beyond those listed in the *DC Characteristics* or *AC Characteristics* is not implied. Exposure to absolute maximum rating conditions for extended periods may affect product reliability.

TABLE 4A. POWER SUPPLY DC CHARACTERISTICS, $V_{DD} = V_{DDA} = 3.3V \pm 5\%$, $T_A = -30^\circ\text{C}$ TO 85°C

Symbol	Parameter	Test Conditions	Minimum	Typical	Maximum	Units
V_{DD}	Core Supply Voltage		3.135	3.3	3.465	V
V_{DDA}	Analog Supply Voltage		3.135	3.3	3.465	V
I_{DD}	Power Supply Current				80	mA
I_{DDA}	Analog Supply Current				10	mA

TABLE 4B. LVCMOS/LVTTL DC CHARACTERISTICS, $V_{DD} = V_{DDA} = 3.3V \pm 5\%$, $T_A = -30^\circ\text{C}$ TO 85°C

Symbol	Parameter	Test Conditions	Minimum	Typical	Maximum	Units
V_{IH}	Input High Voltage		2		$V_{DD} + 0.3$	V
V_{IL}	Input Low Voltage		-0.3		0.8	V
I_{IH}	Input High Current	OE $V_{DD} = V_{IN} = 3.465V$			5	μA
I_{IL}	Input Low Current	OE $V_{DD} = 3.465V, V_{IN} = 0V$	-150			μA
V_{OH}	Output High Voltage; NOTE 1		2.6			V
V_{OL}	Output Low Voltage; NOTE 1				0.5	V

NOTE 1: Outputs terminated with 50Ω to $V_{DD}/2$. See Parameter Measurement Information Section, "3.3V Output Load Test Circuit".

TABLE 5. CRYSTAL CHARACTERISTICS

Parameter	Test Conditions	Minimum	Typical	Maximum	Units
Mode of Oscillation		Fundamental			
Frequency				26.5625	MHz
Equivalent Series Resistance (ESR)				50	Ω
Shunt Capacitance				7	pF

TABLE 6. AC CHARACTERISTICS, $V_{DD} = V_{DDA} = 3.3V \pm 5\%$, $T_A = -30^\circ\text{C}$ TO 85°C

Symbol	Parameter	Test Conditions	Minimum	Typical	Maximum	Units
f_{OUT}	Output Frequency		93.33	106.25	113.33	MHz
$t_{jit}(\emptyset)$	RMS Phase Jitter (Random); NOTE 1	$f_{OUT} = 106.25\text{MHz}$, (637kHz to 10MHz)		0.780		ps
t_R / t_F	Output Rise/Fall Time	20% to 80%	250		600	ps
odc	Output Duty Cycle	$f_{OUT} = 106.25\text{MHz}$	48		52	%

All parameters are characterized @ 106.25MHz.
NOTE 1: Please refer to the Phase Noise Plot.

TYPICAL PHASE NOISE AT 106.25MHz

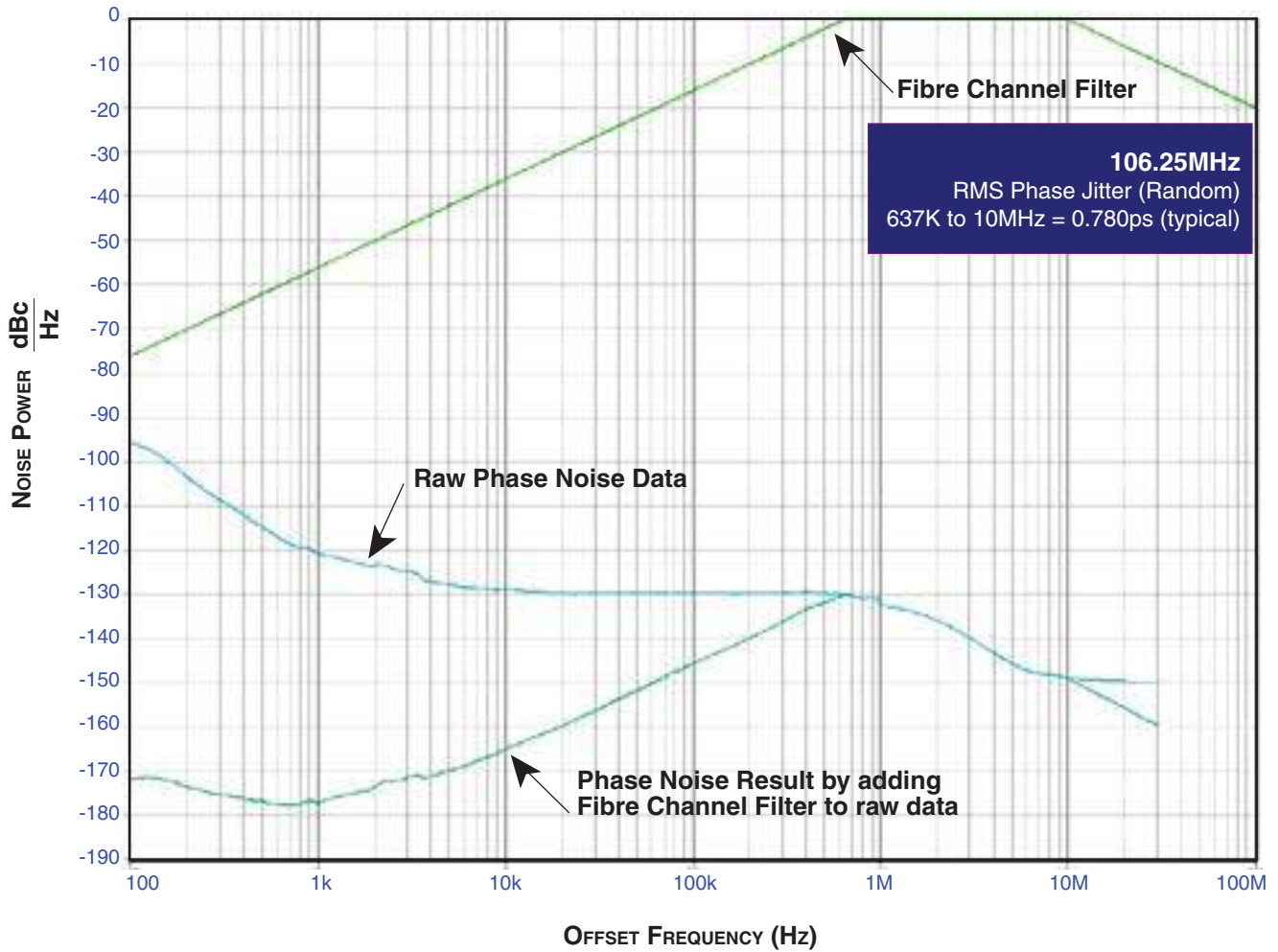

PARAMETER MEASUREMENT INFORMATION

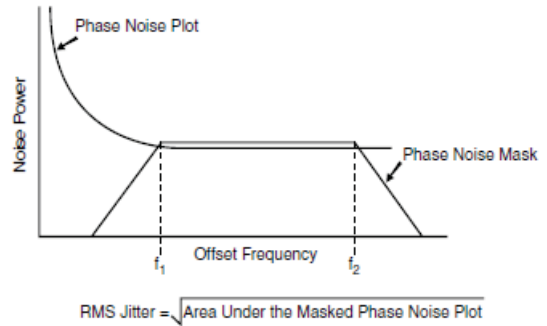
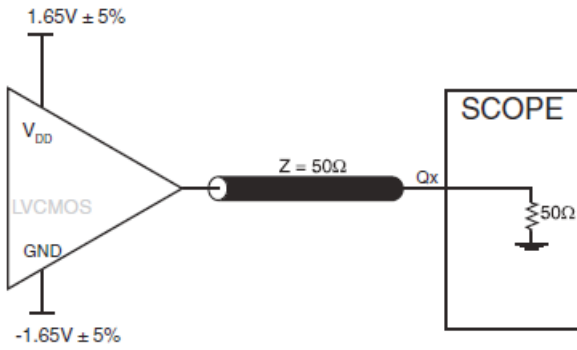

3.3V LVC MOS OUTPUT LOAD AC TEST CIRCUIT

RMS PHASE JITTER

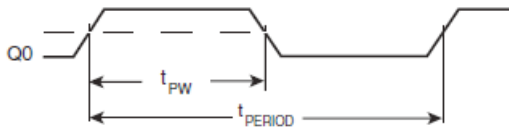

$$\text{odc} = \frac{t_{PW}}{t_{PERIOD}} \times 100\%$$

LVC MOS OUTPUT DUTY CYCLE/PULSE WIDTH/PERIOD



LVC MOS OUTPUT RISE/FALL TIME

APPLICATION INFORMATION

POWER SUPPLY FILTERING TECHNIQUES

As in any high speed analog circuitry, the power supply pins are vulnerable to random noise. The 840011 provides separate power supplies to isolate any high switching noise from the outputs to the internal PLL. V_{DD} and V_{DDA} should be individually connected to the power supply plane through vias, and bypass capacitors should be used for each pin. To achieve optimum jitter performance, power supply isolation is required. *Figure 1* illustrates how a 10Ω resistor along with a $10\mu\text{F}$ and a $.01\mu\text{F}$ bypass capacitor should be connected to each V_{DDA} pin.

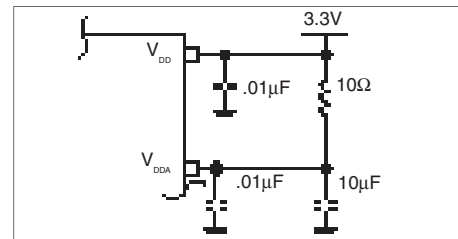

FIGURE 1. POWER SUPPLY FILTERING

CRYSTAL INPUT INTERFACE

The 840011 has been characterized with 18pF parallel resonant crystals. The capacitor values, $C1$ and $C2$, shown in *Figure 2* below were determined using a 26.5625MHz , 18pF

parallel resonant crystal and were chosen to minimize the ppm error. The optimum $C1$ and $C2$ values can be slightly adjusted for different board layouts.

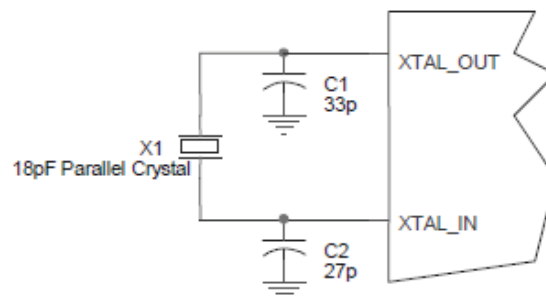

FIGURE 2. CRYSTAL INPUT INTERFACE

LVC MOS TO XTAL INTERFACE

The XTAL_IN input can accept a single-ended LVC MOS signal through an AC coupling capacitor. A general interface diagram is shown in *Figure 3*. The XTAL_OUT pin can be left floating. The input edge rate can be as slow as 10ns. For LVC MOS inputs, it is recommended that the amplitude be reduced from full swing to half swing in order to prevent signal interference with the power rail and to reduce noise. This configuration requires that the output

impedance of the driver (R_o) plus the series resistance (R_s) equals the transmission line impedance. In addition, matched termination at the crystal input will attenuate the signal in half. This can be done in one of two ways. First, R_1 and R_2 in parallel should equal the transmission line impedance. For most 50Ω applications, R_1 and R_2 can be 100Ω . This can also be accomplished by removing R_1 and making R_2 50Ω .

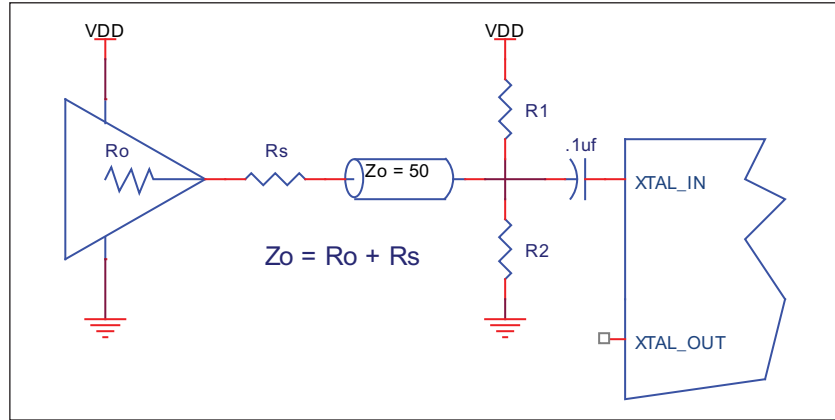

FIGURE 3. GENERAL DIAGRAM FOR LVC MOS DRIVER TO XTAL INPUT INTERFACE

APPLICATION SCHEMATIC

Figure 4A shows a schematic example of the 840011. An example of LVCMOS termination is shown in this schematic. Additional LVCMOS termination approaches are shown in the LVCMOS Termination Application Note. In this example, an 18pF parallel resonant

26.5625MHz crystal is used for generating 106.25MHz output frequency. The C1 = 27pF and C2pF = 33pF are recommended for frequency accuracy. For different board layout, the C1 and C2 values may be slightly adjusted for optimizing frequency accuracy.

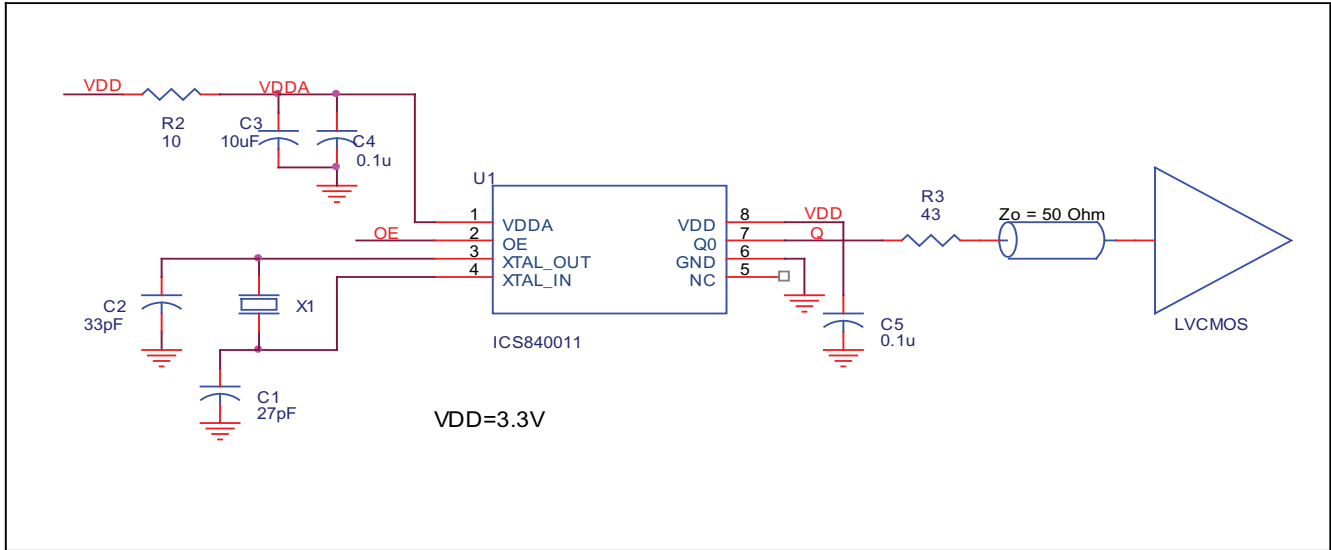

FIGURE 4A. 840011 SCHEMATIC EXAMPLE

PC BOARD LAYOUT EXAMPLE

Figure 4B shows an example of 840011 P.C. board layout. The crystal X1 footprint in this example allows either surface mount (HC49S) or through hole (HC49) package. C3 is 0805.

C1 and C2 are 0402. Other resistors and capacitors are 0603. This layout assumes that the board has clean analog power and ground planes.

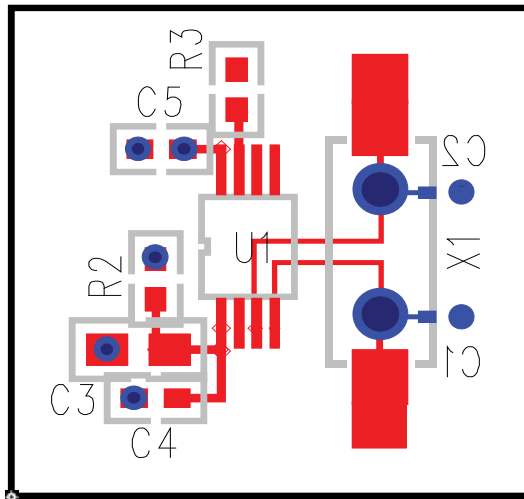

FIGURE 4B. 840011 PC BOARD LAYOUT EXAMPLE

RELIABILITY INFORMATION

TABLE 7. θ_{JA} VS. AIR FLOW TABLE FOR 8 LEAD TSSOP

θ_{JA} by Velocity (Meters per Second)			
	0	1	2.5
Multi-Layer PCB, JEDEC Standard Test Boards	101.7°C/W	90.5°C/W	89.8°C/W

TRANSISTOR COUNT

The transistor count for 840011 is: 1521

PACKAGE OUTLINE - G SUFFIX FOR 8 LEAD TSSOP

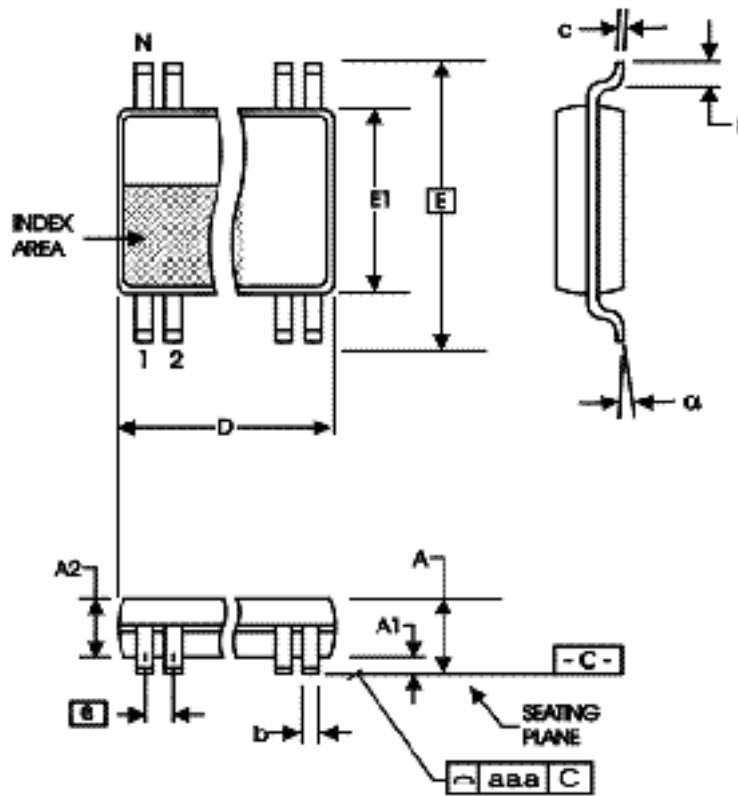

TABLE 8. PACKAGE DIMENSIONS

SYMBOL	Millimeters	
	Minimum	Maximum
N	8	
A	--	1.20
A1	0.05	0.15
A2	0.80	1.05
b	0.19	0.30
c	0.09	0.20
D	2.90	3.10
E	6.40 BASIC	
E1	4.30	4.50
e	0.65 BASIC	
L	0.45	0.75
α	0°	8°
aaa	--	0.10

Reference Document: JEDEC Publication 95, MO-153

TABLE 9. ORDERING INFORMATION

Part/Order Number	Marking	Package	Shipping Packaging	Temperature
ICS840011AGLN	011AN	8 lead "Lead Free Annealed" TSSOP	tube	-30°C to 85°C
ICS840011AGLNT	011AN	8 lead "Lead Free Annealed" TSSOP	tape & reel	-30°C to 85°C

NOTE: Parts that are ordered with an "LF" suffix to the part number are the Pb-Free configuration and are RoHS compliant.

REVISION HISTORY SHEET				
Rev	Table	Page	Description of Change	Date
A	T9	10	Ordering Information Table - corrected count from 154 per tube to 100.	10/15/04
A	T9	7 11	Added <i>LVC MOS to XTAL Interface</i> , Ordering Information Table - deleted quantity from tube count. Updated datasheet format.	1/22/07
A	T9	11	Ordering Information Table - removed leaded devices. Updated data sheet format.	9/1/15
A			Product Discontinuation Notice - Last time buy expires May 6, 2017. PDN CQ-16-01	5/20/16

**Corporate Headquarters**

6024 Silver Creek Valley Road
San Jose, California 95138

Sales

800-345-7015 or +408-284-8200
Fax: 408-284-2775
www.IDT.com

Technical Support

email: clocks@idt.com

DISCLAIMER Integrated Device Technology, Inc. (IDT) and its subsidiaries reserve the right to modify the products and/or specifications described herein at any time and at IDT's sole discretion. All information in this document, including descriptions of product features and performance, is subject to change without notice. Performance specifications and the operating parameters of the described products are determined in the independent state and are not guaranteed to perform the same way when installed in customer products. The information contained herein is provided without representation or warranty of any kind, whether express or implied, including, but not limited to, the suitability of IDT's products for any particular purpose, an implied warranty of merchantability, or non-infringement of the intellectual property rights of others. This document is presented only as a guide and does not convey any license under intellectual property rights of IDT or any third parties.

IDT's products are not intended for use in applications involving extreme environmental conditions or in life support systems or similar devices where the failure or malfunction of an IDT product can be reasonably expected to significantly affect the health or safety of users. Anyone using an IDT product in such a manner does so at their own risk, absent an express, written agreement by IDT.

Integrated Device Technology, IDT and the IDT logo are registered trademarks of IDT. Other trademarks and service marks used herein, including protected names, logos and designs, are the property of IDT or their respective third party owners.

Copyright 2016. All rights reserved.