

PART NUMBER	NO. OF CKTS	DIM A	DIM B	DIM C	DIM D
91816-0008	8	17.78	7.62	15.24	14.73
91816-0010	10	20.32	10.16	17.78	17.27
91816-0012	12	22.86	12.70	20.32	19.81
91816-0014	14	25.40	15.24	22.86	22.35
91816-0016	16	27.94	17.78	25.40	24.89
91816-0020	20	33.02	22.86	30.48	29.97
91816-0024	24	38.10	27.94	35.56	35.05
91816-0026	26	40.64	30.48	38.10	37.59
91816-0030	30	45.72	35.56	43.18	42.67
91816-0034	34	50.80	40.64	48.26	47.75
91816-0040	40	58.42	48.26	55.88	55.37

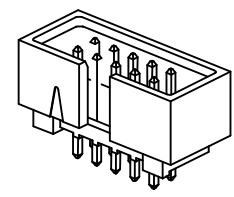
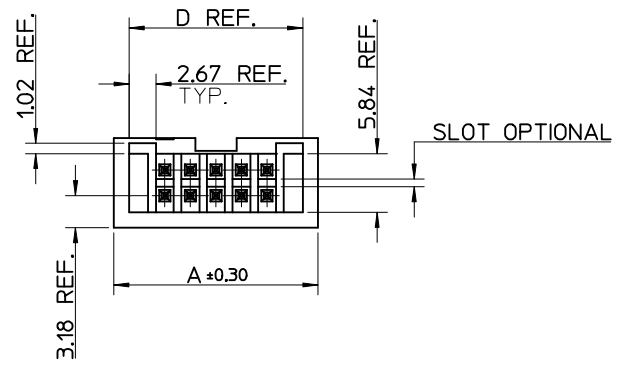
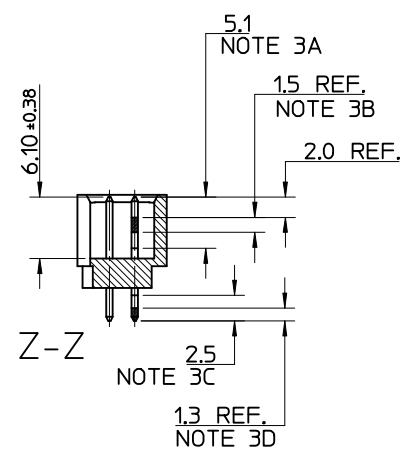
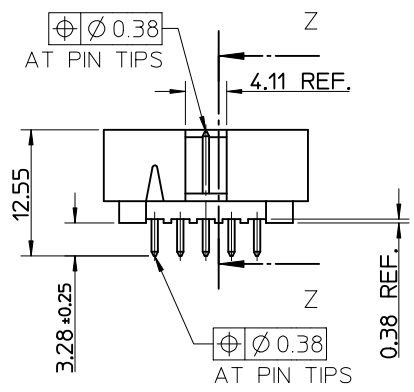
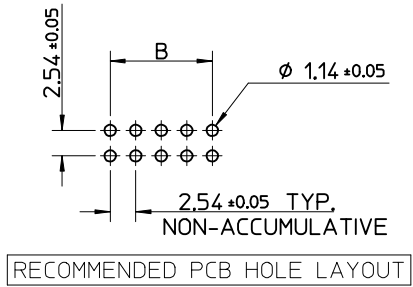
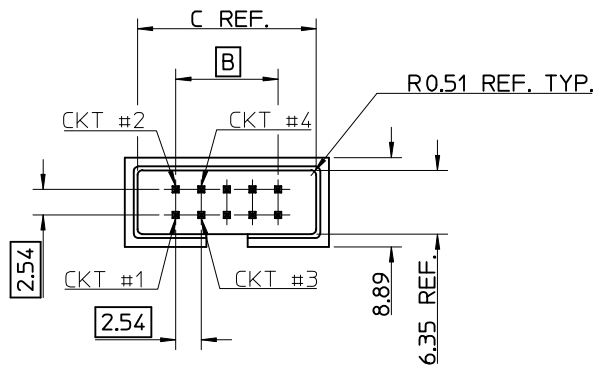

- NOTES:
- MATERIALS:
HOUSING: PCT, 30% GLASS FILLED, UL94 V-0, COLOUR BLACK.
PIN: BRASS, 0.64mm SQUARE REF.
 - PLATING:
CONTACT AREA: 0.38um GOLD MIN. OVER 1.27um NICKEL MIN.
SOLDER AREA: 1.9um TIN MIN. OVER 1.27um NICKEL MIN.
 - DIMENSIONS FOR PLATING LOCATIONS:
3A: MINIMUM COVERAGE OF GOLD PLATING (CONTACT AREA).
3B: THICKNESS AND POROSITY MEASURING ZONE FOR GOLD.
3C: MINIMUM COVERAGE OF TIN PLATING (SOLDER AREA).
3D: THICKNESS MEASURING ZONE FOR TIN.
 - CONFORMS TO PRODUCT SPECIFICATION PS-91816-001.
 - PACKAGING SPECIFICATION :
TRAY : PK-87835-001
 - COLOUR VARIATION MAY BE VISIBLE ON HOUSING SURFACES.

UPDATE NOTE 5. EC NO: S2016-0050 DRWN:ATSEE 2015/07/13 CHYKD:CGOH 2015/09/22 APPR:KHLIM 2015/09/22	QUALITY SYMBOLS ▽=0 ▽=0	GENERAL TOLERANCES (UNLESS SPECIFIED)		DIMENSION STYLE MM ONLY	SCALE 2:1	DESIGN UNITS METRIC	THIRD ANGLE PROJECTION		
		4 PLACES ± --- ± --- 3 PLACES ± --- ± --- 2 PLACES ± 0.2 ± --- 1 PLACE ± 0.3 ± ---	mm INCH	DRAWN BY JDENEHY	DATE 2007/01/22	TITLE C-GRID SHROUDED HEADER SLOTTED W/O STANDOFFS ROHS COMPATIBLE			
		ANGULAR ± 2 °		CHECKED BY DWASZKIEWICZ	DATE 2007/01/23	MOLEX INCORPORATED			
		DRAFT WHERE APPLICABLE MUST REMAIN WITHIN DIMENSIONS		APPROVED BY JDENEHY	DATE 2007/01/23	MATERIAL NO. SEE CHART	DOCUMENT NO. SD-91816-001	SHEET NO. 1 OF 1	