



- IEC 62638 and IEC 60950 I.T.E. Safety
- Medical IEC 60601-1-1 3rd Ed, Amend 1 Safety
- EN 60601-1-2 4th Edition EMC
- BF Leakage, 2 MOPP
- 55011 (CISPR11) Class B Emissions
- Universal 80-275 VAC Input, 50/60 Hz
- Open Frame PCB Mount; Encapsulated PCB, DIN Rail and Chassis Mount Options
- No Load Power Consumption < 100 mW



PRODUCT DESCRIPTION

The Astrodyne TDI EPM15 series of Open Frame or Encapsulated Switching Power Supplies are designed for medical and industrial applications. These products operate over the input voltage range of 80 to 275 VAC and 50/60Hz frequency and produce up to 15 Watts of regulated DC output. They are compliant with IEC 60601-1-1, 3rd Edition, Amendment 1 safety and IEC 60601-1-2, 4th Edition, Class B EMC standards, for use across a wide variety of medical applications, including those within the home.

PRODUCT MODELS

Model	Output Power *		Output Voltage	Output Current *		Load Regulation
	Natural Convection/Forced Open Frame or Encapsulated			Natural Convection/Forced Open Frame or Encapsulated		
Open Frame PCB Mount Models						
EPM15-033-BP-0F0	7.5W/10W		3.3VDC	2.3A/3.0A		±1.0%
EPM15-050-BP-0F0	12W/15W		5VDC	2.4A/3.0A		±1.0%
EPM15-090-BP-0F0	12W/15W		9VDC	1.33/1.67A		±0.5%
EPM15-120-BP-0F0	12W/15W		12VDC	1.0A/1.25A		±0.5%
EPM15-150-BP-0F0	12W/15W		15VDC	0.8A/1.0A		±0.5%
EPM15-180-BP-0F0	12W/15W		18VDC	0.67A/0.83A		±0.5%
EPM15-240-BP-0F0	12W/15W		24VDC	0.5A/0.63A		±0.5%

15 Watt Medical/Industrial Grade Power Supply

EPM15

* The maximum output power for an Open Frame model is limited to 7.5 Watts at 3.3V or 12W at $\geq 5V$ if it runs in a non-ventilated environment or 10 Watts at 3.3V or 15 Watts at $\geq 5V$ if it runs in a minimally ventilated environment (airflow ≥ 6 CFM with 100mm distance to the unit.)

Model	Output Power	Output Voltage	Output Current	Load Regulation
Encapsulated Chassis Mount Models				
EPM15-033-BC-0F0	10W	3.3VDC	3.0A	$\pm 1.0\%$
EPM15-050-BC-0F0	15W	5VDC	3.0A	$\pm 1.0\%$
EPM15-090-BC-0F0	15W	9VDC	31.67A	$\pm 0.5\%$
EPM15-120-BC-0F0	15W	12VDC	1.25A	$\pm 0.5\%$
EPM15-150-BC-0F0	15W	15VDC	1.0A	$\pm 0.5\%$
EPM15-180-BC-0F0	15W	18VDC	0.83A	$\pm 0.5\%$
EPM15-240-BC-0F0	15W	24VDC	0.63A	$\pm 0.5\%$
Encapsulated PCB Mount Models				
EPM15-033-BE-0F0	10W	3.3VDC	3.0A	$\pm 1.0\%$
EPM15-050-BE-0F0	15W	5VDC	3.0A	$\pm 1.0\%$
EPM15-090-BE-0F0	15W	9VDC	31.67A	$\pm 0.5\%$
EPM15-120-BE-0F0	15W	12VDC	1.25A	$\pm 0.5\%$
EPM15-150-BE-0F0	15W	15VDC	1.0A	$\pm 0.5\%$
EPM15-180-BE-0F0	15W	18VDC	0.83A	$\pm 0.5\%$
EPM15-240-BE-0F0	15W	24VDC	0.63A	$\pm 0.5\%$
Encapsulated DIN Rail Mount Models				
EPM15-033-BD-0F0	10W	3.3VDC	3.0A	$\pm 1.0\%$
EPM15-050-BD-0F0	15W	5VDC	3.0A	$\pm 1.0\%$
EPM15-090-BD-0F0	15W	9VDC	31.67A	$\pm 0.5\%$
EPM15-120-BD-0F0	15W	12VDC	1.25A	$\pm 0.5\%$
EPM15-150-BD-0F0	15W	15VDC	1.0A	$\pm 0.5\%$
EPM15-180-BD-0F0	15W	18VDC	0.83A	$\pm 0.5\%$
EPM15-240-BD-0F0	15W	24VDC	0.63A	$\pm 0.5\%$

INPUT SPECIFICATIONS

Input Voltage Range	100-250VAC rated 80-275VAC tested
Input Frequency	47-63 Hz (50/60 Hz nom.)
Input Current (rated)	0.5A max at 100VAC 0.25A max at 240VAC
Leakage Current	100uA max at 240VAC 50Hz
No Load Power	100mW max

MAIN OUTPUT SPECIFICATIONS

Output Voltage	See selection chart
Output Power	15W max
Load Regulation	±1% max, see selection chart
Line Regulation	±0.2% max
Efficiency	> 70% typ
Over Voltage Protection*	112-132% Vout, hiccup mode
Over Load Protection*	110 to 150% x Rated Power, Auto Recovery
Short Circuit Protection	Auto Recovery
Temperature Coefficient	±0.04%/°C
Hold-up Time, full load	100ms typ, 230VAC 20ms typ, 115VAC
Ripple/Noise	100mV Pk-Pk max, 3.3V-12V 150mV Pk-Pk max, 15V-24V

ISOLATION SPECIFICATIONS

Input to Output	4000 VAC, 2 MOPP
Isolation Resistance	50 MΩ

MECHANICAL SPECIFICATIONS **

Size	2.46" x 1.66" x 0.91" 62.5 x 42.2 x 23 mm
Weight	38g / 1.34oz, 125g/4.4oz, 233g/8.12oz
Package Types	Open Frame, Encapsulated, Chassis

** Mechanical specifications are for Open Frame package type. Refer to Outline Drawings for other package types.

All Specifications are typical at nominal input, full load, 25°C unless specified otherwise.

SAFETY AND COMPLIANCE CERTIFICATIONS

Safety Approvals	IEC 60601-1 3 rd Ed, Amend 1; IEC 62368-1; IEC 60950-1; CSA C22.2; CB Scheme
EMC Overall	EN60601-1-2, 4 th Ed, Class B
Conducted and Radiated Emissions	EN 55011 (CISPR11), Class B
Harmonic Current	EN 61000-3-2
Voltage Fluctuations	EN 61000-3-3
ESD Immunity	EN 61000-4-2, Level 4
RF Field Immunity	EN 61000-4-3, Level 3
EFT Burst Immunity	EN 61000-4-4, Level 3
Surge Immunity	EN 61000-4-5, Level 3
Conducted Immunity	EN 61000-4-6, Level 3
Magnet Field Immunity	EN 61000-4-8, Level 4
Voltage Dips and Interruptions	EN 61000-4-11

ENVIRONMENTAL SPECIFICATIONS

Operating Temperature	-20 to +40°C at Full Load, -40 to -20°C and +40 to +70°C with Derating (see charts)
Cooling	Free Air Convection
Storage Temperature*	-40 to +85°C
Operating Humidity*	0% to 95%, non-condensing
Operating Altitude	3000m max

* These are stress ratings. Exposure of the devices to any of these conditions may adversely affect long term reliability. Operation under conditions other than the standard operating conditions is neither warranted nor implied.

TEMPERATURE DERATING

Encapsulated Models with Natural Convection

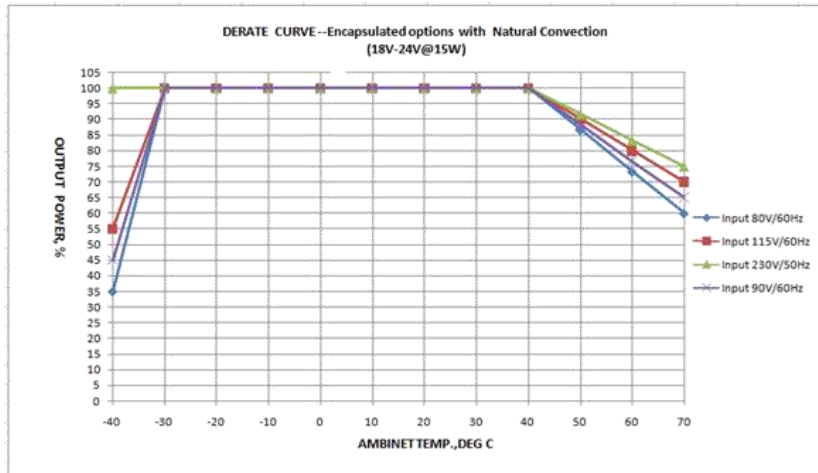
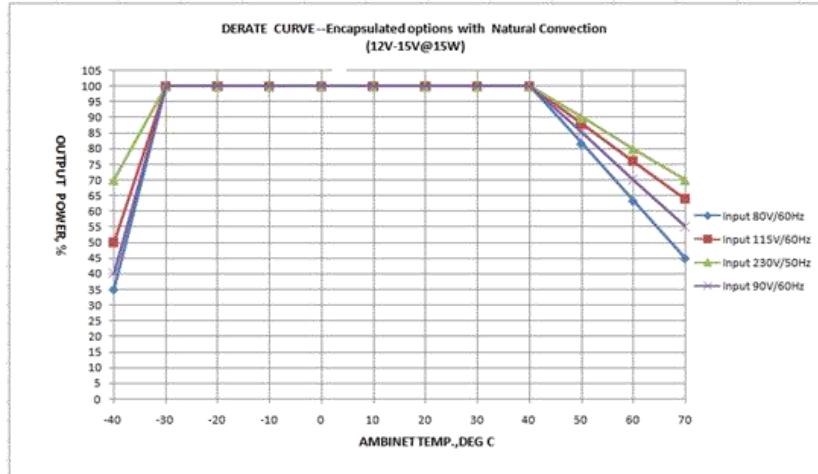
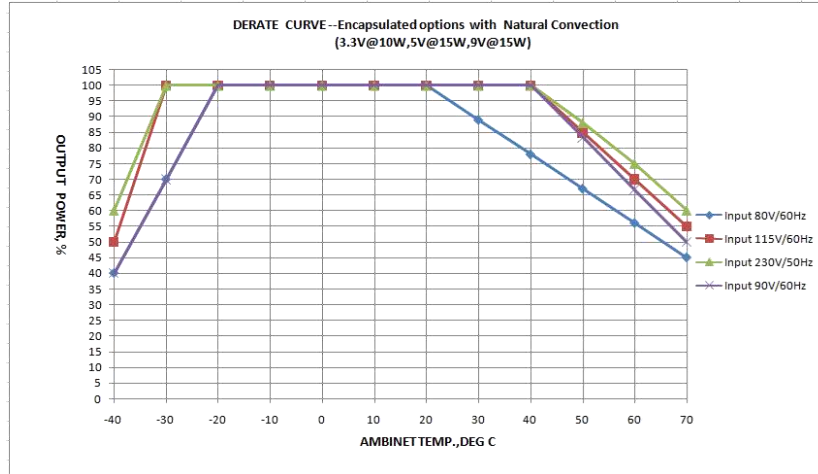

Open Frame Models with Natural Convection

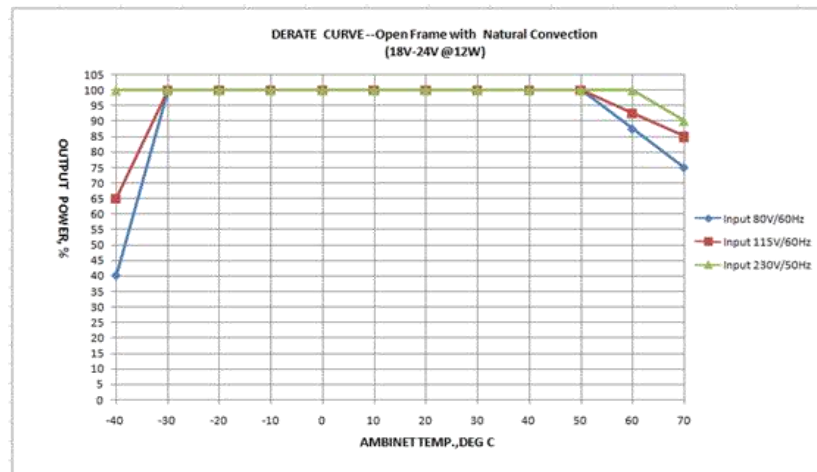
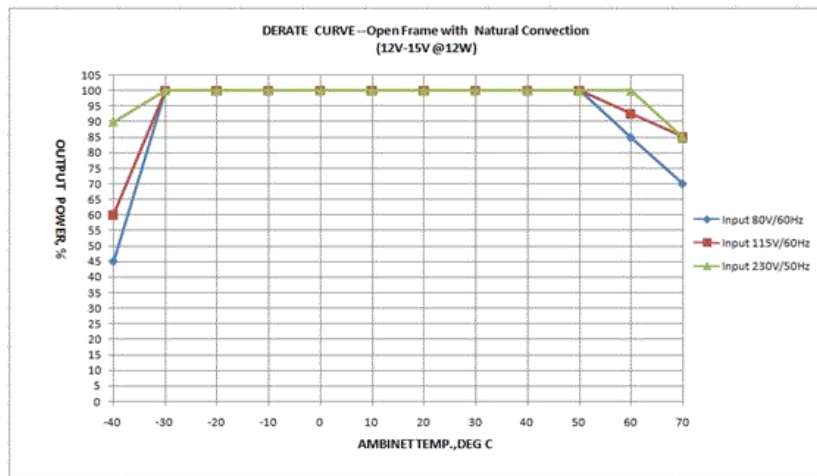
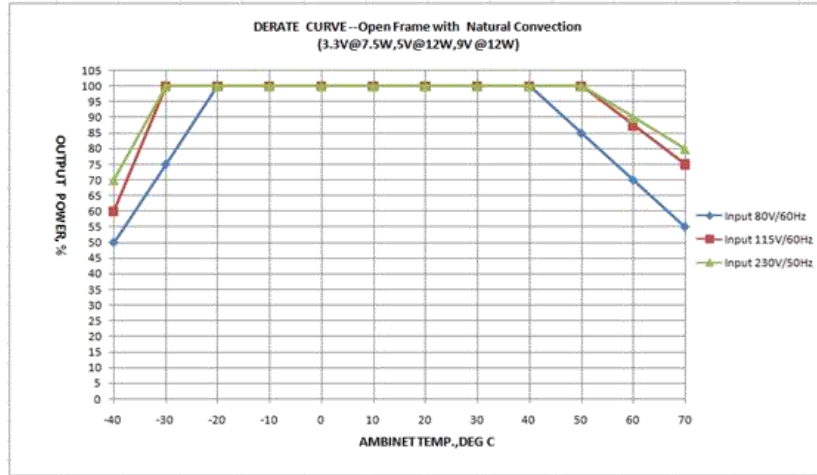

Open Frame Models with Forced Air Convection

(airflow \geq 6 CFM with 100mm distance to unit)

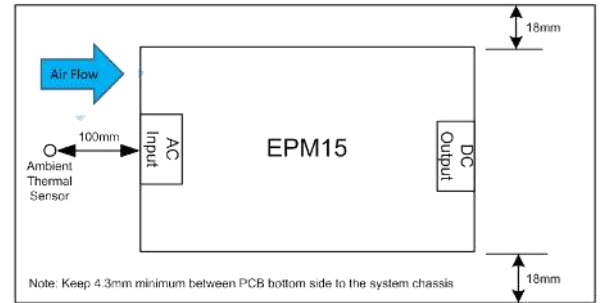
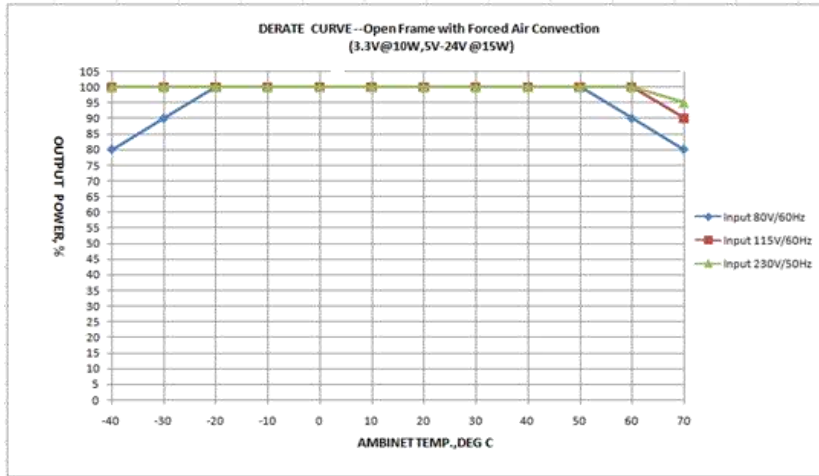

Note: For all temperature derate curves, the output power at low temperature is just for cold start.

OUTLINE DRAWINGS

Encapsulated Chassis Mount – EPM15-xxx-BC-0F0

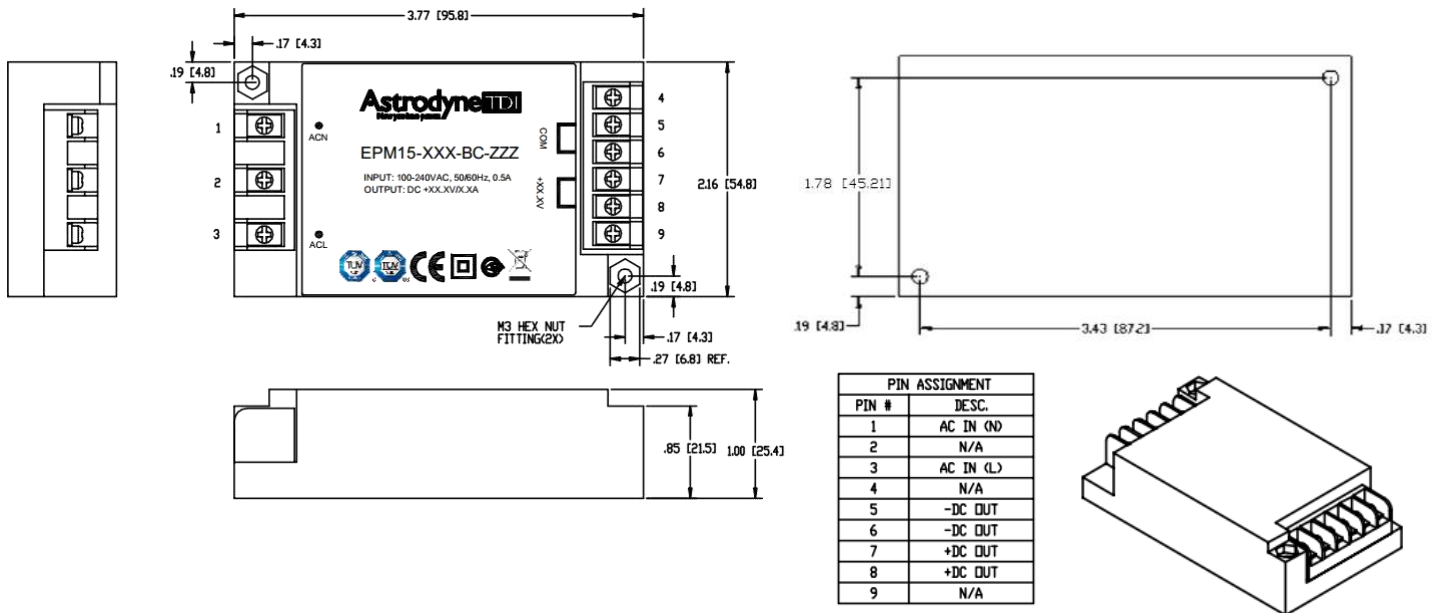

Encapsulated DIN Rail Mount – EPM15-xxx-BD-0F0

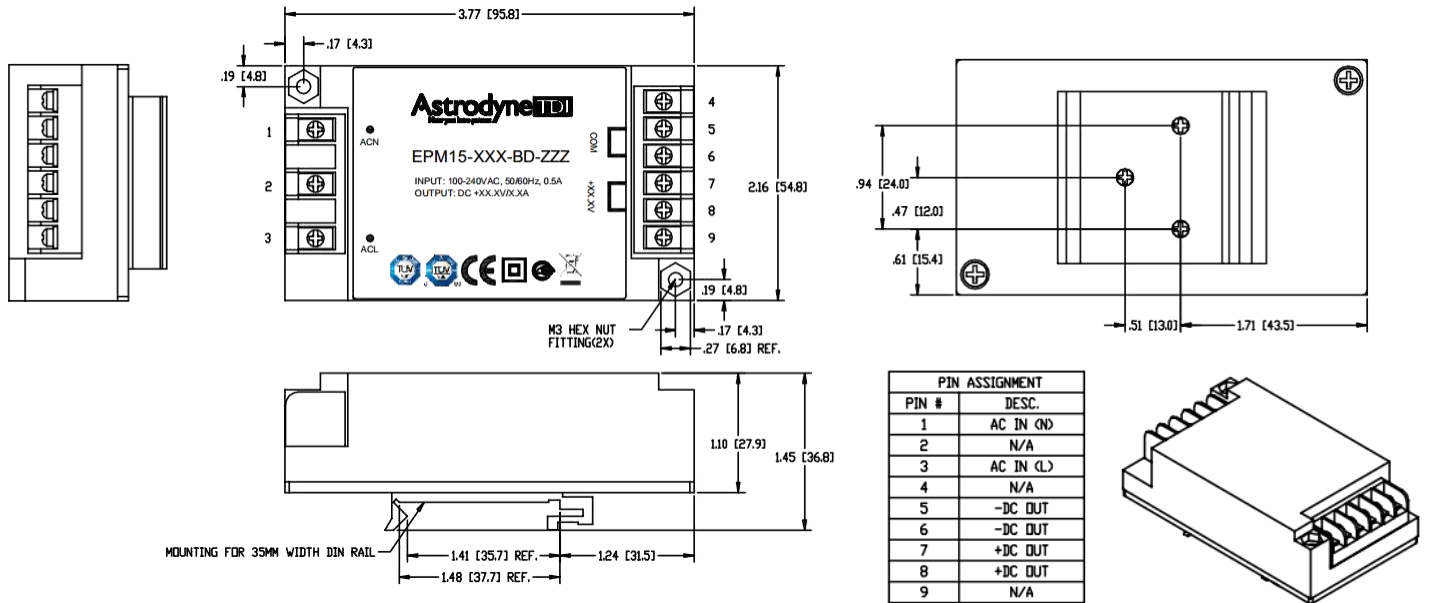

Encapsulated PCB Mount – EPM15-xxx-BE-0F0

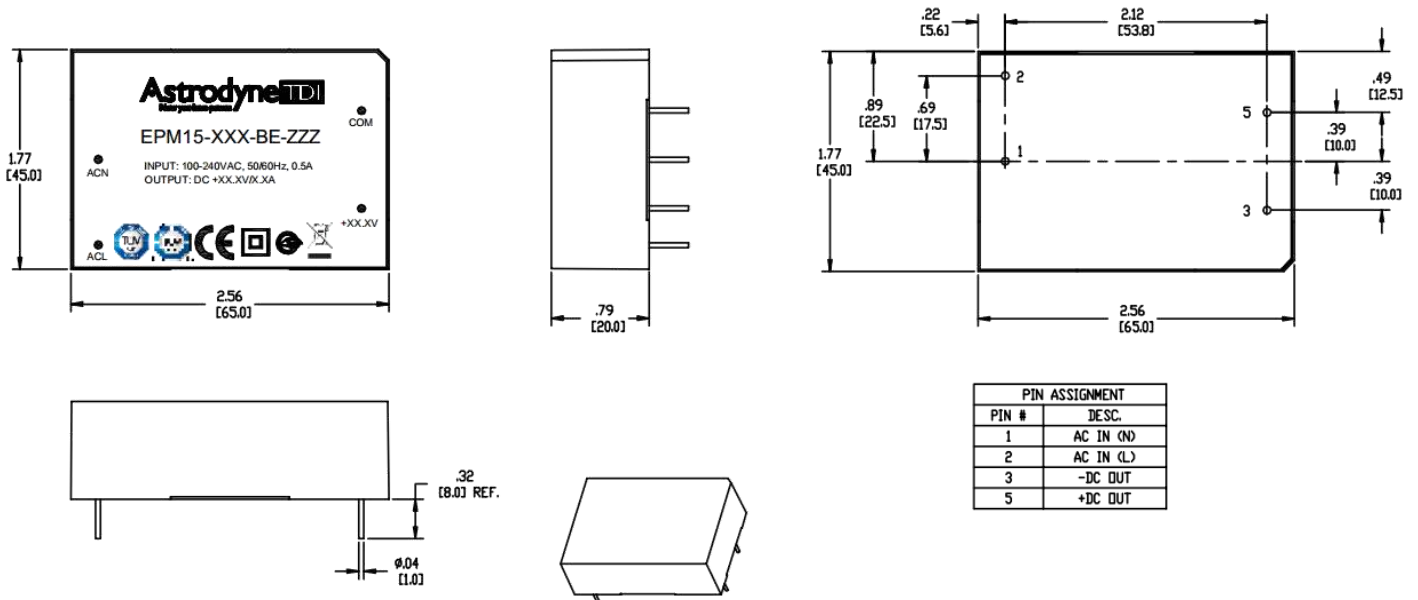

Open Frame PCB Mount – EPM15-xxx-BP-0F0

