

PART NUMBER	REVISION	DESCRIPTION	FEED TYPE
2151181-1	C	FINE CRIMP HEIGHT ADJUST	MECHANICAL
2151181-2	D	FINE CRIMP HEIGHT ADJUST	PNEUMATIC
5-2151181-1	C	SEAL STRIPPER CRIMPER TERMINATING UNIT	MECHANICAL
5-2151181-2	D	SEAL STRIPPER CRIMPER TERMINATING UNIT	PNEUMATIC
7-2151181-1	C	MECHANICAL AND CRIMP TOOLING KIT	MECHANICAL
7-2151181-2	D	PNEUMATIC AND CRIMP TOOLING KIT	PNEUMATIC
7-2151181-7	B	CRIMP TOOLING KIT	-

ATLANTIC VERSION TERMINATOR INTERFACE ADAPTER

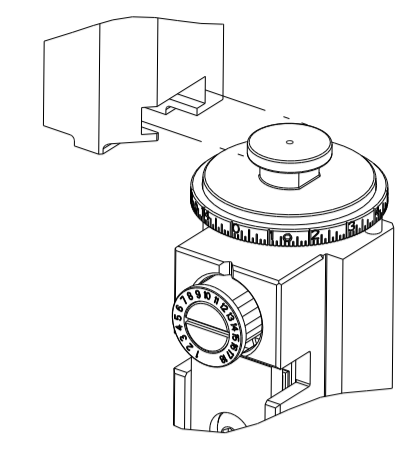

APPLICATOR DATA		
CRIMP	SIZE	TYPE
WIRE	2.03 mm [.080]	F
INSUL	4.06 mm [.160]	O

APPLICATOR INSTRUCTIONS 408-35042

TERMINAL DATA: TE TERMINAL		TE CRIMP SPECIFICATION	
TERMINAL NAME: TAB 2.8 x 0.8			
WIRE STRIP LENGTH		INSULATION DIAMETER RANGE	
4.20-4.80 mm [.165-.189 IN]		Ø0.00-3.40 mm [.000-.134 IN]	
TERMINAL APPLICATION SPECIFICATION	114-18051		
TERMINALS APPLIED			
TE TERMINAL	TE TERMINAL	TE SEAL	TE SEAL
1-962915-1	2-962915-1		828904-1
1-962915-2	2-962915-2		828904-2
1-962915-3	2-962915-3		828904-3
	6-962915-6		

TERMINAL DATA: TE TERMINAL		TE CRIMP SPECIFICATION	
TERMINAL NAME: TAB 2.8 X 0.8			
WIRE STRIP LENGTH		INSULATION DIAMETER RANGE	
4.20-4.80 mm [.165-.189 IN]		Ø 3.40 mm [.134 IN] MAX	
TERMINAL APPLICATION SPECIFICATION			
TERMINALS APPLIED			
TE TERMINAL	TE TERMINAL	TE SEAL	TE SEAL
1-962915-3			828904-1
			828904-2
			828904-3

WIRE SIZE	CRIMP HEIGHT mm [INCH]	CRIMP HEIGHT REFERENCE SETTING
1.00mm2	1.20+/-0.05 [.047+/- .002]	5.4
0.75mm2	1.18+/-0.05 [.046+/- .002]	5.6
0.50mm2	1.15+/-0.05 [.045+/- .002]	5.9

WIRE SIZE	CRIMP HEIGHT mm [INCH]	CRIMP HEIGHT REFERENCE SETTING
0.61mm2	1.18+/-0.03 [.046+/- .001]	6.2

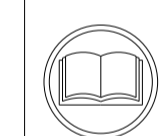

- 1. RECOMMENDED SPARE PARTS
- 2. REFER TO SUPPLIED INSTRUCTION SHEET FOR CLEANING, LUBRICATION AND STORAGE OF APPLICATOR.
- 3. APPLY PART NUMBER 1-23419-5 LOCTITE TO THREADS OF ITEMS 180. APPLY PART NUMBER 2-23419-6 LOCTITE TO THREADS OF ITEM 242.
- 4. CRIMP HEIGHT REFERENCE SETTING WAS THE SETTING USED WHEN THE APPLICATOR WAS QUALIFIED AT THE FACTORY. ADJUSTMENT MAY BE NECESSARY WHEN RUNNING APPLICATOR IN THE FIELD.
- 5. APPLY TORQ-SEAL IN ALLEN SOCKET TO FILL HOLE AFTER FLAT HD HAS BEEN ADJUSTED TO CORRECT HEIGHT AT QUALIFICATION. APPLY #1-23419-5 LOC-TITE TO THREADS.
- 6. THIS CRIMP PARAMETER IS PROVIDED TO MEET A CUSTOM AND UNIQUE CUSTOMER REQUIREMENT. IT HAS BEEN EVALUATED AND IS CONDITIONALLY SPECIFIED BY TE CONNECTIVITY. THIS CUSTOMIZED CRIMP PARAMETER IS NOT LISTED AS AN APPROVED APPLICATION WITHIN A TE CONNECTIVITY APPLICATION SPECIFICATION; HOWEVER, IT HAS BEEN VALIDATED ACCORDING TO TE CONNECTIVITY SPECIFICATION 109-18079 (TEST GROUP 1) AND 114-18022. TE CONNECTIVITY EXPRESSLY DISCLAIMS ANY AND ALL WARRANTIES THAT THE PRODUCT WILL PERFORM SIMILARLY TO VALIDATED AND APPROVED APPLICATIONS, AS STATED WITHIN TE CONNECTIVITY APPLICATION SPECIFICATIONS, INCLUDING BUT NOT LIMITED TO IMPLIED WARRANTIES OF MERCHANTABILITY OR FITNESS FOR PARTICULAR PURPOSE. AS SUCH, IT IS HIGHLY RECOMMENDED THAT THE CUSTOMER PERFORM FURTHER DETAILED EVALUATION TO ASSESS PRODUCT PERFORMANCE IN THE SPECIFIC APPLICATION.
- 7. UNLESS SPECIFIED OTHERWISE TORQUE VALUES SHALL BE USED PER DOCUMENT, 101-35000.

***WARNING**
 ON INSTALLATION, SET WIRE DISC TO CRIMP HEIGHT REFERENCE SETTING FOR LARGEST WIRE SIZE. CRIMP HEIGHT REFERENCE SETTINGS GREATER THAN THE VALUE SHOWN MAY CAUSE DAMAGE TO THE CRIMP TOOLING, REFER TO THE INSTRUCTION SHEET FOR PROPER SETUP AND ADJUSTMENTS.

LOC	DIST	REVISIONS					
A	66	P	LTN	DESCRIPTION	DATE	OWN	APVD
		B		ECR-17-016225	03NOV2017	JAH	CT
		C		ECR-18-006599	30APR2018	JAH	JDG
		D		ECR-19-005973	12APR2019	JAH	CT
		D1		ECR-22-147638	28JUL2022	FJ	YY

-	-	-	1	1	-	-	1803515-3	RAM ASSEMBLY, SF ATLANTIC	293
-	-	-	1	1	-	-	2-1803583-1	APPLICATOR BASIC ASSEMBLY, SF	292
-	1	-	1	-	1	-	2119641-1	FEED CAM, AIR FEED	248
-	1	1	1	1	1	1	2119082-9	CAM, SNAIL, INSULATION ADJUSTMENT	244
-	1	1	1	1	1	1	2079764-1	WASHER, WAVE SPRING, CREST-TO-CREST	243
-	1	1	1	1	1	1	2119083-1	RETAINER, INSULATION DIAL	242
-	1	1	1	1	1	1	7-18023-7	SCR, SKT HD CAP M3 X 4.0	241
-	-	1	-	1	-	1	2119580-1	MECHANICAL FEED ASSEMBLY	239
-	1	-	1	-	1	-	2844940-1	AIR FEED MODULE	238
-	-	-	1	1	-	-	4-1722335-3	STRIPPER, SIDE FEED	182
-	-	-	1	1	-	-	1-5018030-0	NUT, HEX, REG, RoHS, M3.5	181
-	-	-	1	1	-	-	2-1752354-3	STANDOFF, HOLD-DOWN	180
-	-	-	1	1	-	-	993111-1	PIN, SLOTTED SPRING 3.0 X 20.0	177
-	-	-	1	1	-	-	5-22280-0	SPRING, COMPRESSION	176
-	-	-	1	1	-	-	1752353-3	GUIDE PIN, HOLDDOWN	175
-	-	-	1	1	-	-	1901680-2	GUIDE PIN, HOLDDOWN	174
-	REF	REF	REF	REF	REF	REF	994970-2	COUNTER, MAGNETIC	164
-	1	1	1	1	1	1	2844908-1	SCREW, LOCKING	99
-	1	1	1	1	1	1	2844907-1	POST, LOCKING	98
-	1	1	1	1	1	1	455888-4	SPACER, CRIMPER	82
-	1	1	1	1	1	1	1803607-3	DOCUMENTATION PACKAGE	71
-	1	1	1	1	1	1	2119791-9	DEPRESSOR, WIRE	70
-	1	1	1	1	1	1	2119943-1	WASHER, SPACER	69
-	1	1	1	1	1	1	2119740-1	TAG, IDENTIFICATION	67
-	2	2	2	2	2	2	2168078-1	SCREW, DRIVE, RH, RoHS, 2 x .188	66
-	1	1	1	1	1	1	2168083-2	SCR, SKT HD CAP, RoHS, M4 X 8.0	60
-	1	1	1	1	1	1	5-18022-5	SCR, HEX HD CAP, M4 X 6.0	59
-	1	1	1	1	1	1	985575-3	SCR, FLT SKT HD CAP M3 X 10.0	57
-	1	1	1	1	1	1	1338685-1	PAWL, FEED	56
-	4	4	4	4	4	4	2168083-3	SCR, SKT HD CAP, RoHS, M4 X 12.0	54
-	2	2	2	2	2	2	2-2168083-5	SCR, SKT HD CAP, RoHS, M4 X 14	53
-	1	1	1	1	1	1	1803382-6	HOLD DOWN, SPRING LOADED	50
-	1	2	1	2	1	2	18023-9	SCR, SKT HD CAP M4 X 6.0	49
-	-	1	-	1	-	1	2119652-1	FEED CAM, PRE FEED	48
-	-	1	-	1	-	1	2119653-1	FEED CAM, POST FEED	47
-	1	1	-	-	1	1	1803583-9	APPLICATOR BASIC ASSEMBLY, SF	46
-	1	1	-	-	1	1	1803515-1	RAM ASSEMBLY, SF ATLANTIC	44
-	1	1	1	1	1	1	1803602-1	SCR, BHSC, RoHS (M8 X 25)	41
-	1	1	1	1	1	1	1-1752356-6	SUPPORT, TERMINAL	34
-	2	2	2	2	2	2	2079383-5	SCR, BHSC, RoHS (M4 X 20)	33
-	2	2	2	2	2	2	3-2844962-0	SPACER, CYLINDRICAL, STRIP GUIDE	30
-	1	1	1	1	1	1	2844992-2	ASSEMBLY, STRIP GUIDE	29
-	1	1	1	1	1	1	455888-3	SPACER, CRIMPER	28
-	1	1	1	1	1	1	1320928-6	STRIP GUIDE	24
-	1	1	-	-	1	1	2168083-2	SCR, SKT HD CAP, RoHS, M4 X 8.0	21
-	2	2	1	1	2	2	1-18028-2	WASHER, FLAT, REG M4	20
-	1	1	-	-	1	1	2119533-1	STRIPPER, SIDE FEED	19
-	1	1	1	1	1	1	2119806-1	INSERT, SHEAR	13
-	1	1	1	1	1	1	3-22280-3	SPRING, COMPRESSION	12
-	1	1	1	1	1	1	1-356885-4	STOP, SHEAR	11
-	1	1	1	1	1	1	2119805-1	SHEAR HOLDER, FRONT	10
-	1	1	1	1	1	1	318707-1	FLOATING SHEAR, FRONT	9
1	2	2	1	1	1	1	1-1803554-4	ANVIL, COMBINATION	8
-	1	1	1	1	1	1	240641-5	SPACER	7
-	1	1	1	1	1	1	2119781-1	DEPRESSOR, SHEAR	5
-	1	1	1	1	1	1	238011-7	BLOCK, CRIMPER SPACER	4
1	2	2	1	1	1	1	1-1633965-8	CRIMPER, INSULATION O PREMIUM	3
-	1	1	1	1	1	1	1-455888-1	SPACER, CRIMPER	2
1	2	2	1	1	1	1	1-456405-6	CRIMPER, WIRE PREMIUM	1

ITEM NO	PART NO	DESCRIPTION	ITEM NO
-77	-72	-71	-52
-51	-2	-1	
OWN		05AUG2011	
CHK		05AUG2011	
APVD		05AUG2011	
S. XI			
PRODUCT SPEC			
APPLICATION SPEC			
MATERIAL			
FINISH			
WEIGHT			
SCALE		1:2	
SHEET		1	OF 4
REV		D1	

ATLANTIC VERSION
 Shown on sheets 1 of 4 & 2 of 4
 (Pacific version shown on sheets 3 of 4 & 4 of 4)

LOC	DIST	REV	DATE	BY	APPV
A	66				

FEED TYPE MECHANICAL

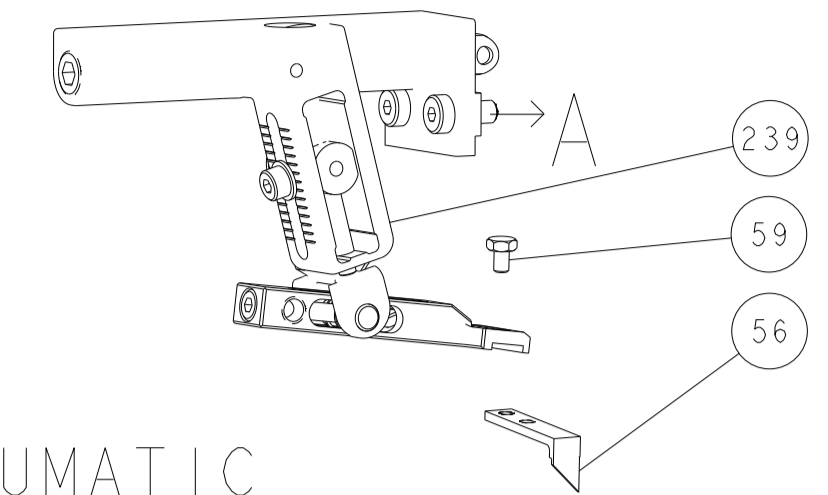

PNEUMATIC

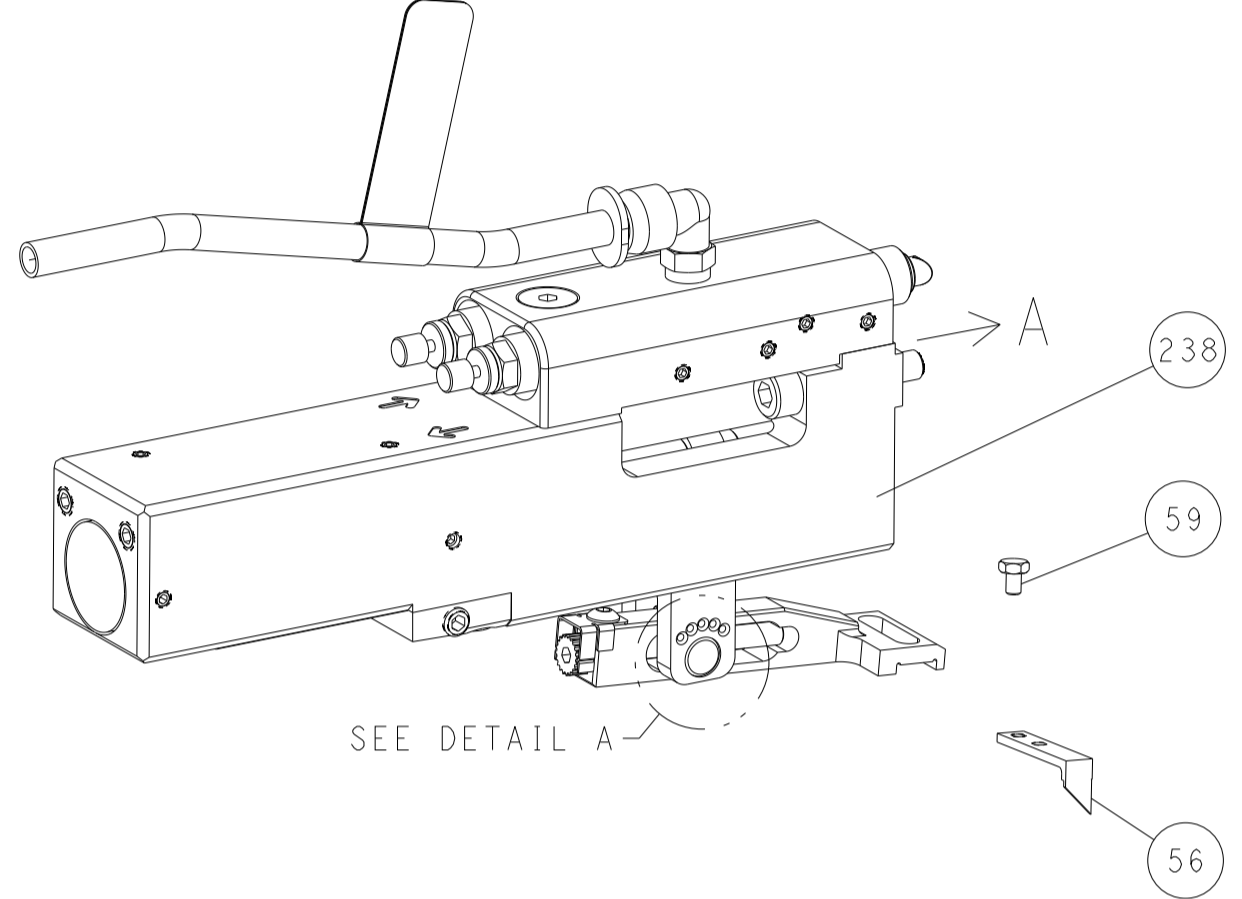

FEED SPRING SETTING POSITION (SHOWN FROM REAR SIDE)



DETAIL A

CAM POSITIONS

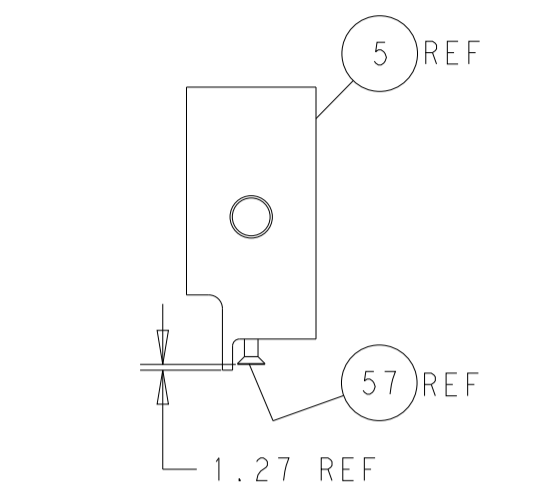
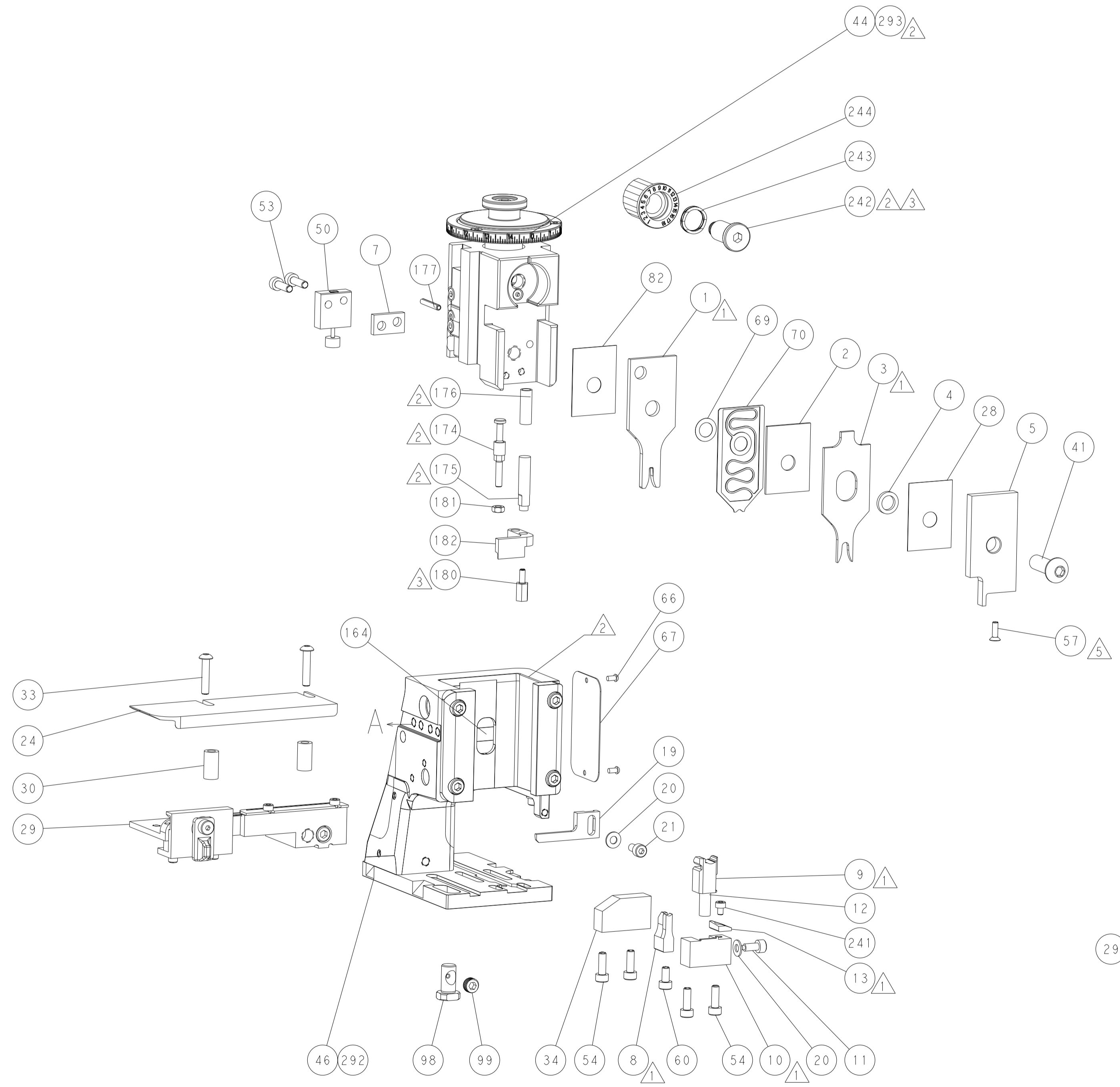
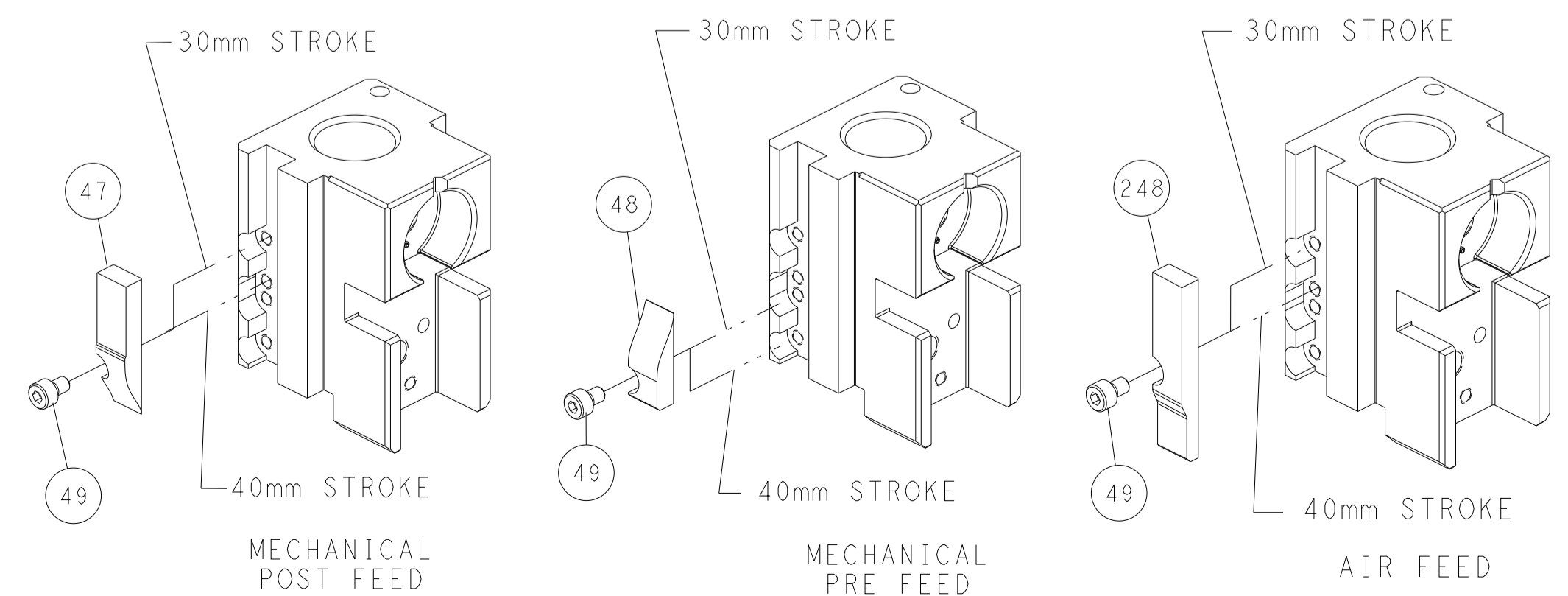

SHEAR DEPRESSOR DETAIL

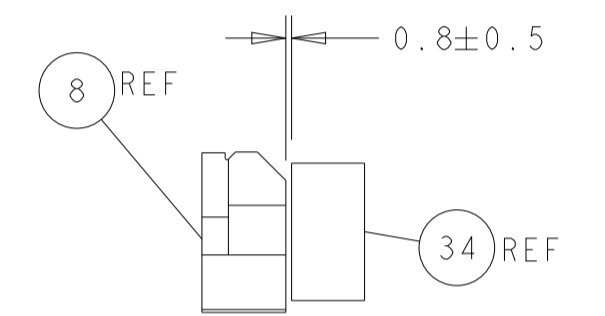

TERMINAL SUPPORT LOCATION

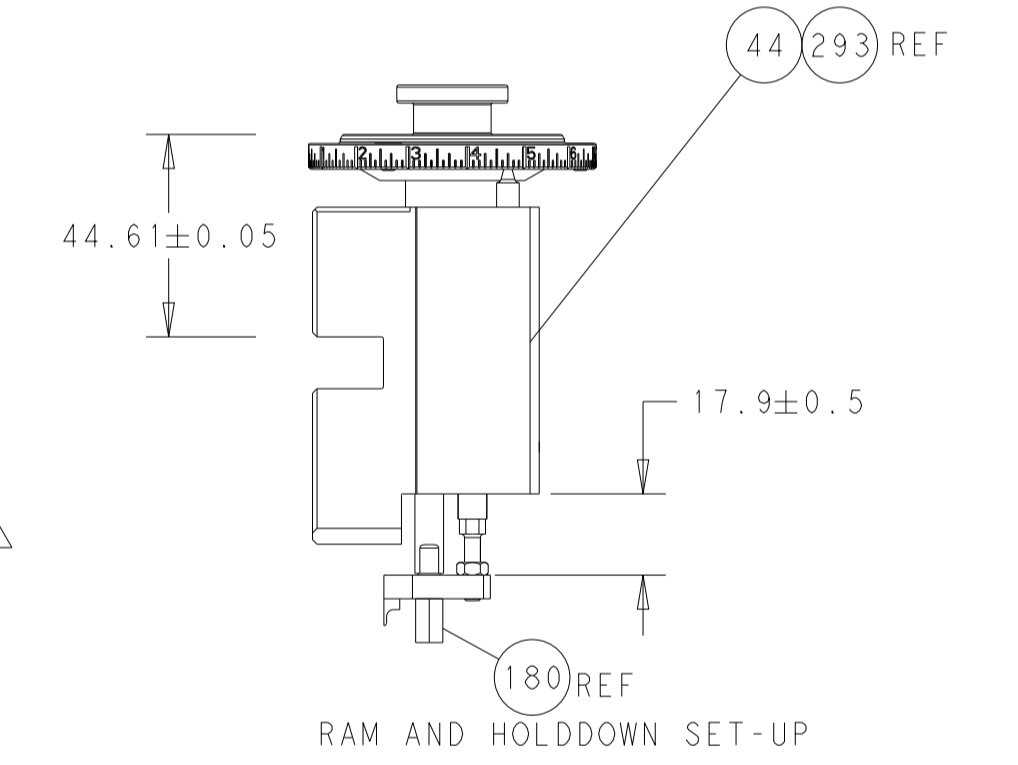

RAM AND HOLDDOWN SET-UP

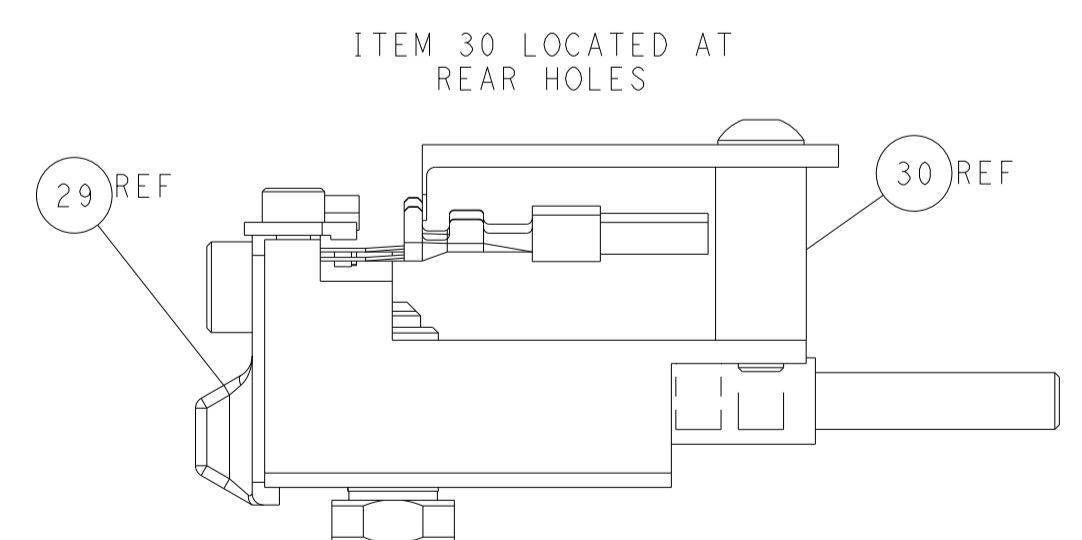

ITEM 30 LOCATED AT REAR HOLES

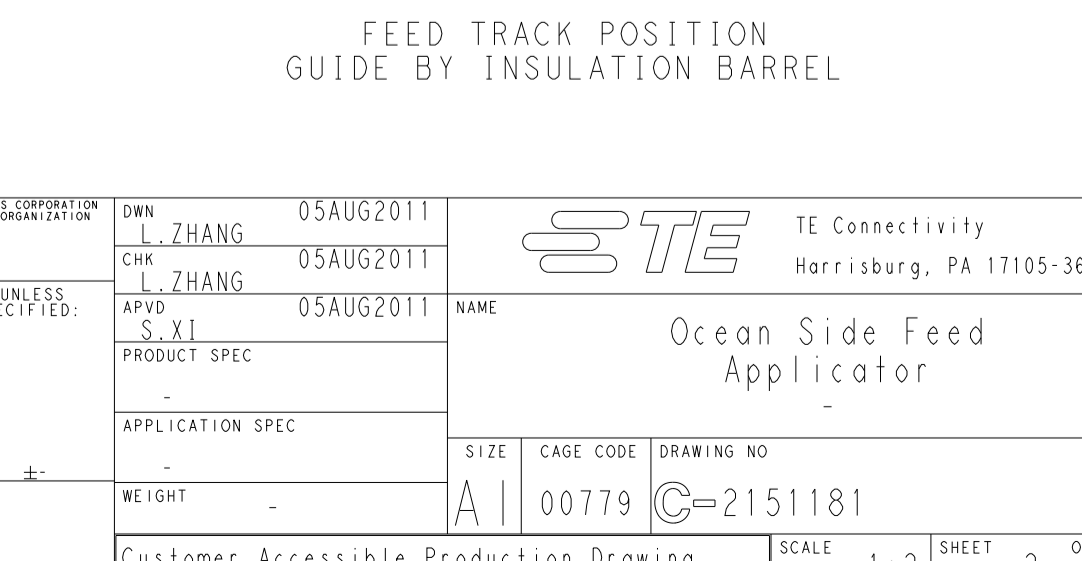

FEED TRACK POSITION GUIDE BY INSULATION BARREL

ATLANTIC VERSION
 Shown on sheets 1 of 4 & 2 of 4
 (Pacific version shown on sheets 3 of 4 & 4 of 4)

DIMENSIONS:		TOLERANCES UNLESS OTHERWISE SPECIFIED:		DWG		REV	
mm	0 PLC	±		L. ZHANG	05AUG2011	NAME	Ocean Side Feed Applicator
	1 PLC	±		L. ZHANG	05AUG2011	SIZE	A1
	2 PLC	±		S. XI	05AUG2011	CAGE CODE	00779
	3 PLC	±				DRAWING NO	2151181
	4 PLC	±				RESTRICTED TO	
	ANGLES	±				SCALE	1:2
	FINISH	±				SHEET	2 of 4
MATERIAL						REV	D1

PART NUMBER	REVISION	DESCRIPTION	FEED TYPE
2-2151181-1	C	FINE CRIMP HEIGHT ADJUST	MECHANICAL
2-2151181-2	D	FINE CRIMP HEIGHT ADJUST	PNEUMATIC
7-2151181-7	B	CRIMP TOOLING KIT	-

PACIFIC VERSION TERMINATOR
INTERFACE ADAPTER

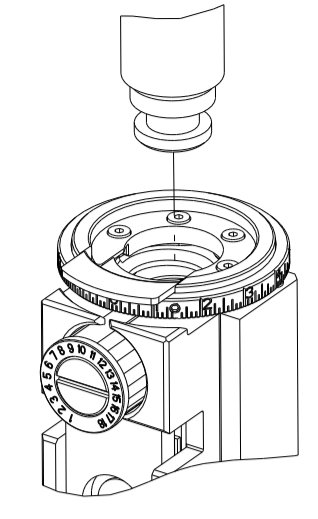

APPLICATOR DATA		
CRIMP	SIZE	TYPE
WIRE	2.03 mm [.080]	F
INSUL	4.06 mm [.160]	O
APPLICATOR INSTRUCTIONS 408-35042		

TERMINAL DATA: TE TERMINAL		TE CRIMP SPECIFICATION	
TERMINAL NAME: TAB 2.8 x 0.8			
WIRE STRIP LENGTH		INSULATION DIAMETER RANGE	
4.20-4.80 mm [1.65-.189 IN]		Ø 0.00-3.40 mm [0.000-.134 IN]	
TERMINAL APPLICATION SPECIFICATION	114-18051		

TERMINALS APPLIED				
TE TERMINAL	TE TERMINAL	TE SEAL	TE SEAL	CABLE DIAMETER
1-962915-1	2-962915-1		828904-1	Ø 1.2-2.1mm
1-962915-2	2-962915-2		828904-2	
1-962915-3	2-962915-3		828904-3	
	6-962915-6			

WIRE SIZE	CRIMP HEIGHT mm [INCH]	CRIMP HEIGHT REFERENCE SETTING
1.00mm ²	1.20 +/- 0.05 [0.047 +/- .002]	5.4
0.75mm ²	1.18 +/- 0.05 [0.046 +/- .002]	5.6
0.50mm ²	1.15 +/- 0.05 [0.045 +/- .002]	5.9

TERMINAL DATA: TE TERMINAL		TE CRIMP SPECIFICATION	
TERMINAL NAME: TAB 2.8 x 0.8			
WIRE STRIP LENGTH		INSULATION DIAMETER RANGE	
4.20-4.80 mm [1.65-.189 IN]		Ø 3.40 mm [.134 IN] MAX	
TERMINAL APPLICATION SPECIFICATION			

TERMINALS APPLIED				
TE TERMINAL	TE TERMINAL	TE SEAL	TE SEAL	CABLE DIAMETER
1-962915-3			828904-1	Ø 1.2-2.1mm
			828904-2	
			828904-3	

WIRE SIZE	CRIMP HEIGHT mm [INCH]	CRIMP HEIGHT REFERENCE SETTING
0.61mm ²	1.18 +/- 0.03 [0.046 +/- .001]	6.2

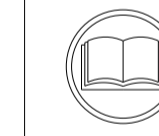

1. RECOMMENDED SPARE PARTS
2. REFER TO SUPPLIED INSTRUCTION SHEET FOR CLEANING, LUBRICATION AND STORAGE OF APPLICATOR.
3. APPLY PART NUMBER 2-23419-6 LOCTITE TO THREADS OF ITEM 242.
4. CRIMP HEIGHT REFERENCE SETTING WAS THE SETTING USED WHEN THE APPLICATOR WAS QUALIFIED AT THE FACTORY. ADJUSTMENT MAY BE NECESSARY WHEN RUNNING APPLICATOR IN THE FIELD.
5. APPLY TORQ-SEAL IN ALLEN SOCKET TO FILL HOLE AFTER FLAT HD HAS BEEN ADJUSTED TO CORRECT HEIGHT AT QUALIFICATION. APPLY #1-23419-5 LOC-TITE TO THREADS.
6. THIS CRIMP PARAMETER IS PROVIDED TO MEET A CUSTOM AND UNIQUE CUSTOMER REQUIREMENT. IT HAS BEEN EVALUATED AND IS CONDITIONALLY SPECIFIED BY TE CONNECTIVITY. THIS CUSTOMIZED CRIMP PARAMETER IS NOT LISTED AS AN APPROVED APPLICATION WITHIN A TE CONNECTIVITY APPLICATION SPECIFICATION; HOWEVER, IT HAS BEEN VALIDATED ACCORDING TO TE CONNECTIVITY SPECIFICATION 109-18079 (TEST GROUP 1) AND 114-18022. TE CONNECTIVITY EXPRESSLY DISCLAIMS ANY AND ALL WARRANTIES THAT THE PRODUCT WILL PERFORM SIMILARLY TO VALIDATED AND APPROVED APPLICATIONS, AS STATED WITHIN TE CONNECTIVITY APPLICATION SPECIFICATIONS, INCLUDING BUT NOT LIMITED TO IMPLIED WARRANTIES OF MERCHANTABILITY OR FITNESS FOR PARTICULAR PURPOSE. AS SUCH, IT IS HIGHLY RECOMMENDED THAT THE CUSTOMER PERFORM FURTHER DETAILED EVALUATION TO ASSESS PRODUCT PERFORMANCE IN THE SPECIFIC APPLICATION.
7. UNLESS SPECIFIED OTHERWISE TORQUE VALUES SHALL BE USED PER DOCUMENT, 101-35000.

***WARNING**
ON INSTALLATION, SET WIRE DISC TO CRIMP HEIGHT REFERENCE SETTING FOR LARGEST WIRE SIZE. CRIMP HEIGHT REFERENCE SETTINGS GREATER THAN THE VALUE SHOWN MAY CAUSE DAMAGE TO THE CRIMP TOOLING, REFER TO THE INSTRUCTION SHEET FOR PROPER SETUP AND ADJUSTMENTS.

ENTRY LEVEL APPLICATOR		ITEM SUBSTITUTION LIST		
PART NUMBER	SAME AS	ITEM	ITEM DESCRIPTION	SUBSTITUTE PART NUMBER
8-2151181-1	2151181-1	1	WIRE CRIMPER	1-1803590-6
8-2151181-2	2151181-2	3	INSULATION CRIMPER	1-1803624-8
9-2151181-1	2-2151181-1	46	BASIC SUB -ASSEMBLY	1803940-9
9-2151181-2	2-2151181-2	141	BASIC SUB -ASSEMBLY	1-1803940-0
			LUBRICATOR	DELETE

PACIFIC VERSION
Shown on sheets 3 of 4 & 4 of 4
(Atlantic version shown on sheets 1 of 4 & 2 of 4)

LOC	DIST	REVISIONS				
A	66	P LTR	DESCRIPTION	DATE	OWN	APVD
		-	SEE SHEET 1	-	-	-

-	1	1	2119082-9	CAM, SNAIL, INSULATION ADJUSTMENT	244
-	1	1	2079764-1	WASHER, WAVE SPRING, CREST-TO-CREST	243
-	1	1	2119083-1	RETAINER, INSULATION DIAL	242
-	1	1	7-18023-7	SCR, SKT HD CAP M3 X 4.0	241
-	-	1	2119580-1	MECHANICAL FEED ASSEMBLY	239
-	1	-	2844940-1	AIR FEED MODULE	238
-	REF	REF	994970-2	COUNTER, MAGNETIC	164
-	1	-	2119641-2	FEED CAM, AIR FEED	151
-	1	1	2168083-8	SCR, SKT HD CAP, RoHS, M4 X 16	144
-	4	4	2168083-9	SCR, SKT HD CAP, RoHS, M4 X 20	143
-	-	1	2119653-2	FEED CAM, POST FEED	142
-	1	1	1-1803583-0	APPLICATOR BASIC ASSEMBLY, SF	141
-	1	1	1803516-1	RAM ASSEMBLY, SF PACIFIC	140
-	1	1	2844908-1	SCREW, LOCKING	99
-	1	1	2844907-1	POST, LOCKING	98
-	1	1	455888-4	SPACER, CRIMPER	82
-	1	1	1803607-3	DOCUMENTATION PACKAGE	71
-	1	1	2119791-9	DEPRESSOR, WIRE	70
-	1	1	2119943-1	WASHER, SPACER	69
-	1	1	2119740-1	TAG, IDENTIFICATION	67
-	2	2	2168078-1	SCREW, DRIVE, RH, RoHS, 2 x .188	66
-	1	1	5-18022-5	SCR, HEX HD CAP, M4 X 6.0	59
-	1	1	985575-3	SCR, FLT SKT HD CAP M3 X 10.0	57
-	1	1	1338685-1	PAWL, FEED	56
-	2	2	2-2168083-5	SCR, SKT HD CAP, RoHS, M4 X 14	53
-	1	1	1803382-6	HOLD DOWN, SPRING LOADED	50
-	1	2	18023-9	SCR, SKT HD CAP M4 X 6.0	49
-	-	1	2119652-1	FEED CAM, PRE FEED	48
-	1	1	1803602-1	SCR, BHSC, RoHS (M8 X 25)	41
-	1	1	1-1752356-6	SUPPORT, TERMINAL	34
-	2	2	2079383-5	SCR, BHSC, RoHS (M4 X 20)	33
-	2	2	3-2844962-0	SPACER, CYLINDRICAL, STRIP GUIDE	30
-	1	1	2844992-2	ASSEMBLY, STRIP GUIDE	29
-	1	1	455888-3	SPACER, CRIMPER	28
-	1	1	1320928-6	STRIP GUIDE	24
-	1	1	2168083-2	SCR, SKT HD CAP, RoHS, M4 X 8.0	21
-	2	2	1-18028-2	WASHER, FLAT, REG M4	20
-	1	1	2119533-1	STRIPPER, SIDE FEED	19
-	1	1	2119806-1	INSERT, SHEAR	13
-	1	1	3-22280-3	SPRING, COMPRESSION	12
-	1	1	1-356885-4	STOP, SHEAR	11
-	1	1	2119805-1	SHEAR HOLDER, FRONT	10
-	1	1	318707-1	FLOATING SHEAR, FRONT	9
-	1	1	1-1803554-4	ANVIL, COMBINATION	8
-	-	1	240641-5	SPACER	7
-	1	1	2119781-1	DEPRESSOR, SHEAR	5
-	1	1	238011-7	BLOCK, CRIMPER SPACER	4
-	1	1	1-1633965-8	CRIMPER, INSULATION O PREMIUM	3
-	1	1	1-455888-1	SPACER, CRIMPER	2
-	1	1	1-456405-6	CRIMPER, WIRE PREMIUM	1

DIMENSIONS:		TOLERANCES UNLESS OTHERWISE SPECIFIED:		MATERIAL:		FINISH:		WEIGHT:		SCALE:	
mm	0 PLC ±	1 PLC ±	2 PLC ±	3 PLC ±	4 PLC ±	ANGLES	FINISH				

LOC	DIST	REVISIONS					
A	66	P	LTN	DESCRIPTION	DATE	DWN	APVD
		-		SEE SHEET 1			

FEED TYPE MECHANICAL

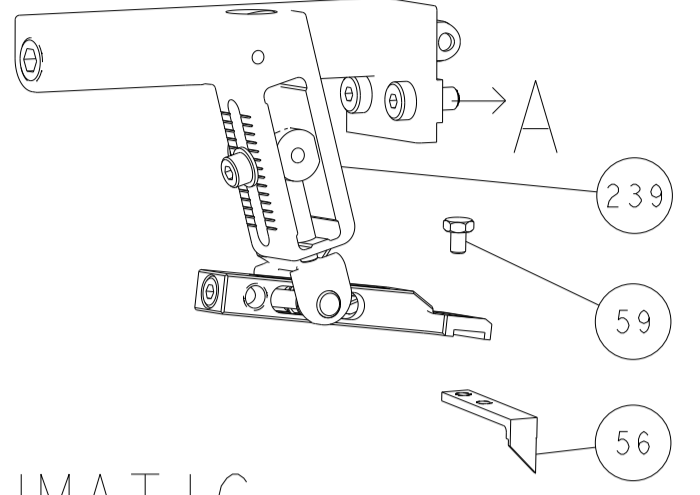

PNEUMATIC

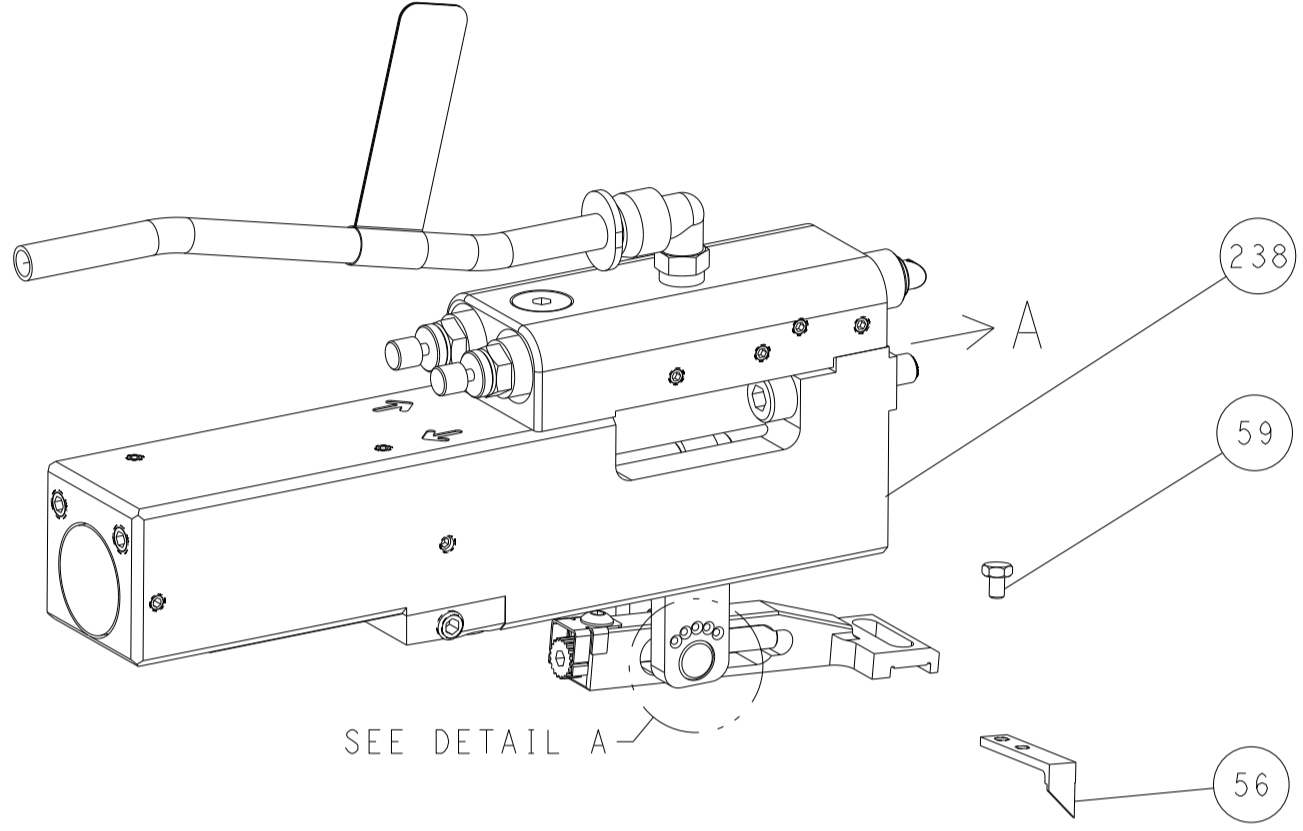

FEED SPRING SETTING POSITION (SHOWN FROM REAR SIDE)

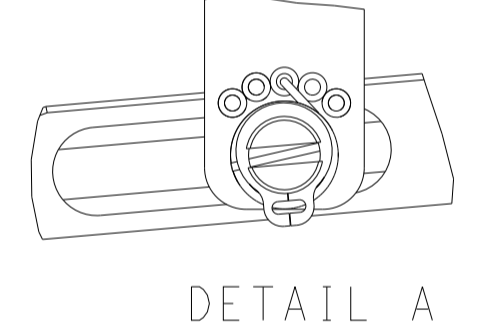

CAM POSITIONS

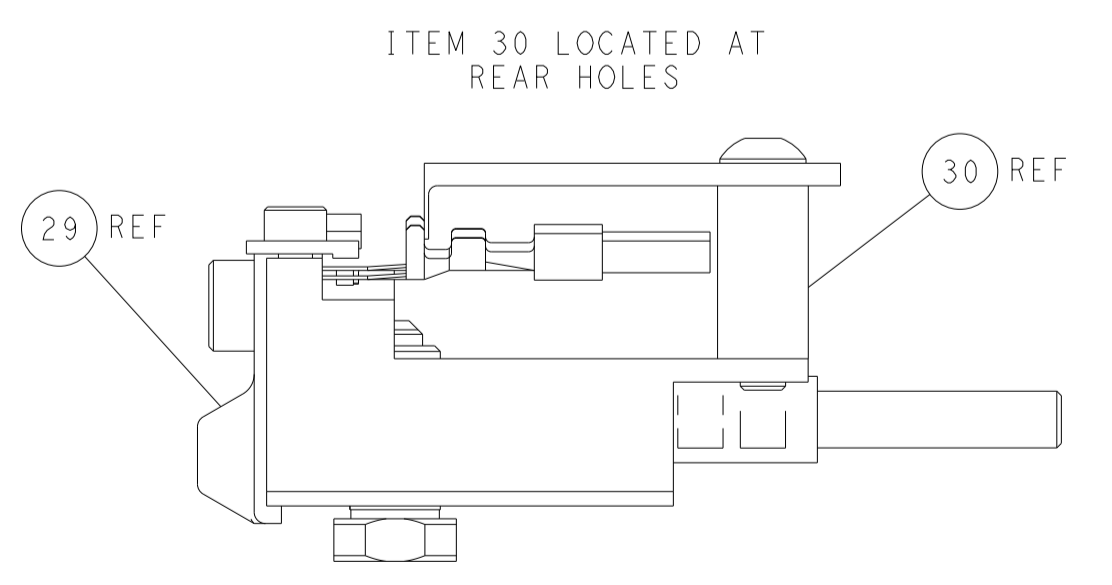
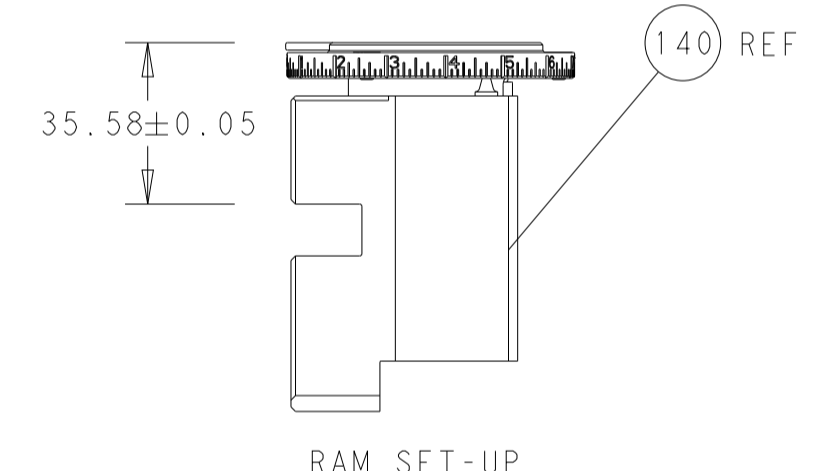
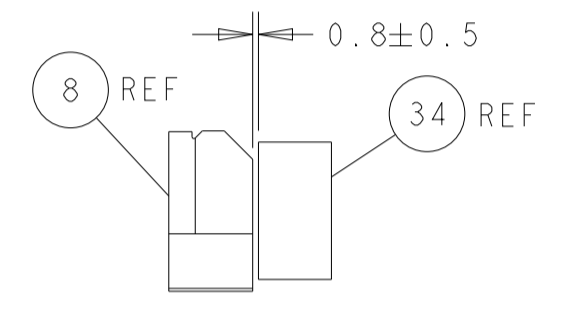
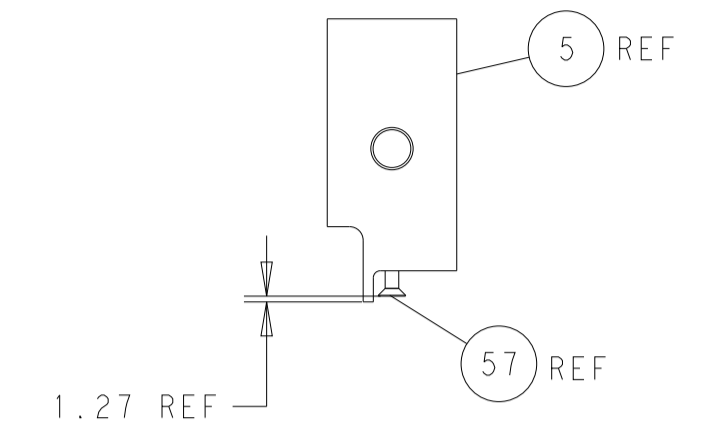
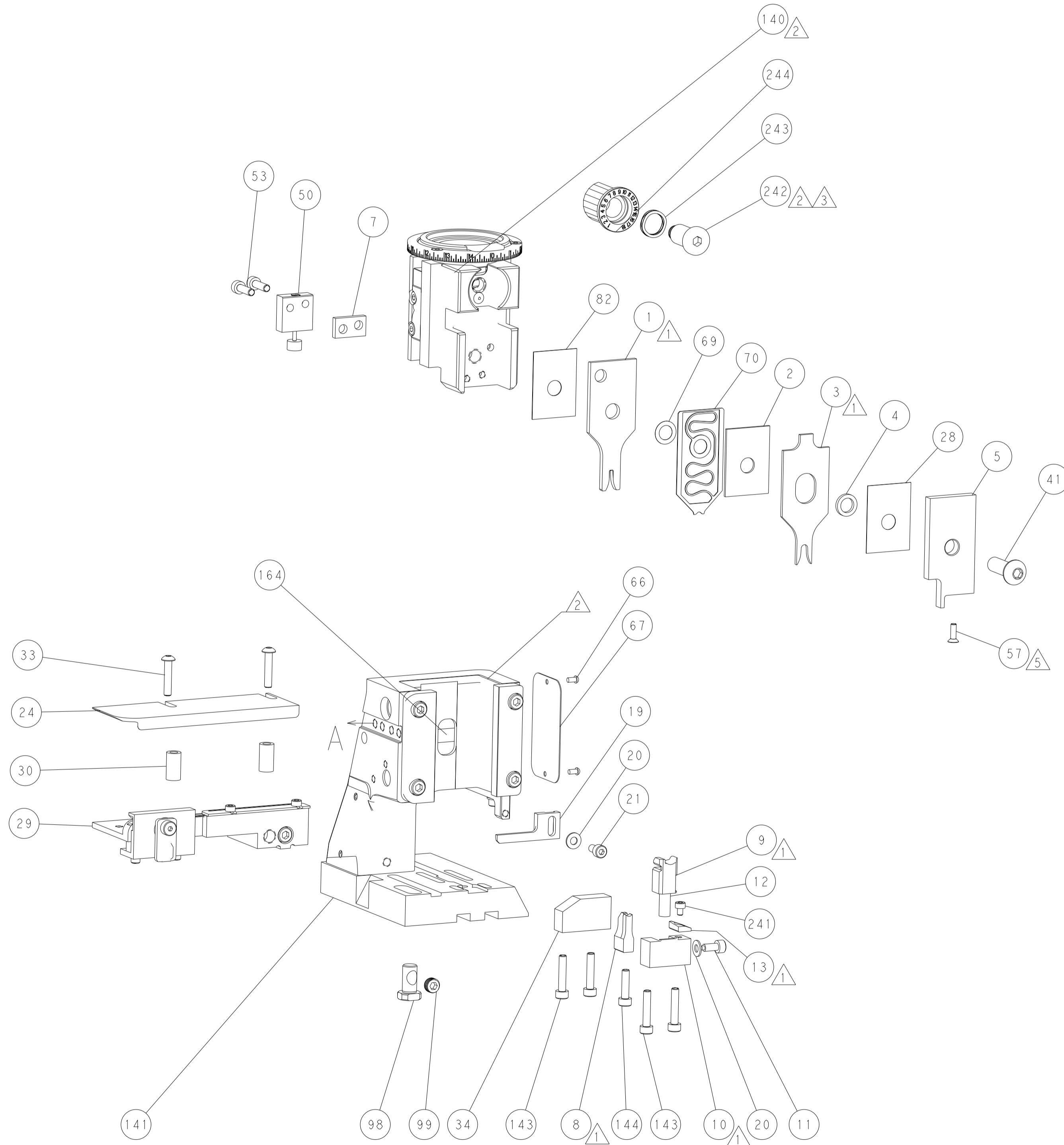
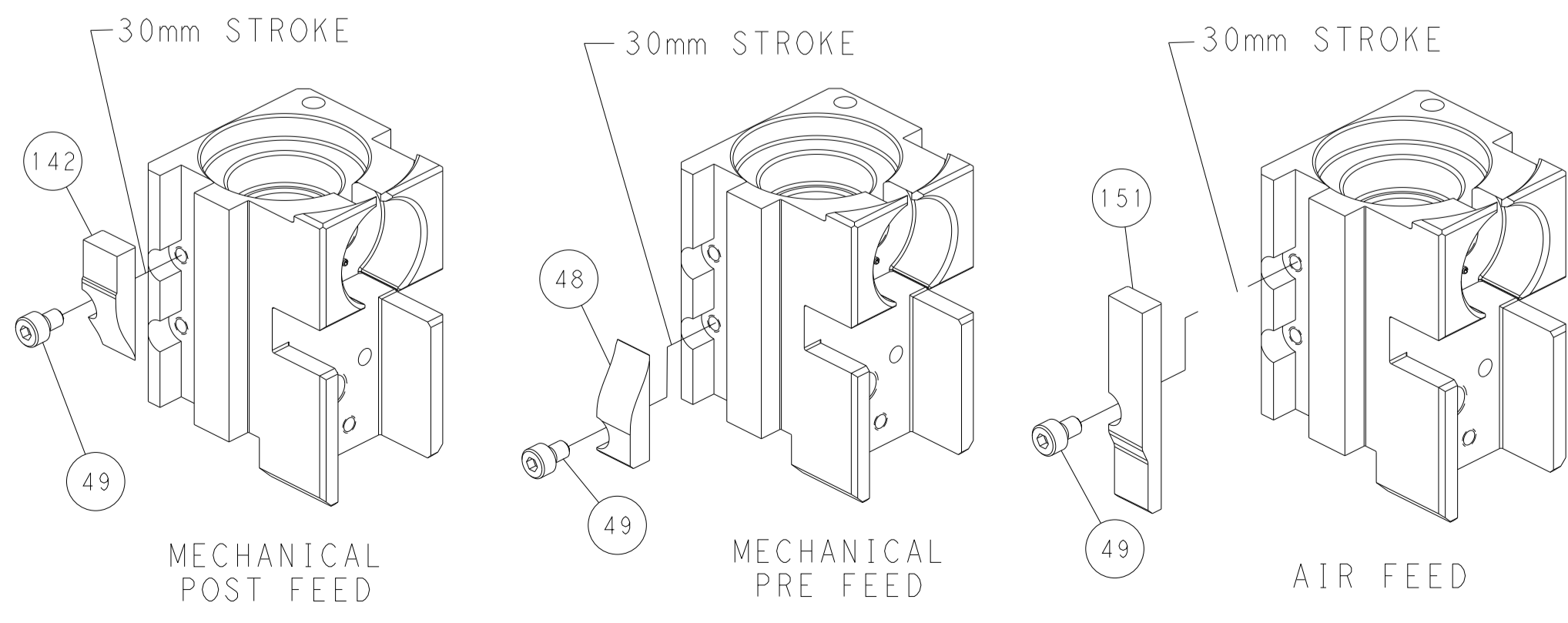

PACIFIC VERSION
 Shown on sheets 3 of 4 & 4 of 4
 (Atlantic version shown on sheets 1 of 4 & 2 of 4)

<small>THIS DRAWING IS A CONTROLLED DOCUMENT FOR TYCO ELECTRONICS CORPORATION. IT IS THE PROPERTY OF COMPANY AND IS NOT TO BE REPRODUCED OR TRANSMITTED IN ANY FORM OR BY ANY MEANS, ELECTRONIC OR MECHANICAL, INCLUDING PHOTOCOPYING, RECORDING, OR BY ANY INFORMATION STORAGE AND RETRIEVAL SYSTEM, WITHOUT THE WRITTEN PERMISSION OF TYCO ELECTRONICS CORPORATION.</small>		DWN L. ZHANG 05AUG2011 CHK L. ZHANG 05AUG2011 S. XI 05AUG2011 APVD S. XI 05AUG2011	NAME Ocean Side Feed Applicator
DIMENSIONS: mm 	TOLERANCES UNLESS OTHERWISE SPECIFIED: 0 PLC ± 1 PLC ± 2 PLC ± 3 PLC ± 4 PLC ± ANGLES ± FINISH	PRODUCT SPEC APPLICATION SPEC WEIGHT SCALE 1:2	SIZE CAGE CODE DRAWING NO A1 00779 C-2151181 SHEET 4 OF 4 REV D1