

UNIT:MM

REVISION INFORMATION

Rev.	Rev. Date	Modified By	Brief Description
A/0	18-07-02	T0702A	NEW DRAWING
A/1	18-08-30	B0829A	修改成型胶粒硬度

PIN ASSIGNMENT:

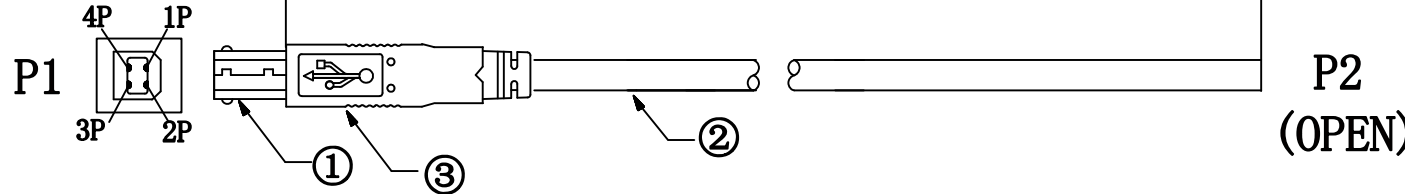
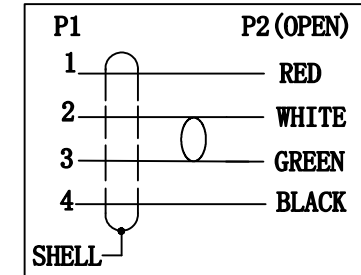

Electrical test:

- 100% short, open, miswire test
- Conduct resistance: 2 Ohm (max)
- Insulation resistance: 5Mohm (min)
- dielectric test: DC 300V

CABLE WHITE PRINT

E166160 AWM 2725 80°C 30V
28AWGX1P+24AWGX2C USB2.0

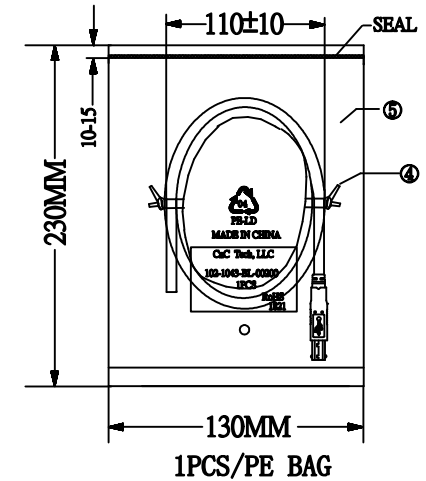

PART NO	WIRE LENGTH "L"	BUYER COLOR	VENDOR COLOR	CUT LENGTH
102-1043-BL-00200	2000±40		BLACK	2000-2010MM

NO.	NAME	QTY	SPECIFICATION
⑥	PE BAG	1/10	CLEAR SIZE:280X330X0.05mm PRINT BLACK "MADE IN CHINA" + "10PCS"
⑤	PE BAG	1	CLEAR SIZE:130X230X0.05mm PRINT BLACK "MADE IN CHINA" + "1PC"
④	TIE	2	BLACK L=100mm
③	MOLDED	12g	BLACK PVC-55P (MOULD NO:BM-2-X)
②	CABLE	1	BLACK USB2.0 UL2725 28#/1P+24#2C+AEB OD:4.7mm
①	CONN	1set	USB2.0 B MALE SHELL:NICKEL PIN G/F 3PCS TYPE INSULATOR COLOR:WHITE

CnC Tech, LLC
Industrial Cable and Connector Technology

DRAWN BY:	DATE: 2018/08/30	DESCRIPTION: 4C CABLE USB B/M+OPEN
CHECKED BY:	SHEET 1 of 1	ITEM NO. As above
APPROVED BY:	SCALE 1:1	REV. A/1 UNIT: mm