

REVISIONS					
P	LTR	DESCRIPTION	DATE	DMN	APVD
D1		REVISED PER ECO-16-004000	28SEP2016	NK	MZ
E		REVISED PER ECR-17-002063	07MAR2017	RS	MZ

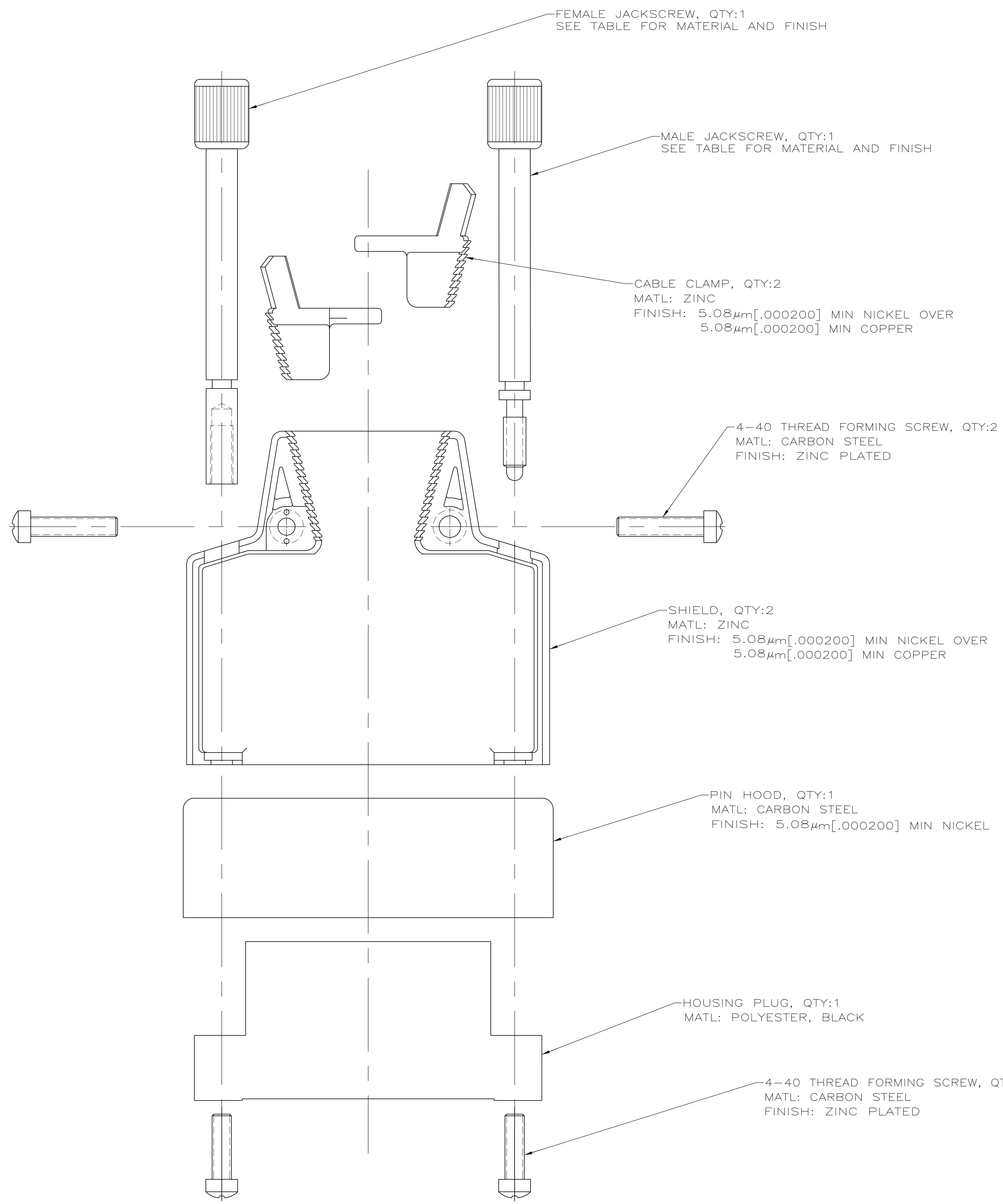

- 1 OBSOLETE PARTS: OBSOLETE CIS STREAMLINING PER D.RENAUD/D.SINISI.
- 2 MATERIAL: ZINC  
FINISH: 2.54µm[.000100] MIN NICKEL OVER 2.54µm[.000100] MIN COPPER.
- 3 MATERIAL: STAINLESS STEEL.

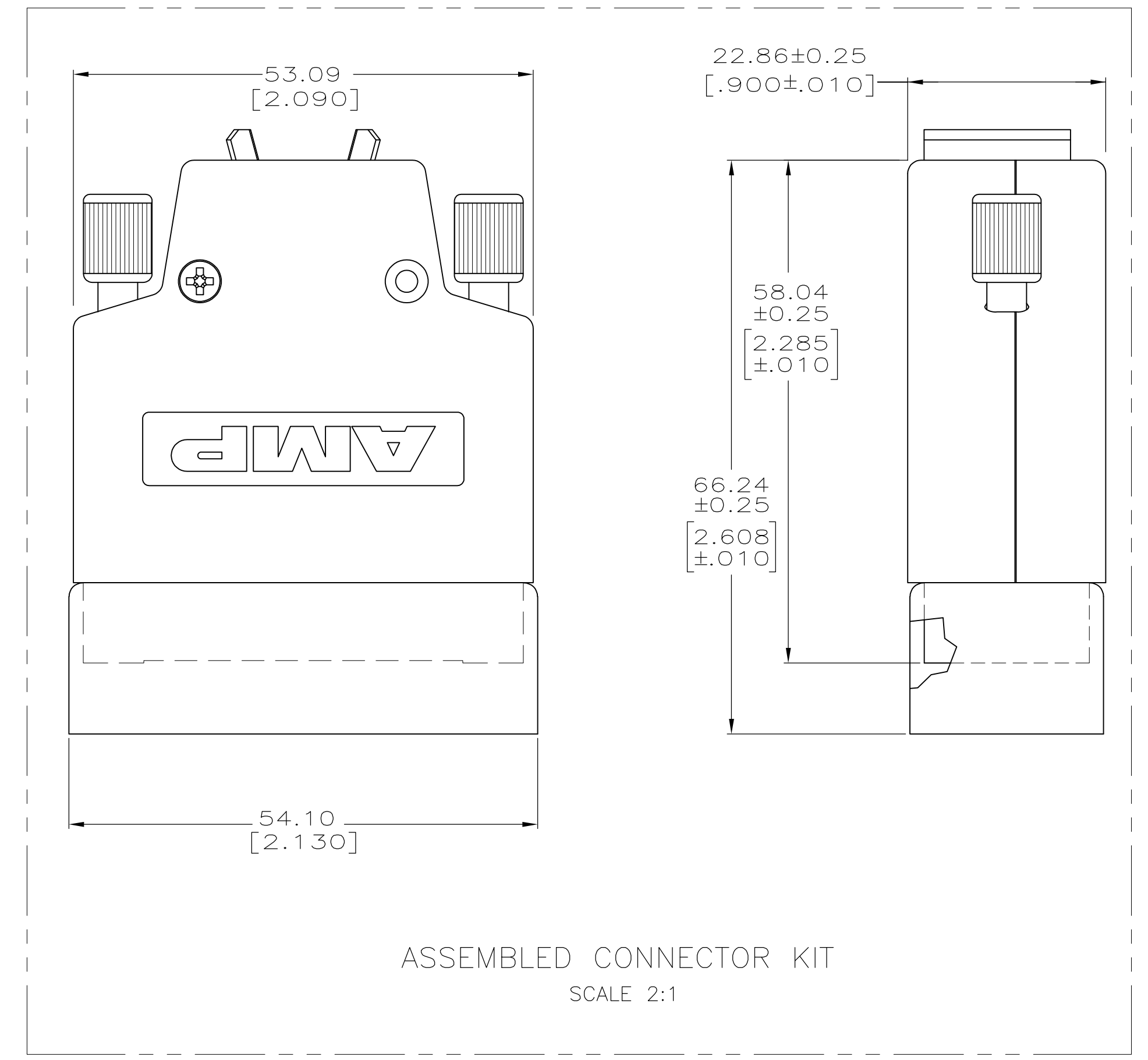

OBSOLETE	3	6.35-10.16[.250-.400]	2+3804-4
	2	10.16-15.24[.400-.600]	213804-3
1 OBSOLETE	2	6.35-10.16[.250-.400]	2+3804-2
OBSOLETE	2	3.81-7.62[.150-.300]	2+3804-1
		JACKSCREW	CABLE DIAMETER
			PART NO

THIS DRAWING IS A CONTROLLED DOCUMENT.

DIMENSIONS: mm [INCHES]	TOLERANCES UNLESS OTHERWISE SPECIFIED: 0. PLC ± - 1. PLC ± - 2. PLC ± 0.13[.005] 3. PLC ± - 4. PLC ± - ANGLES ± -	DIN D. BROCKWAY 08-16-94 CIRK R. STONE 10-05-94 APVD T. COULSON 10-05-94 PRODUCT SPEC APPLICATION SPEC	STE TE Connectivity CONNECTOR KIT, UNASSEMBLED, 34 POSITION, V.35, M SERIES
MATERIAL SEE CALLOUTS	FINISH SEE CALLOUTS	SIZE A1 CAGE CODE 00779 DRAWING NO. 213804	RESTRICTED TO CUSTOMER DRAWING

SCALE 3:1 SHEET 1 OF 1 REV E