

0.3mm Pitch, Vertical mating, Board-to-Micro Coaxial Cable Connectors

DF56 Series

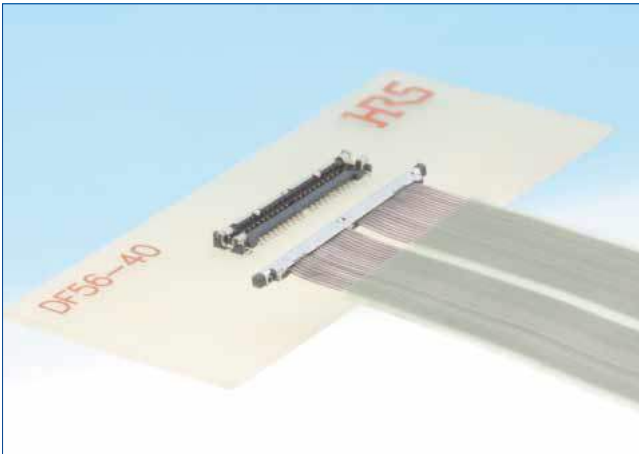

High contact reliability

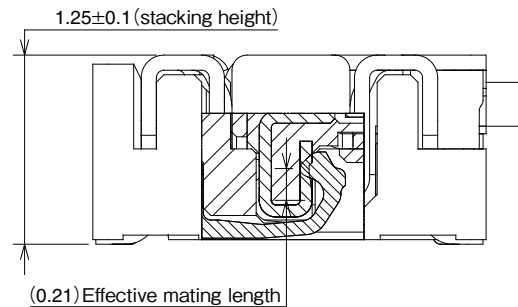

Fig.1

■ Features

1.Small mated height and board occupied space

Small pitch (0.3mm) and mated height (1.25mm) allows use in space-restricted areas. It's a small connector with mated height of 1.25mm (1.35mm MAX) and depth of 2.6mm.

2.Compatibility with small diameter hinges

AWG44 x 40 are compatible with hinge diameters of $\phi 2.8$ mm, which allows wiring in small hinge in side devices.

3.Reliable electrical and mechanical connection

Despite its small mated height, unique contact configuration assures highly reliable connection, with effective mating length of 0.21mm.(Fig.1)

4.Durable plug construction

Formed metal shells on the top and side surfaces form a strong and rigid assembly.

5.Enhanced shielding and ground connections

Metal shells on the plug and receptacle connect to each other with a reliable multi-point ground contacts, assuring reliable ground connection and EMC protection. (Fig.2)

6.Reliable lock

Fully mated condition is assured with reliable locks at 4 locations, confirming it with a distinct tactile click. (Fig.3)

7.Solder wicking prevention

Nickel barriers prevent solder wicking in the critical contact areas.

8.RoHS, Halogen-free*

*As defined by IEC61249-2-21

Br-900 ppm maximum, Cl-900 ppm maximum,
Cl + Br combined-1,500 ppm maximum.

Enhanced shielding

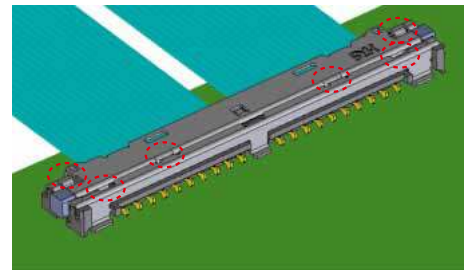

Multi-point ground contacts

Fig.2

Distinct tactile click

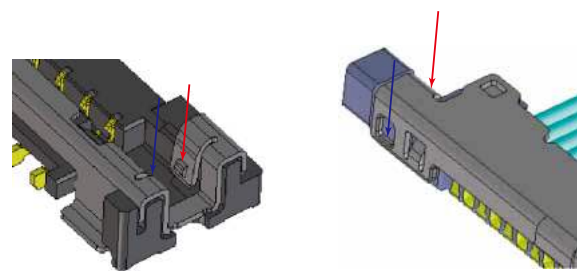

4-point lock : 2 points at each end

Fig.3

■ Connectors for conductivity tests

We have a line-up of plug and receptacle connectors for inspection, usable for electrical testing.

Specifications

Ratings	Current rating	0.2A (42 AWG) 0.15A (44 AWG) 0.1A (46 AWG)	Operating temperature range : Operating humidity range:	-35 to +85°C (Note 1) 20% to 80% RH
	Voltage rating 30Vrms AC	30V AC	Storage temperature range : Storage humidity range :	-10 to +60°C (Note 2) 40% to 70% RH

Item	Specification	Conditions
1. Insulation resistance	50MΩ min.	100V DC
2. Withstanding voltage	No flashover or insulation breakdown	100Vrms AC / 1 minute
3. Contact resistance	Signal : 80mΩ max, Ground 80mΩ max	100mA (DC or 1,000Hz)
4. Vibration	No electrical discontinuity of 1μs or longer	Frequency : 10 to 55Hz, single amplitude of 0.75mm, 10 cycles in each of the 3 axis
5. Humidity	Contact resistance (change from initial value) 50mΩ max. Insulation resistance : 25MΩ min.	96 hours at of 40 ±2°C, and humidity of 90 to 95%
6. Temperature cycle	Contact resistance (change from initial value) 50mΩ max. Insulation resistance : 25MΩ min.	-55°C → 5 to 35°C → 85°C → 5 to 35°C Time : 30 min. → 2 to 3 min. → 30 min. → 2 to 3 min. 5 cycles
7. Durability	Contact resistance (change from initial value) 50mΩ max.	20 cycles
8. Resistance to soldering heat	No deformation of affecting performance	Reflow : At the recommended temperature profile Manual soldering : 350°C for 3 seconds

Note1 : Includes temperature rise caused by current flow.

Note2 : The term "storage" refers to products stored for a long period prior to mounting and use. The operating temperature and humidity range covers the non-conducting condition of installed connectors in storage, shipment or during transportation after board mounting.

Note3 : Temperature rise of connector body only, and that of case is not included.

Materials / Finish

Product	Part	Material	Finish	Remarks
Receptacle	Insulator	LCP	Color:Black	UL94V-0
	Contacts	Phosphor bronze	Gold plated	—
	Metal fittings	Phosphor bronze	Tin plated	—
Plug	Insulator	LCP	Color:Black	UL94V-0
	Contacts	Phosphor bronze	Gold plated	—
	Metal cover	Stainless	Tin plated	—
Shell	Metal cover	Stainless	Tin plated	—

Product Number Structure

Refer to the chart below when determining the product specifications from the product number.
Please select from the product numbers listed in this catalog when placing orders.

Connector

DF **56** **J** - ***** **S** - **0.3** **V** **(**)**

① ② ③ ④ ⑤ ⑥ ⑦ ⑧

DF **56** **J** - ***** **P** - **SHL**

① ② ③ ④ ⑤ ⑨

① Series name : DF	⑥ Contact pitch : 0.3mm
② Series No. : 56	
③ Connector style C : Stand-off type (No pattern prohibited area under connector) J : Connector for conductivity tests Blank : Standard (With pattern prohibited area under connector)	⑦ Termination type V : Straight SMT SD : Fine coaxial cable plug
④ Number of contacts C : Stand-off type 26, 30, 40 Standard : 40, 50	⑧ Packaging (51) : Embossed tape packaging
⑤ Connector type S : Receptacle P : Plug	⑨ Installation item (separate) SHL : Metal cover

Combinations

[Standard use]

DF56-*S-0.3V(**) + DF56-*P-ASSY
 [DF56-*P-0.3SD(**)]
 [DF56-*P-SHL]

Note : The product specification of the above combination is shown on page 2.

[Receptacle conductivity test]

DF56-*S-0.3V(**) + DF56J-*P-ASSY(Note)
 [DF56-*P-0.3SD(**)]
 [DF56J-*P-SHL]

Note : This harness item is only usable for the receptacle test.

For the product specification of the above combination, please contact our sales department.

[Plug for conductivity test]

DF56J-*S-0.3V(**)(Note) + DF56-*P-ASSY
 [DF56-*P-0.3SD(**)]
 [DF56-*P-SHL]

DF56CJ-*S-0.3V(**) + DF56-*P-ASSY
 [DF56-*P-0.3SD(**)]
 [DF56-*P-SHL]

Note : This harness item is only usable for the plugs and receptacles test.

For the product specification of the above combination, please contact our sales department.

* : ASSY means a harness item.

■ Receptacle (SMT)



●40 pos

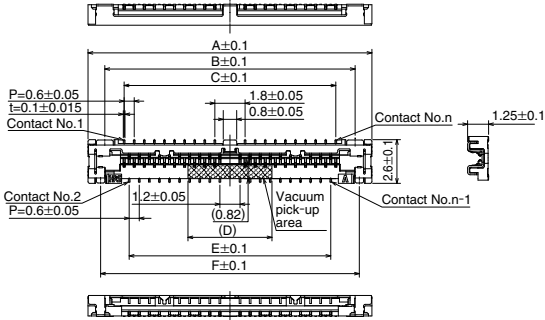

●50 pos

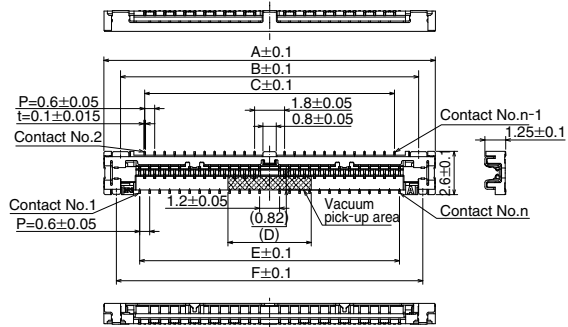

Note : The position of contact No.1 is different depending on No. of positions.

[Specifications number] - **, (**)
(51) : Embossed tape packaging

Unit : mm

Part No.	HRS No.	No. of contacts	A	B	C	D	E	F
DF56-40S-0.3V(**)	662-5600-0 **	40	16.90	14.90	12.60	(5.00)	12.00	15.40
DF56-50S-0.3V(**)	662-5606-7 **	50	19.90	17.90	15.00		15.60	18.40

◆ Recommended PCB mounting pattern

●40 pos

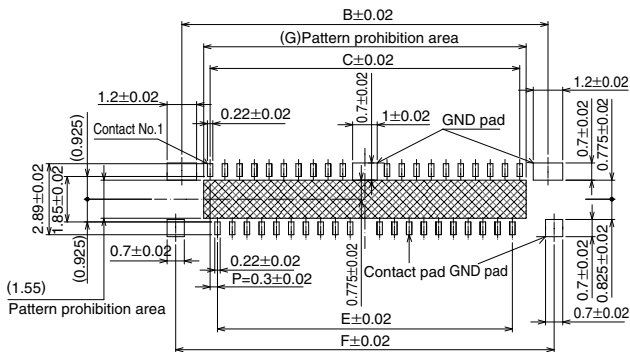

●50 pos

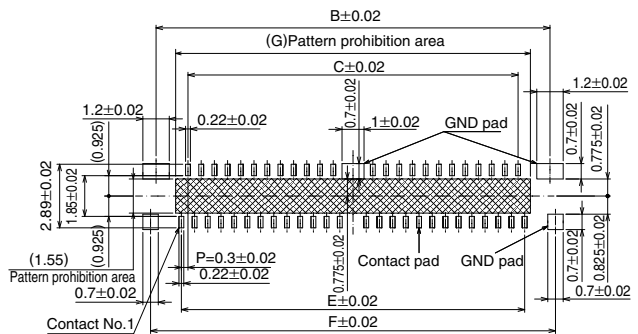

Note : The position of contact No.1 is different depending on No. of positions.

[Specifications number] - **, (**)
(51) : Embossed tape packaging

Unit : mm

Part No.	HRS No.	No. of contacts	B	C	D	E	F	G
DF56-40S-0.3V(**)	662-5600-0 **	40	14.90	12.60	(5.00)	12.00	15.40	13.12
DF56-50S-0.3V(**)	662-5606-7 **	50	17.90	15.00		15.60	18.40	16.12

Note 1 : Tape and reel packaging (5,000 pcs/reel).
Order by number of reels.

■ Receptacle (SMT).....Stand-off type



●26 pos/30 pos

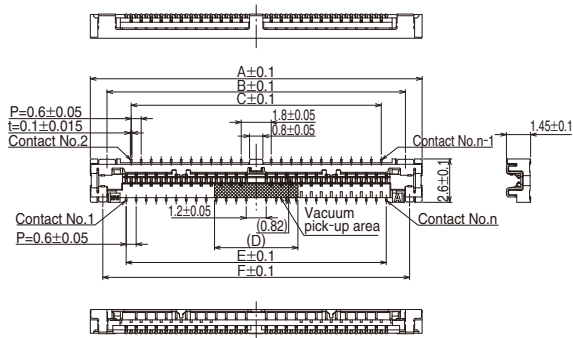

●40 pos

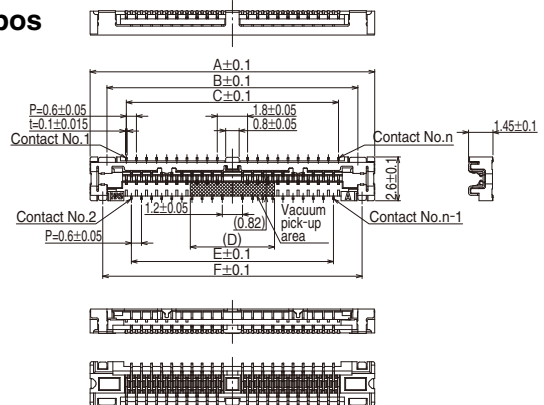

Note : The position of contact No.1 is different depending on No. of positions.

[Specifications number] - **, (**)
(51) : Embossed tape packaging

Unit : mm

Part No.	HRS No.	No. of contacts	A	B	C	D	E	F
DF56C-26S-0.3V(**)	662-5603-9 **	26	12.70	10.70	7.80	(5.00)	8.40	11.20
DF56C-30S-0.3V(**)	662-5616-0 **	30	13.90	11.90	9.00		9.60	12.40
DF56C-40S-0.3V(**)	662-5619-9 **	40	16.90	14.90	12.60		12.00	15.40

◆ Recommended PCB mounting pattern.....Stand-off type

●26 pos/30 pos

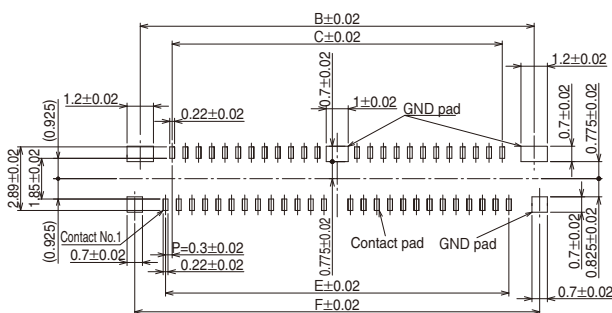

●40 pos

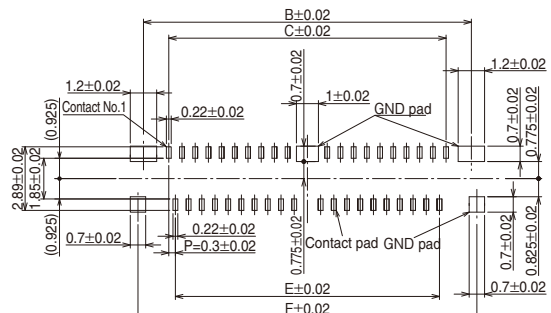

Note : The position of contact No.1 is different depending on No. of positions.

[Specifications number] - **, (**)
(51) : Embossed tape packaging

Unit : mm

Part No.	HRS No.	No. of contacts	B	C	E	F
DF56C-26S-0.3V(**)	662-5603-9 **	26	10.70	7.80	8.40	11.20
DF56C-30S-0.3V(**)	662-5616-0 **	30	11.90	9.00	9.60	12.40
DF56C-40S-0.3V(**)	662-5619-9 **	40	14.90	12.60	12.00	15.40

Note 1 : Tape and reel packaging (5,000 pcs/reel).
Order by number of reels.

■ Plug

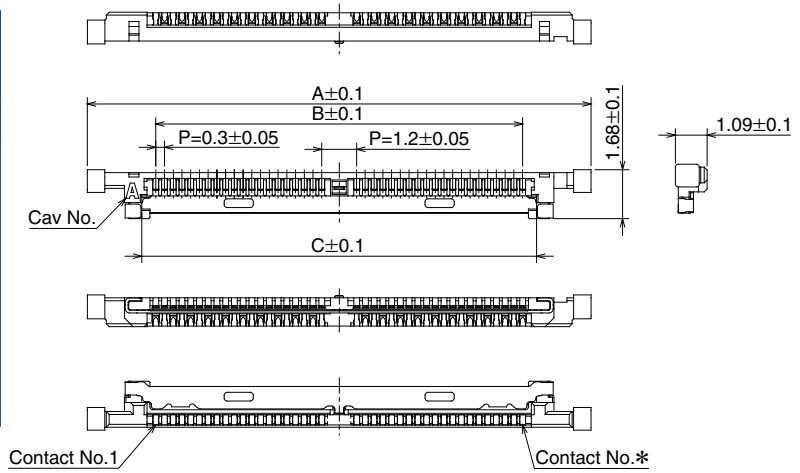

[Specifications number] - **, (**)
(51) : Embossed tape packaging

★ Standard type

Unit : mm

Part No.	HRS No.	No. of contacts	A	B	C	D
DF56-26P-0.3SD(**)	662-5604-1 **	26	13.10	8.40	9.36	9.20
DF56-30P-0.3SD(**)	662-5617-3 **	30	14.30	9.60	10.56	10.40
DF56-40P-0.3SD(**)	662-5601-3 **	40	17.30	12.60	13.56	13.40
DF56-50P-0.3SD(**)	662-5607-0 **	50	20.30	15.60	16.56	16.40

Note 1 : Tape and reel packaging (10,000 pcs/reel). Order by number of reels.

Note 2 : The metal cover (DF56-*P-SHL) is required for micro coaxial cable termination.

★ The type of emphasis for operation (A part in a different)

Unit : mm

Part No.	HRS No.	No. of contacts	A	B	C	D
DF56L-26P-0.3SD(**)	662-5623-6 **	26	13.50	8.40	9.36	9.20
DF56L-30P-0.3SD(**)	662-5625-1 **	30	14.70	9.60	10.56	10.40
DF56L-50P-0.3SD(**)	662-5626-4 **	50	20.70	15.60	16.56	16.40

◆ Recommended Micro Coaxial Cable Preparation

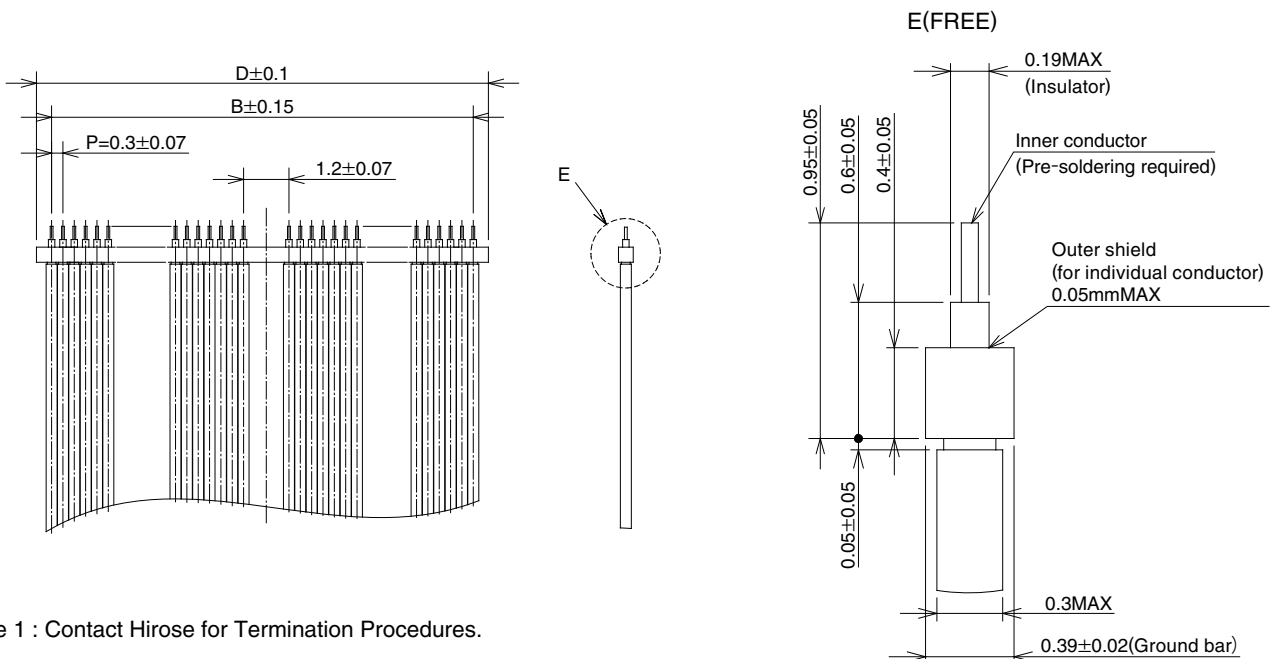

Note 1 : Contact Hirose for Termination Procedures.

■ Metal cover

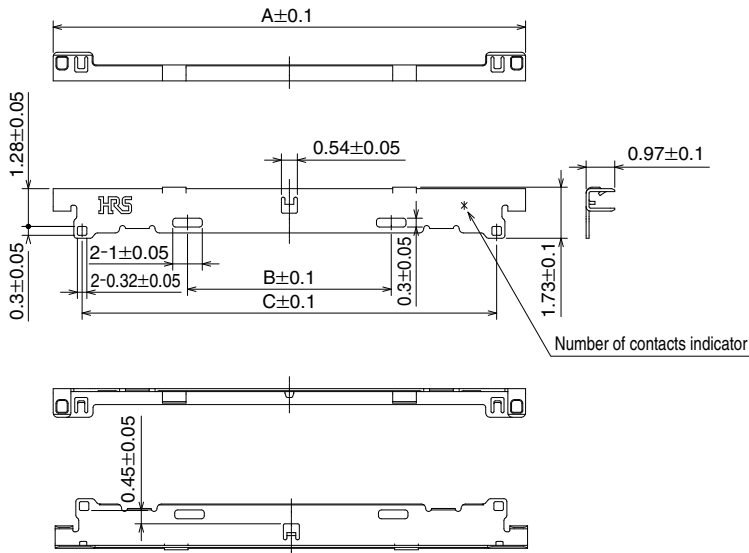

Unit : mm

Part No.	HRS No.	No. of contacts	A	B	C
DF56-26P-SHL	662-5605-4	26	11.80	3.90	9.84
DF56-30P-SHL	662-5618-6	30	13.00	3.90	11.04
DF56-40P-SHL	662-5602-6	40	16.00	6.90	14.04
DF56-50P-SHL	662-5608-2	50	19.00	7.50	17.04

Note 1 : Tape and reel packaging (10,000 pcs/reel). Order by number of reels.

◆ Packaging Specification

● Embossed Carrier Tape Dimensions—Receptacles

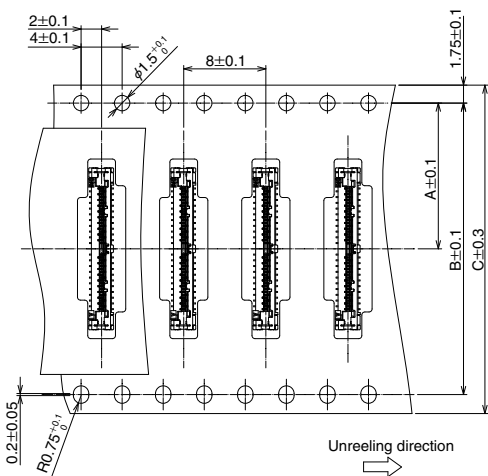

● Reel Dimensions

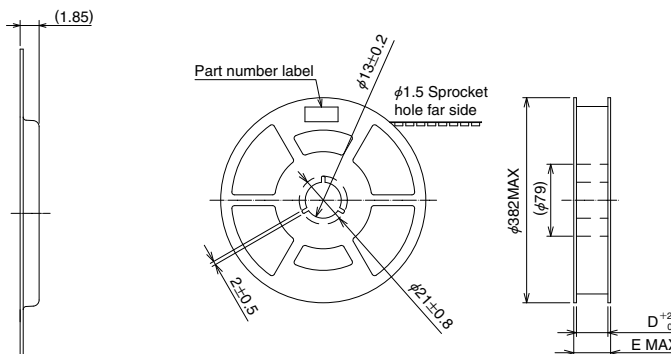

Unit : mm

Part No.	HRS No.	No. of contacts	A	B	C	D	E
DF56-40S-0.3V(**)	662-5600-0 **	40	14.2	28.4	32.0	32.4	38.4
DF56-50S-0.3V(**)	662-5606-7 **	50					

Note : When the number of contacts is 30 or less, the feed holes are only on one side of the tape. (Top of figure φ1.5 hole only)

◆ Embossed tape dimensions (JIS C 0806 compliant).....Stand-off type

● Receptacles

● Reel Dimensions

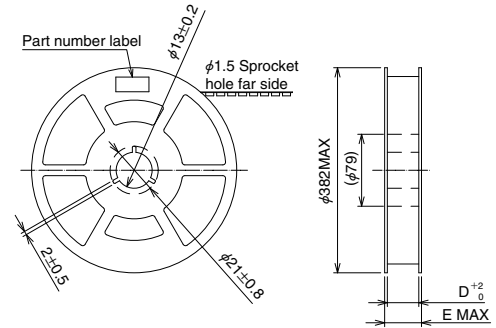
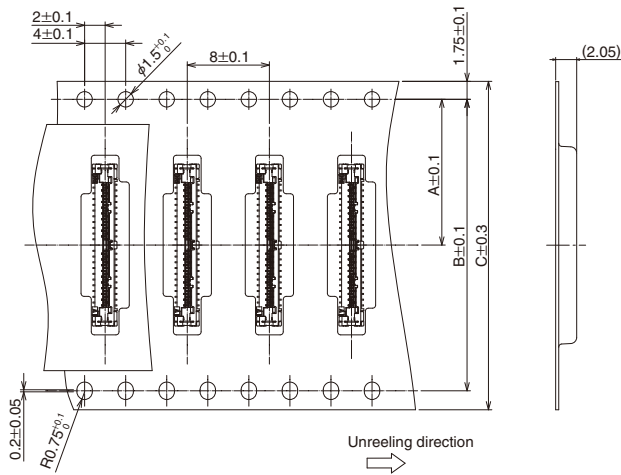

Unit : mm

Part No.	HRS No.	No. of contacts	A	B	C	D	E
DF56C-26S-0.3V(**)	662-5603-9 **	26	11.5	—	24.0	24.4	30.4
DF56C-30S-0.3V(**)	662-5616-0 **	30					
DF56C-40S-0.3V(**)	662-5619-9 **	40	14.2	28.4	32.0	32.4	38.4

Note : When the number of contacts is 30 or less, the feed holes are only on one side of the tape. (Top of figure φ1.5 hole only)

◆ Packaging Specification

● Embossed Carrier Tape Dimensions—Plugs

● Reel Dimensions

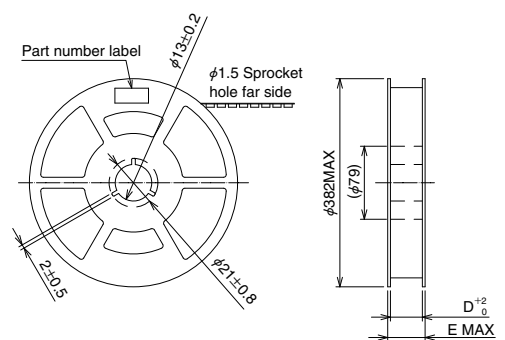
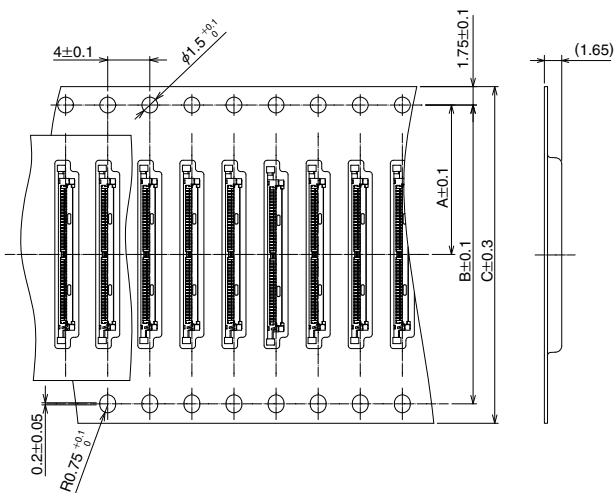

Unit : mm

Part No.	HRS No.	No. of contacts	A	B	C	D	E
DF56-26P-0.3SD(**)	662-5604-1 **	26	14.2	28.4	32.0	32.4	38.4
DF56-30P-0.3SD(**)	662-5617-3 **	30					
DF56-40P-0.3SD(**)	662-5601-3 **	40					
DF56-50P-0.3SD(**)	662-5607-0 **	50					

◆ Extraction tool

For details about the extraction tool, please contact your Hirose sales representative.

◆ Usage Recommendations

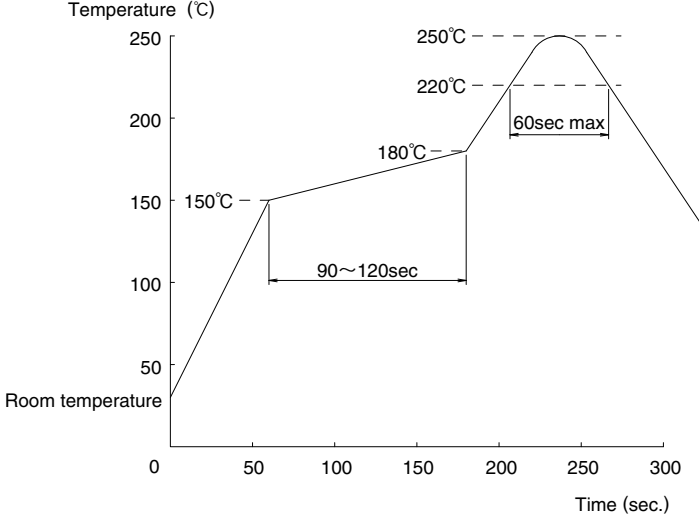
<p>1.Recommended temperature profile</p>	 <p>Applicable Conditions</p> <ol style="list-style-type: none"> 1. Peak Temperature : 250°C max. 2. Heating : 220°C min. for 60 seconds max. 3. Pre-heating : 150 to 180°C for 90 to 120 seconds. 4. Number of cycles : Up to 2 cycles <p>*Solder composition : Sn-3Ag-0.5Cu (Note 1) Values in this temperature profile are one of the recommendations.</p>
<p>2.Recommended manual soldering</p>	<p>Temperature of the soldering iron : 350°C max. Soldering time : 3 seconds max.</p>
<p>3.Recommended screen thickness and open area ratio (Pattern area ratio)</p>	<p>Standard thickness 0.1mm C: Stand-off type Opening ratio : Lead 100%, ground 100% None: Standard type Opening ratio : Lead 60%, ground 100%</p>
<p>4.Board warpage</p>	<p>Maximum of 0.02mm at the connector center, with both ends of the connector as reference points.</p>
<p>5.Cleaning conditions</p>	<p>IPA (Isopropyl Alcohol) cleaning is permitted. (Cleaning is not recommended as it may change the feel of the mating and un-mating of the connector. Please contact your Hirose sales representative for information if you plan to use any other cleaning agents.)</p>

◆ Precautions

Precautions

■ Mating

Mate the plug with receptacle by pressing straight against the entire plug surface.
Do NOT mate the plug while holding by the terminated cable.

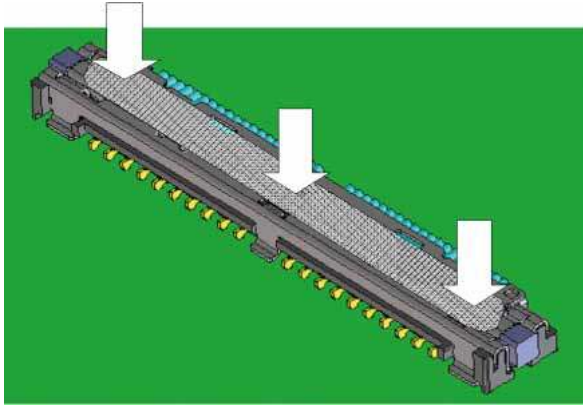

■ Un-mating

Use a dedicated extraction tool to un-mate the plug.
Insert the tool under either end of the plug and pull straight up as illustrated.

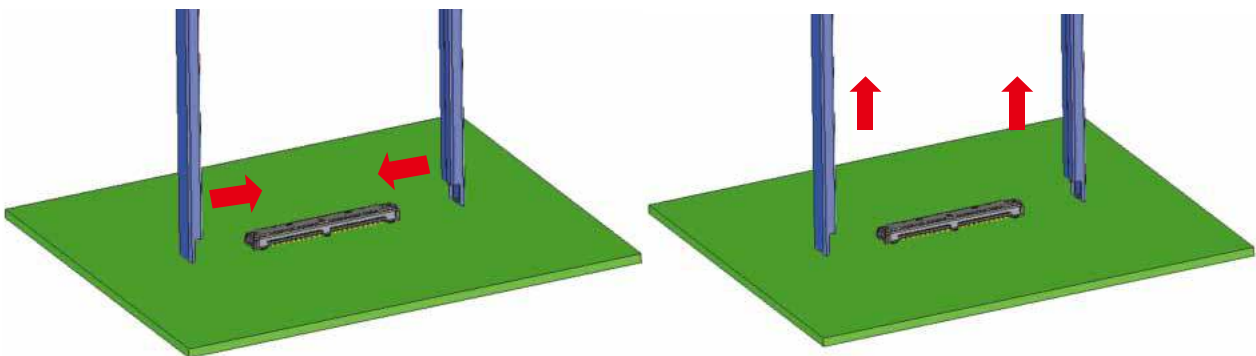

- Do not mate / un-mate the connectors when receptacle is not mounted on the board.
- In the manual soldering process, don't carry out the flux coating which will cause a flux blister on the connector.
- Excessive scoop insertion or extraction may result in damage.

USA:

HIROSE ELECTRIC (U.S.A.), INC. HEADQUARTERS CHICAGO OFFICE
2300 Warrenville Road, Suite 150,
Downers Grove, IL 60515
Phone : +1-630-282-6700
<http://www.hirose.com/us/>

USA:

HIROSE ELECTRIC (U.S.A.), INC. SAN JOSE OFFICE
2841 Junction Ave, Suite 200
San Jose, CA. 95134
Phone : +1-408-253-9640
Fax : +1-408-253-9641
<http://www.hirose.com/us/>

USA:

HIROSE ELECTRIC (U.S.A.), INC. DETROIT OFFICE (AUTOMOTIVE)
17197 N. Laurel Park Drive, Suite 253,
Livonia, MI 48152
Phone : +1-734-542-9963
Fax : +1-734-542-9964
<http://www.hirose.com/us/>

USA:

HIROSE ELECTRIC (U.S.A.), INC. BOSTON OFFICE
300 Brickstone Square Suite 201,
Andover, MA 01810
Phone : +1-978-662-5255

THE NETHERLANDS:

HIROSE ELECTRIC EUROPE B.V.
Hogehillweg #8 1101 CC Amsterdam Z-0
Phone : +31-20-6557460
Fax : +31-20-6557469
<http://www.hirose.com/eu/>

GERMANY:

HIROSE ELECTRIC EUROPE B.V. GERMAN BRANCH
Schoenbergstr. 20, 73760 ostfildern
Phone : +49-711-456002-1
Fax : +49-711-456002-299
<http://www.hirose.com/eu/>

GERMANY:

HIROSE ELECTRIC EUROPE B.V. NUREMBERG OFFICE
Neumeyerstrasse 22-26, 90411 Nurnberg
Phone : +49-911 32 68 89 63
Fax : +49-911 32 68 89 69
<http://www.hirose.com/eu/>

GERMANY:

HIROSE ELECTRIC EUROPE B.V. HANOVER OFFICE
Bayernstr. 3, Haus C 30855 Langenhagen, Germany
Phone : +49-511 97 82 61 30
Fax : +49-511 97 82 61 35
<http://www.hirose.com/eu/>

FRANCE:

HIROSE ELECTRIC EUROPE B.V. PARIS OFFICE
Regus La Garenne Colombes, Place de La Belgique,
71 Boulevard National La Garenne Colombes, 92250, France
Phone : +33 (0) 1 7082 3170
Fax : +33 (1) 7082 3101
<http://www.hirose.com/eu/>

UNITED KINGDOM:

HIROSE ELECTRIC EUROPE BV (UK BRANCH)
4 Newton Court, Kelvin Drive, Knowlhill,
Milton Keynes, MK5 8NH
Phone : +44-1908 202050
Fax : +44-1908 202058
<http://www.hirose.com/eu/>

CHINA:

HIROSE ELECTRIC (SHANGHAI) CO., LTD.
18, Enterprise Center Tower 2, 209# Gong He
Road, Jing'an District, Shanghai, CHINA 200070
Phone : +86-21-6391-3355
Fax : +86-21-6391-3335
<http://www.hirose.com/cn/>

CHINA:

HIROSE ELECTRIC (SHANGHAI) CO.,LTD. BEIJING BRANCH
A1001, Ocean International Center, Building 56# East 4th
Ring Middle Road, ChaoYang District, Beijing, 100025
Phone : +86-10-5165-9332
Fax : +86-10-5908-1381
<http://www.hirose.com/cn/>

CHINA:

HIROSE ELECTRIC TECHNOLOGIES (SHENZHEN) CO., LTD.
Room 09-13, 19/F, Office Tower Shun Hing Square, Di Wang Commercial Centre,
5002 Shen Nan Dong Road, Shenzhen City, Guangdong Province, 518008
Phone : +86-755-8207-0851
Fax : +86-755-8207-0873
<http://www.hirose.com/cn/>

HONG KONG:

HIROSE ELECTRIC HONGKONG TRADING CO., LTD.
Room 1001, West Wing, Tsim Sha Tsui Centre, 66
Mody Road, Tsim Sha Tsui East, Kowloon, Hong Kong
Phone : +852-2803-5338
Fax : +852-2591-6560
<http://www.hirose.com/hk/>

TAIWAN:

HIROSE ELECTRIC TAIWAN CO., LTD.
103 8F, No.87, Zhengzhou Rd., Taipei
Phone : +886-2-2555-7377
Fax : +886-2-2555-7350
<http://www.hirose.com/tw/>

KOREA:

HIROSE KOREA CO.,LTD.
143, Gongdan 1-daero, Siheung-si,
Gyeonggi-do, 15084, Korea
Phone : +82-31-496-7000
Fax : +82-31-496-7100
<http://www.hirose.co.kr/>

SINGAPORE:

HIROSE ELECTRIC SINGAPORE PTE. LTD.
03, Anson Road, #20-01, Springleaf Tower,
Singapore 079909
Phone : +65-6324-6113
Fax : +65-6324-6123
<http://www.hirose.com/sg/>

INDIA:

HIROSE ELECTRIC SINGAPORE PTE. LTD. DELHI LIAISON OFFICE
Office NO.552, Regus-Green Boulevard, Level5, Tower C,
Sec62, Plot B-9A, Block B, Noida, 201301, Uttar Pradesh, India
Phone : +91-12-660-8018
Fax : +91-120-4804949
<http://www.hirose.com/sg/>

INDIA:

HIROSE ELECTRIC SINGAPORE PTE. LTD. BANGALORE LIAISON OFFICE
Unit No-403, 4th Floor, No-84, Barton Centre, Mahatma
Gandhi (MG) Road, Bangalore 560 001, Karnataka, India
Phone : +91-80-4120 1907
Fax : +91-80-4120 9908
<http://www.hirose.com/sg/>

MALAYSIA:

PENANG REPRESENTATIVE OFFICE
73-3-1, Ideal@The One, Jalan Mahsuri, Bayan
Lepas Penang, 11950, Malaysia
Phone : +604-648-5536
<http://www.hirose.com/sg/>

THAILAND:

BANGKOK OFFICE (REPRESENTATIVE OFFICE)
Unit 4703, 47th FL., 1 Empire Tower, South Sathorn
Road, Yannawa, Sathorn, Bangkok 10120 Thailand
Phone : +66-2-686-1255
Fax : +66-2-686-3433
<http://www.hirose.com/sg/>



HIROSE ELECTRIC CO.,LTD.

2-6-3,Nakagawa Chuoh,Tsuzuki-Ku,Yokohama-Shi 224-8540,JAPAN
TEL: +81-45-620-3526 Fax: +81-45-591-3726
<http://www.hirose.com>
<http://www.hirose-connectors.com>