

THIS COPY IS PROVIDED ON A RESTRICTED BASIS AND IS NOT TO BE USED IN ANY WAY DETRIMENTAL TO THE INTERESTS OF PANDUIT CORP.

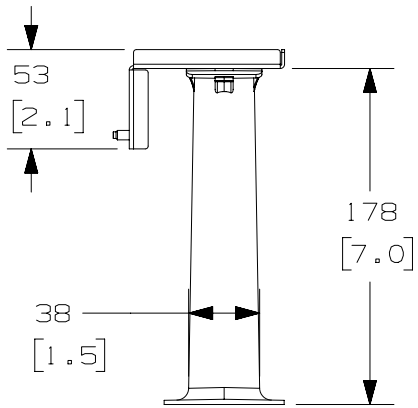

PANDUIT PART NO.	WEIGHT
NERSS	1.66 LBS/EACH 754.7 g/EACH

NOTES:

- VISIT OUR ON-LINE CATALOG AT [WWW.PANDUIT.COM](http://WWW.PANDUIT.COM) FOR A LIST OF CURRENT PARTS APPLICABLE FOR USE WITH THIS PRODUCT.
- PRIMARY DIMENSIONS ARE IN MILLIMETERS.
- PARTS SUPPLIED:
  - (1)-RIGHT SIDE END SPOOL BRACKET
  - (1)-LEFT SIDE END SPOOL BRACKET
  - (2)-MOLDED SPOOLS (PN: PRSP7)
  - (1)-HARDWARE KIT
    - (4) M5 X 0.8mm SCREWS
  - (1)-INSTRUCTION SHEET (NOT SHOWN)
- MOUNTS TO SIDE OF CABINET POSTS.

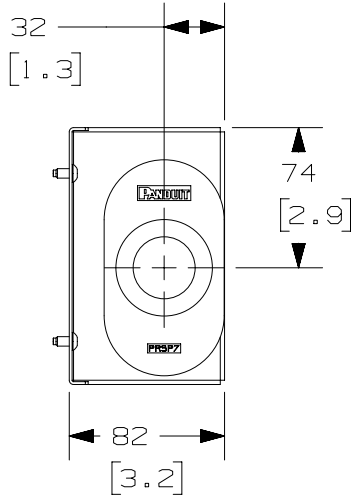

SEE SHEET 2 FOR DETAIL VIEWS OF LEFT SIDE END SPOOL BRACKET

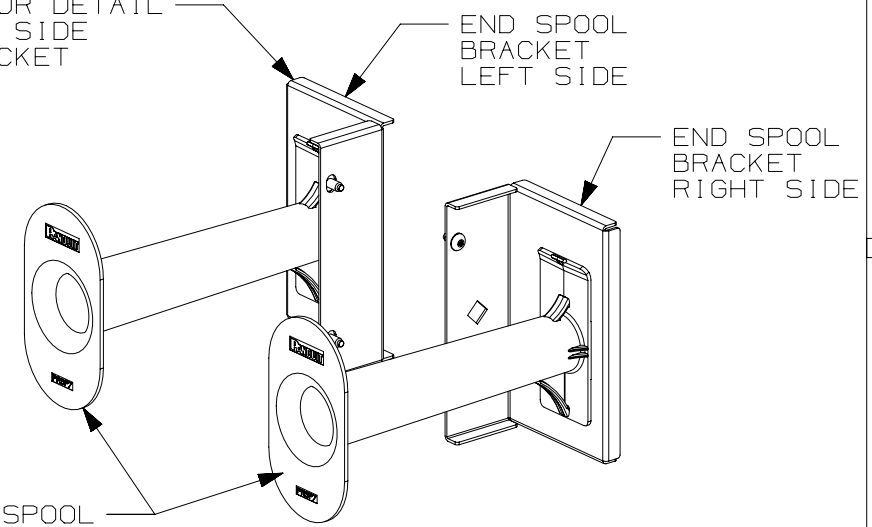
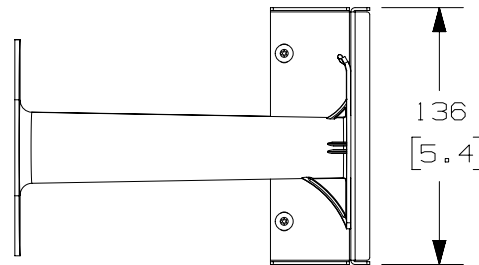

REV	DATE	BY	CHK	APR	DESCRIPTION	ECN
00B	2/15/19	MEX-JAGC	RAMA	ELE	UPDATED DRAWING TEMPLATE AND NOTES. ADDED P/N CHART	V09001WE/00
00A	6/17/13	PBS	RAMA	JDWE	RELEASED TO PRODUCTION	13V377GW

TITLE		NETWORK END OF ROW SLACK SPOOL (NERSS)	
		CONTROL DRAWING	
ITEM REVISION NAME		13V377GW/00	
DATASET FILE NAME		13V377GW_DC/00B	
MATERIAL:		N/A	
DRAWING NUMBER:		13V377GW-DC	
DRAWN BY	DATE	CHK	SCALE
PBS	6/17/13	RAMA	NONE
SHT 1 OF 2		A	

D10100DA/20

THIS COPY IS PROVIDED ON A RESTRICTED BASIS AND IS NOT TO BE USED IN ANY WAY DETRIMENTAL TO THE INTERESTS OF PANDUIT CORP.

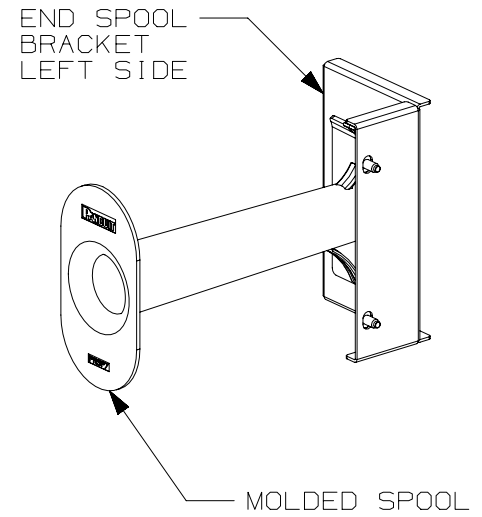
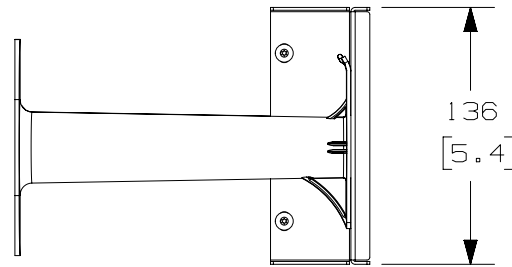
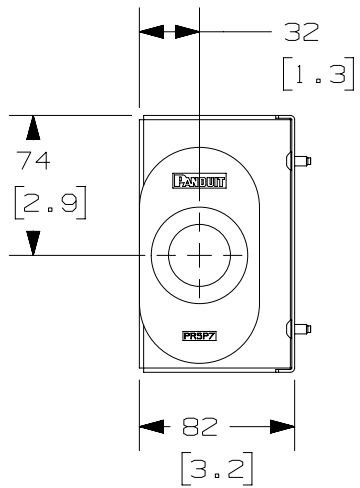
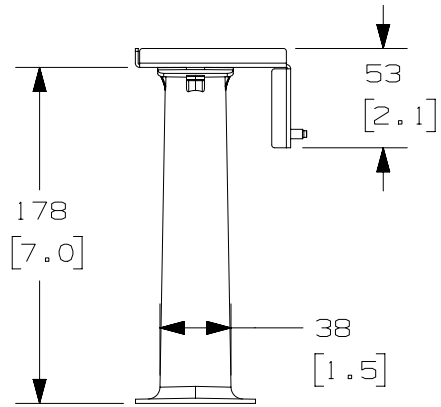

REV	DATE	BY	CHK	APR	DESCRIPTION	ECN
00B	2/15/19	MEX-JAGC	RAMA	ELE	SEE SHEET 1 OF 2 FOR REVISIONS	V09001WE/00
00A	6/17/13	PBS	RAMA	JDWE	SEE SHEET 1 OF 2 FOR REVISIONS	13V377GW

TITLE						NETWORK END OF ROW SLACK SPOOL (NERSS)	
						CONTROL DRAWING	
ITEM REVISION NAME						13V377GW/00	
DATASET FILE NAME						13V377GW_DC/00B	
						MATERIAL:	
						N/A	
						DRAWING NUMBER:	
						13V377GW-DC	
DRAWN BY		DATE		CHK		SCALE	
PBS		6/17/19		RAMA		NONE	
THIRD ANGLE PROJECTION						SHT 2 OF 2	
						SIZE	
						A	

DI10100DA/20