

4

3

2

1

© 20 BY -

TE Connectivity Ltd. company. All Rights Reserved.

REVISIONS

| P | LTR | DESCRIPTION | DATE | DWN | APVD |
|----|-----|---|-----------|-----|------|
| A1 | | CURRENT RATING CORRECTED FROM 11A TO 15 A | 27JAN2020 | RK | PS |

NOTES:

- MATERIAL AND FINISH:
HOUSING : HIGH TEMPERATURE POLYAMIDE, UL94V-0
COLOR BLACK.
TERMINAL : COPPER ALLOY, TIN PLATED.
- MECHANICAL
MIN. PC BOARD HOLES DIAMETER : 1.6 mm
MAX. PC BOARD THICKNESS : 2.4 mm
- ELECTRICAL
MAX. VOLTAGE : 300 V
MAX CURRENT : 15 A
CONTACT RESISTANCE : <15 m Ohm
INSULATION RESISTANCE : >1000 M Ohm (500V DC)
- OPERATING TEMPERATURE RANGE: -40°C TO +105°C
- NOT CUMULATIVE TOLERANCE.
- PARTS ARE PACKED IN BOX.

| | | |
|--------|------------|-------------|
| 128.88 | 25 | 2-2342083-5 |
| 123.80 | 24 | 2-2342083-4 |
| 118.72 | 23 | 2-2342083-3 |
| 113.64 | 22 | 2-2342083-2 |
| 108.56 | 21 | 2-2342083-1 |
| 103.48 | 20 | 2-2342083-0 |
| 98.40 | 19 | 1-2342083-9 |
| 93.32 | 18 | 1-2342083-8 |
| 88.24 | 17 | 1-2342083-7 |
| 83.16 | 16 | 1-2342083-6 |
| 78.08 | 15 | 1-2342083-5 |
| 73.00 | 14 | 1-2342083-4 |
| 67.92 | 13 | 1-2342083-3 |
| 62.84 | 12 | 1-2342083-2 |
| 57.76 | 11 | 1-2342083-1 |
| 52.68 | 10 | 1-2342083-0 |
| 47.60 | 9 | 2342083-9 |
| 42.52 | 8 | 2342083-8 |
| 37.44 | 7 | 2342083-7 |
| 32.36 | 6 | 2342083-6 |
| 27.28 | 5 | 2342083-5 |
| 22.20 | 4 | 2342083-4 |
| 17.12 | 3 | 2342083-3 |
| 12.04 | 2 | 2342083-2 |
| DIM A | NO. OF POS | PART NUMBER |

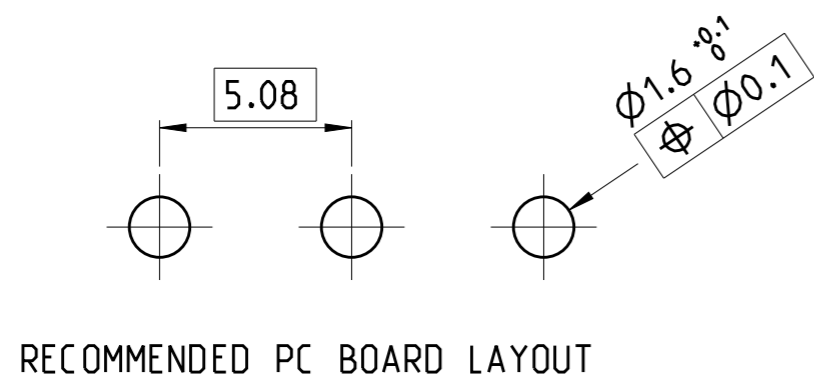
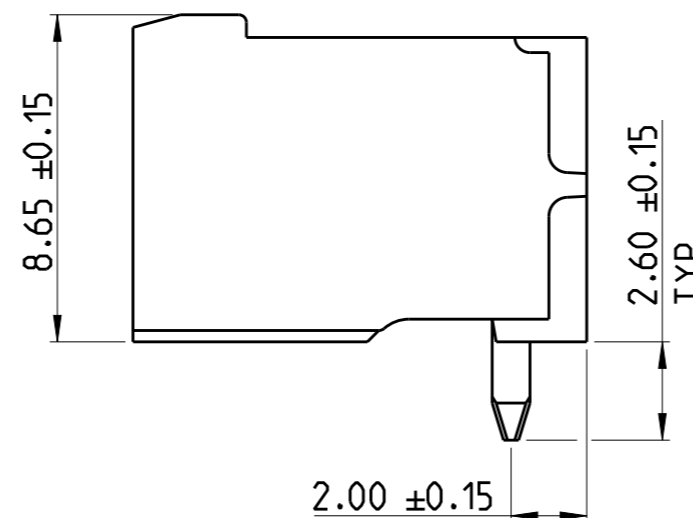
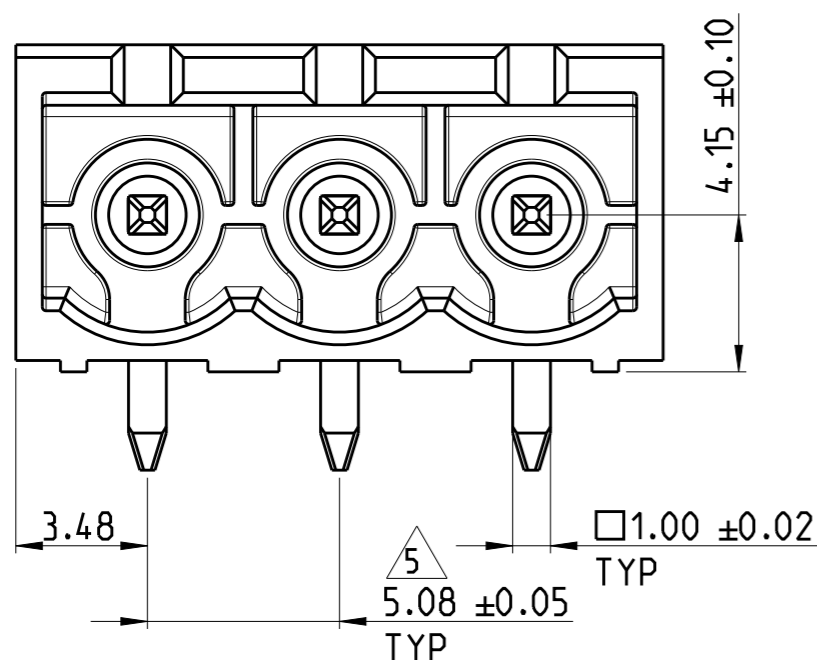
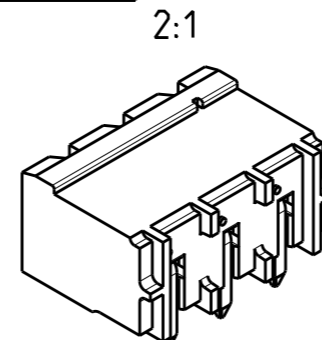
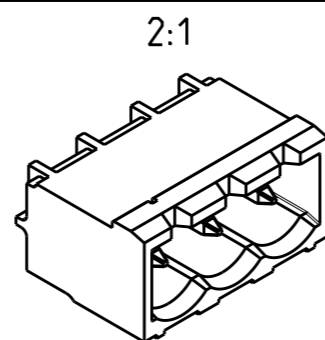
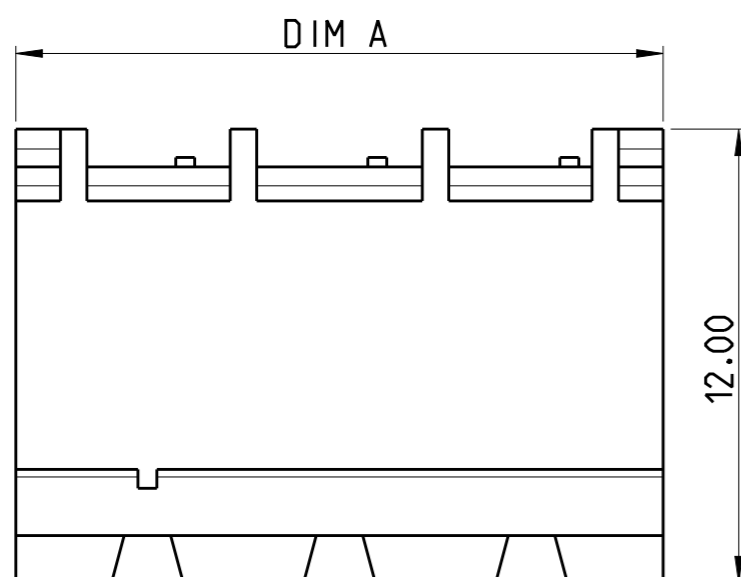

RECOMMENDED PC BOARD LAYOUT

THIS DRAWING IS A CONTROLLED DOCUMENT.

| DIMENSIONS: | TOLERANCES UNLESS OTHERWISE SPECIFIED: |
|-------------|--|
| mm | |
| | 0 PLC ±0.3 |
| | 1 PLC ±0.25 |
| | 2 PLC ±0.25 |
| | 3 PLC ±0.25 |
| | 4 PLC ±0.25 |
| | ANGLES ±2° |
| MATERIAL | FINISH |
| SEE NOTES | SEE NOTES |

| | |
|------------------|---------------|
| DWN | 17DEC 2018 |
| CHK | RAGHAVENDRA.K |
| CHK | KARTHIK.JK |
| APVD | 19DEC 2018 |
| APVD | PRASHANTH.S |
| PRODUCT SPEC | |
| APPLICATION SPEC | |
| WEIGHT | |
| CUSTOMER DRAWING | |

NAME
HEADER 90 DEG. HIGH TEMPERATURE,
5.08MM PITCH, TAIL LENGTH 2.6mm

| SIZE | CAGE CODE | DRAWING NO | RESTRICTED TO |
|-------|-----------|------------|---------------|
| A3 | 00779 | C-2342083 | |
| SCALE | SHEET | OF | REV |
| 5:1 | 1 | 1 | A1 |