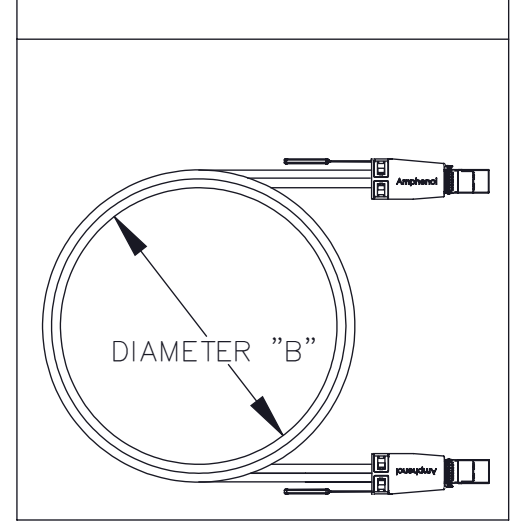

TABLE 1				
AHSP P/N	LENGTH "A"	ACD P/N	DIAMETER "B"	DESCRIPTION
NBCCDB-C102	2000 MM ±50 MM	CS-SASMINIHD2-002	7.0" ± 1.0"	MINISAS HD TO MINISAS HD 28AWG, 2M
NBCCDB-C103	3000 MM ±75 MM	CS-SASMINIHD2-003	7.0" ± 1.0"	MINISAS HD TO MINISAS HD 28AWG, 3M

REVISIONS						
ZONE	REV.	ECN NUMBER	DESCRIPTION	BY	DATE	APPROVED
	A	RGAO-21010302	NEW RELEASE	R.LI	12/04/2020	F.HONG
	B	RGAO-21020309	ADDED DESCRIPTION COLUMN TO TABLE 1.	N.ZENG	2/4/2021	F.HONG

TABLE 2	
ITEM No.	DESCRIPTION
1	28 AWG 4PR, BLACK, UL CL2 CSA FT4 75°C, AWM 75°C
2	PLUG, HDMSAS - REFERENCE SFF-8644
3	LABEL, WRAPPED - AHSP P/N & REV, DATE CODE, COUNTRY OF ORIGIN AND SERIAL NUMBER
4	LANYARD, HDMSAS, BLUE, UL 94V-0



BAGGED CABLE ASSY NOT TO SCALE

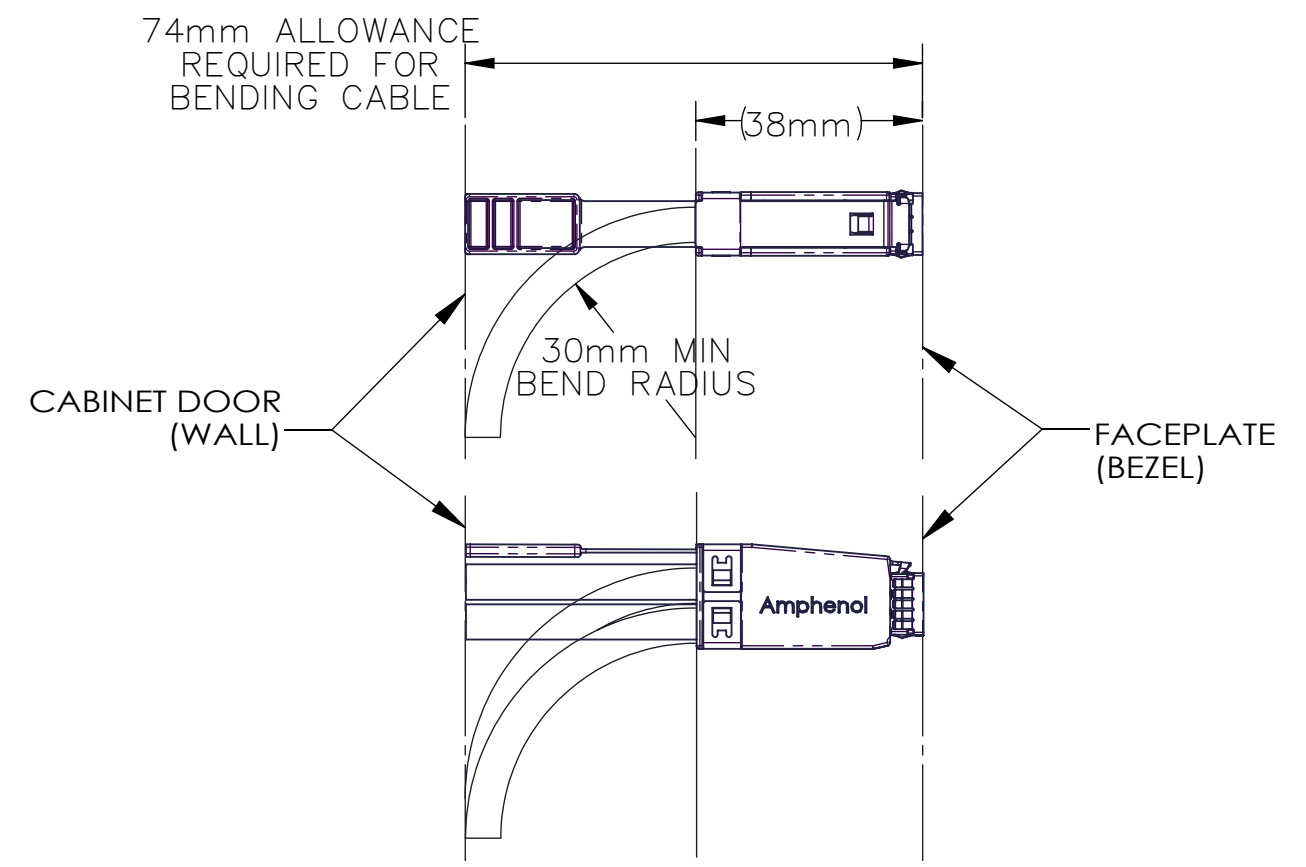
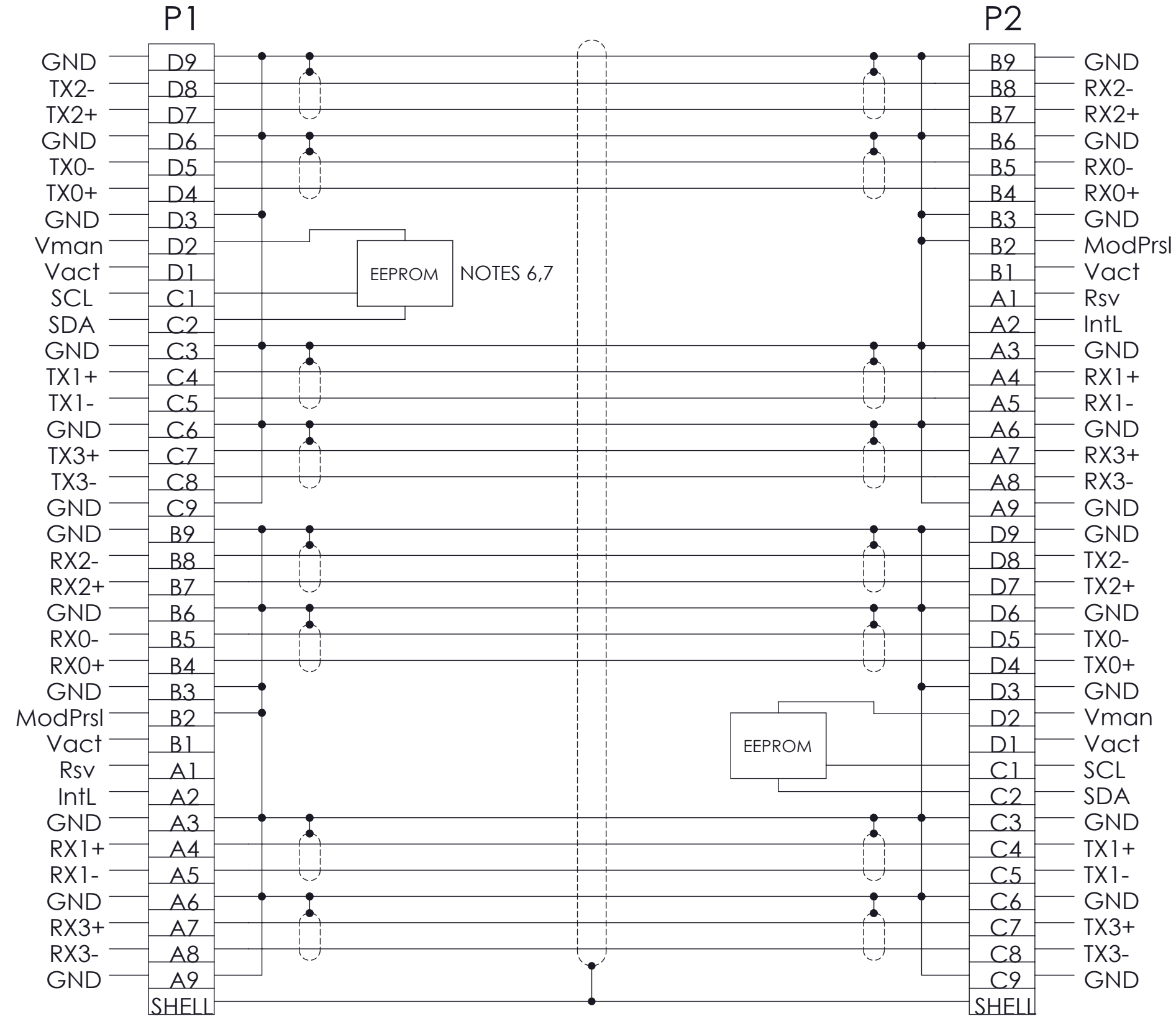
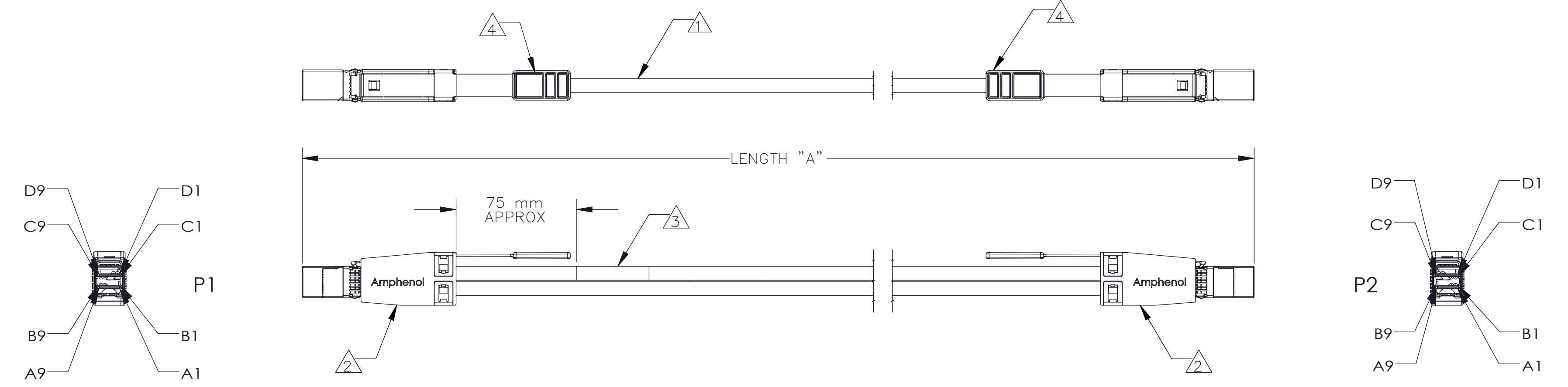

- THIS DRAWING IS RESERVED FOR AMPHENOL CABLES ON DEMAND (NO CUSTOMER DRAWING)..
- TEST COMPLETED ASSEMBLIES PER ACS-1189. TEST ASSEMBLIES AT 12.00 Gbps AND/OR PER AMPHENOL IOPS-4001 SPEC.
- UL LABEL MUST BE ON SHIPPING CARTON PER SUBJECT 764 OF THE UL COMPONENT WIRING HARNESS (ZPFW2) FILE #E86140. CSA LABEL MUST BE ON SHIPPING CARTON.
- PACKAGE COMPLETED ASSY IN AN APPROPRIATELY SIZED ANTI-STATIC BAG.
- INSTALL DUST COVER OVER EACH CONNECTOR PRIOR TO SHIPMENT TO CUSTOMER.
- EPROM CONTENT SHALL BE COMPLIANT WITH SFF-8636 AND SFF-8024 FOR SAS 3.0.
- CAUTION: ANTI-STATIC CONTROL MEASURES MUST BE OBSERVED DURING THE MANUFACTURE OF THIS ASSEMBLY.
- ALL MATERIALS USED IN THE MANUFACTURE OF THIS ASSEMBLY SHALL COMPLY WITH AMPHENOL REGULATED MATERIALS SPECIFICATION ACS-1152.

NOTES: UNLESS OTHERWISE SPECIFIED

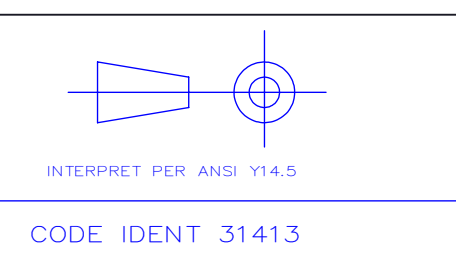

TOLERANCES		DWN 12/04/2020		Amphenol AHSP	
.00	± 0.010	CHK	R.LI	A Division of Amphenol Corporation	
.000	± .003	APVD	F.HONG	200 Innovative Way, Suite 201, Norwalk, Conn. 06850 (603) 876-3000	
.0000	± 0.0001	DATE	12/04/2020	TITLE	
ANGLES	± 1.0°	BY	W.ZHANG	CABLE ASSEMBLY, MINISAS HD TO MINISAS HD 4X, 28AWG,SAS 3.0,12Gbps	
UNLESS OTHERWISE SPECIFIED DIMENSIONS ARE IN INCHES					
CUSTOMER USE DRAWING				PART NO.	REV
				SEE TABLE 1	N/A
				DRAWING NO.	REV
				C-NBCCDB-C199	B
SIZE	D	SCALE	1:1	Sheet1	OF 1