

Module LoRa868

SKU:M029

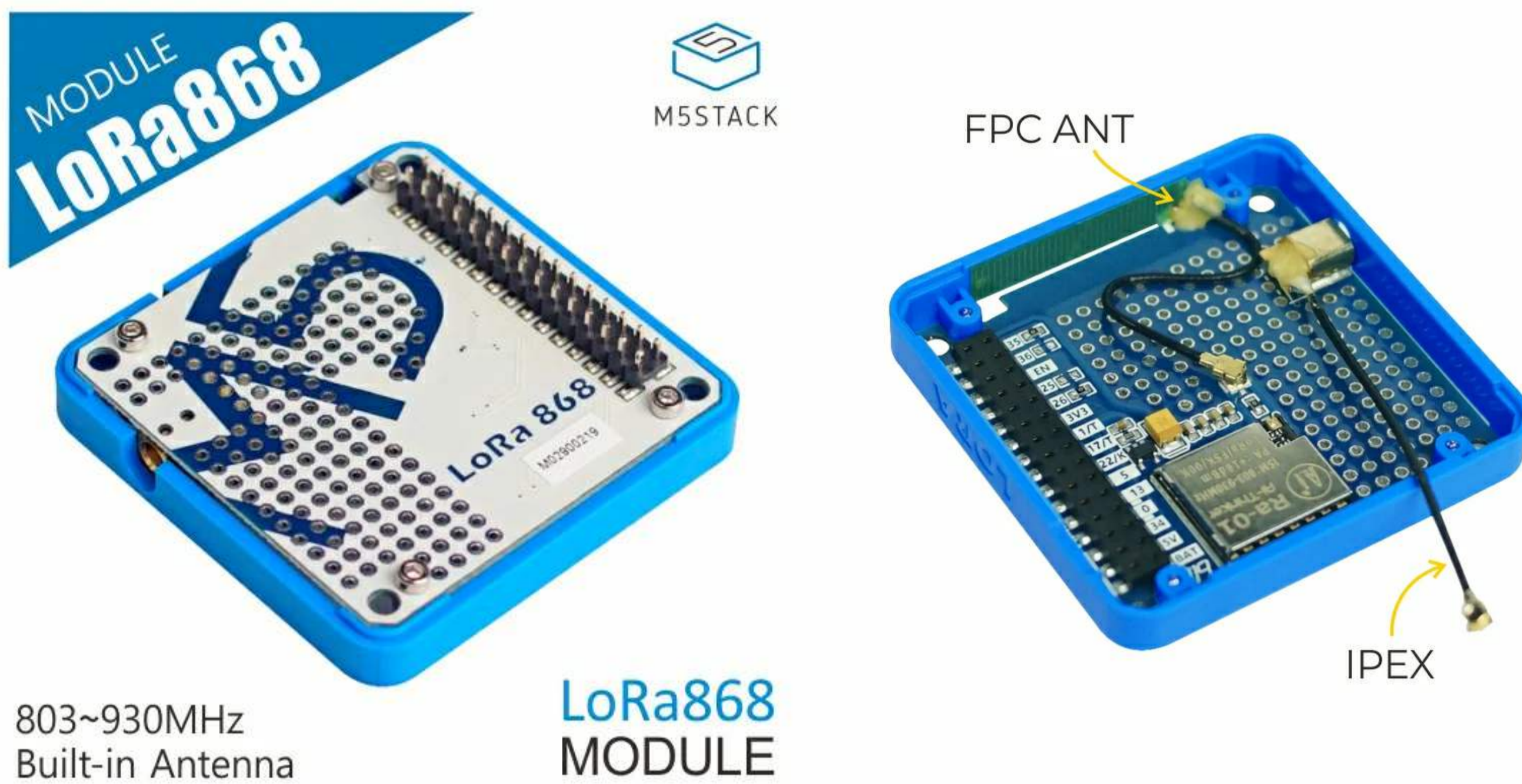

Description

LoRa868 is a LoRa communication module in the M5Stack stack module series (working frequency is 868MHz). A certain expansion space is reserved on the module, which defeats you for more functional design. For wireless communication or projects with more customized elements, the LoRa868 module will be a suitable choice.

Product Features

- LoRa Module: Ra-01H
- Communication Protocol: SPI
- Universal Perfboard
- Working Frequency: 803~930 MHz
- Supports: FSK, GFSK, MSK, GMSK, LoRa™ and OOK modulation modes
- Receive sensitivity: lowest to -141 dBm
- Programmable bit rate up to 300Kbps
- Built-in FPC Antenna
- External IPX Antenna connector
- Program platform: Arduino

Include

- 1x M5Stack LoRa868 Module

Applications

- Remote electricity meter reading
- Home automation
- Remote irrigation system

Specification

Resources	Parameter
Net weight	14g
Gross weight	24g
Product Size	54.2*54.2*13mm
Package Size	60*57*17mm

Related Link

- [LoRa Info \(LoRa\)](#)
- [LoRaWAN Regional Parameters](#)

EasyLoader

EasyLoader is a concise and fast program writer, which has a built-in case program related to the product. It can be burned to the main control by simple steps to perform a series of function verification.

[Download Windows Version Easyloader](#)

[Download MacOS Version Easyloader](#)



Description:

Two devices will send and receive messages from each other.

Example

Arduino IDE

These are the point-to-point communication [examples](#) between two LORA868 modules. The LoRa nodes send and receive messages.

- Blue string indicates sending succeed.
- Yellow string display the received messages.
- Red string indicates initialization failed.

Schematic

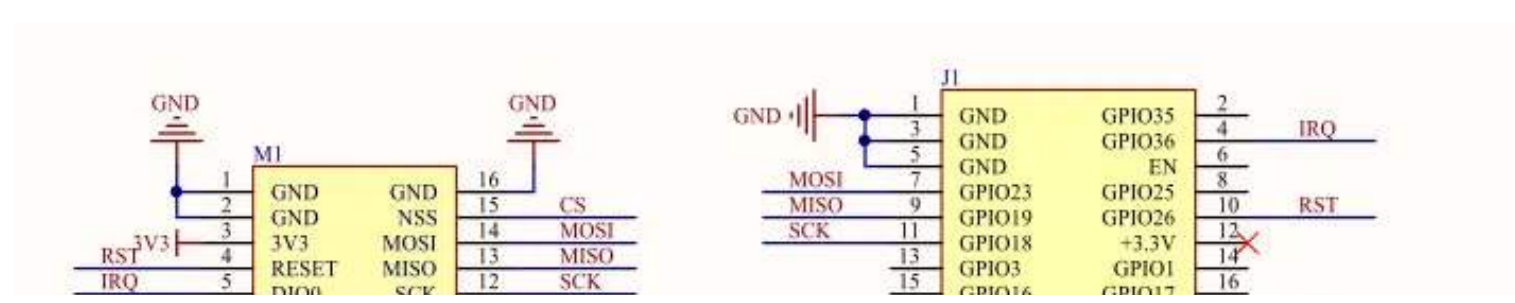

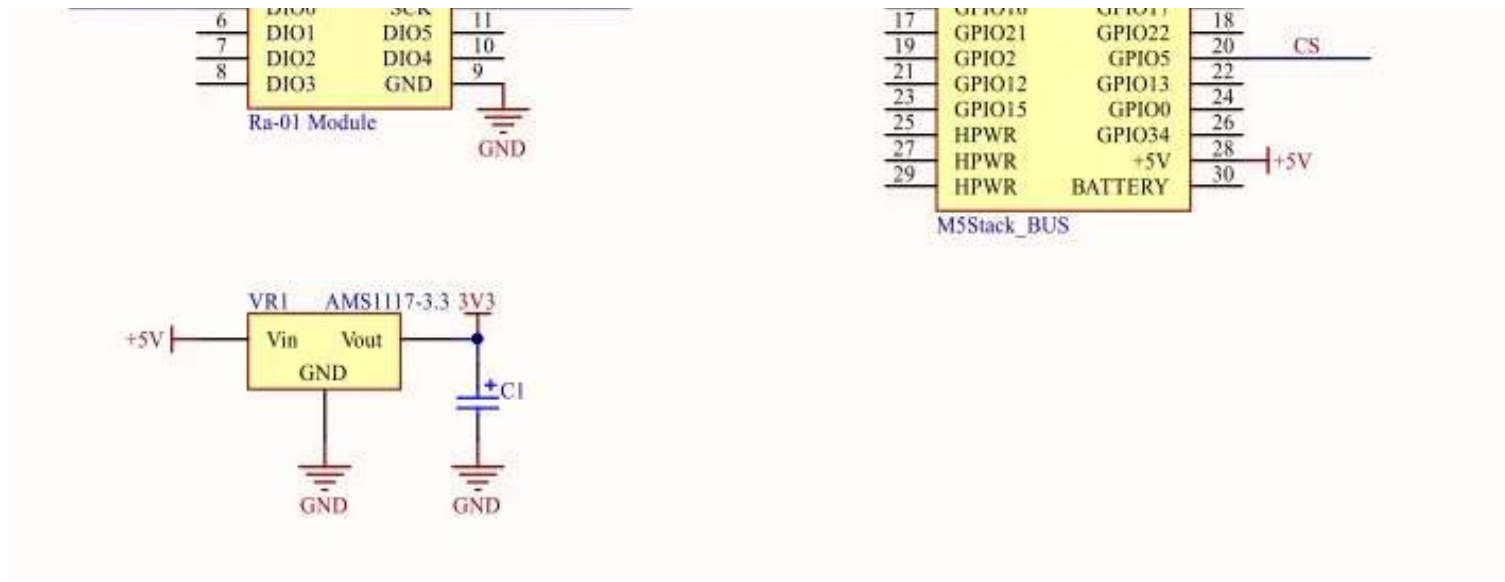

MBUS PinMap

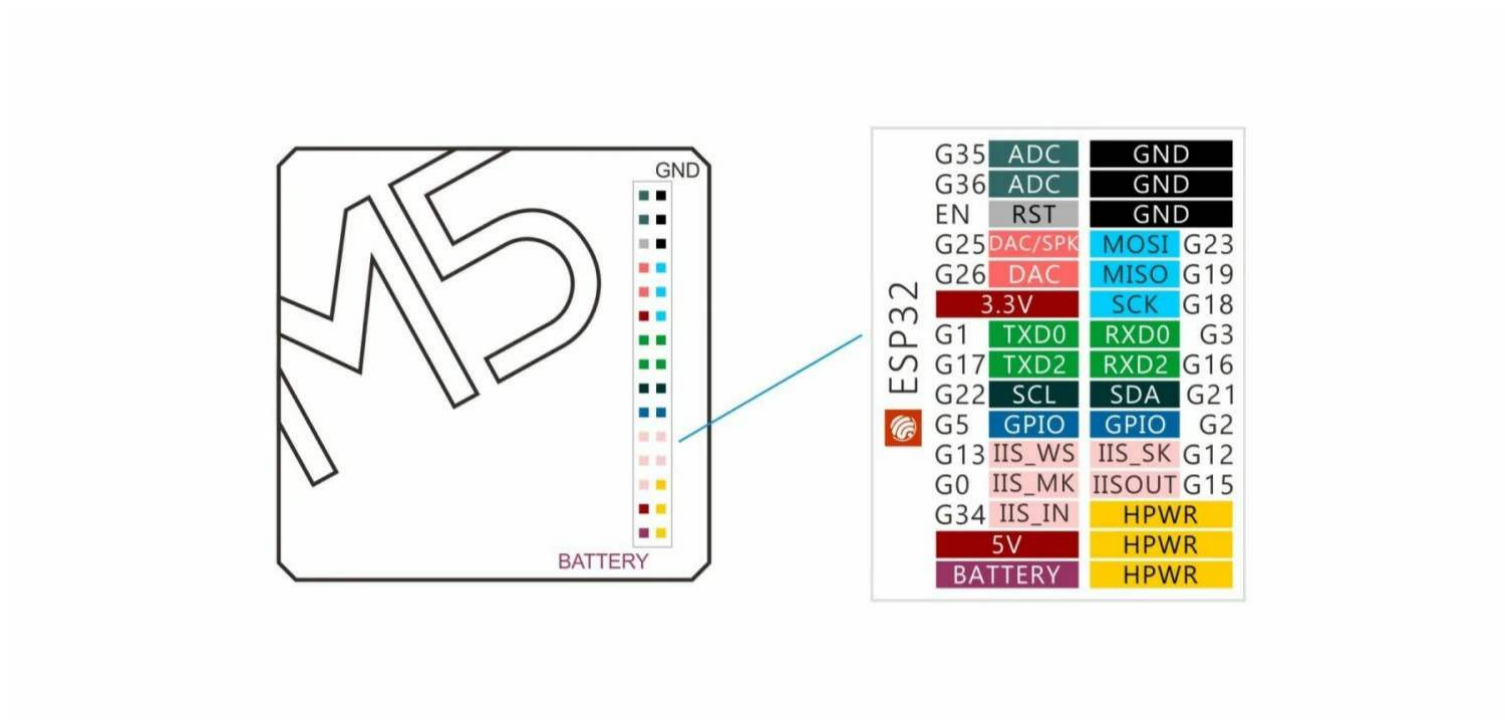

Last updated: 2020-12-28