

REVISIONS							
LOC	Q1ST	P	F	ZONE	LTR	DESCRIPTION	
CM	53					0 RELEASED PER PR CM 93-69	
						DATE	APPD
						7-14-93	LS RS

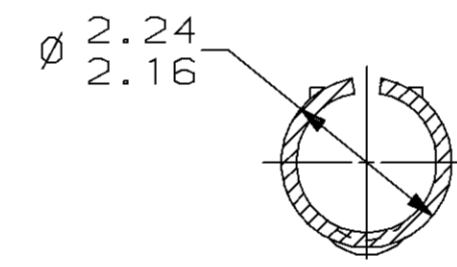

SECTION A-A
SCALE 10:1

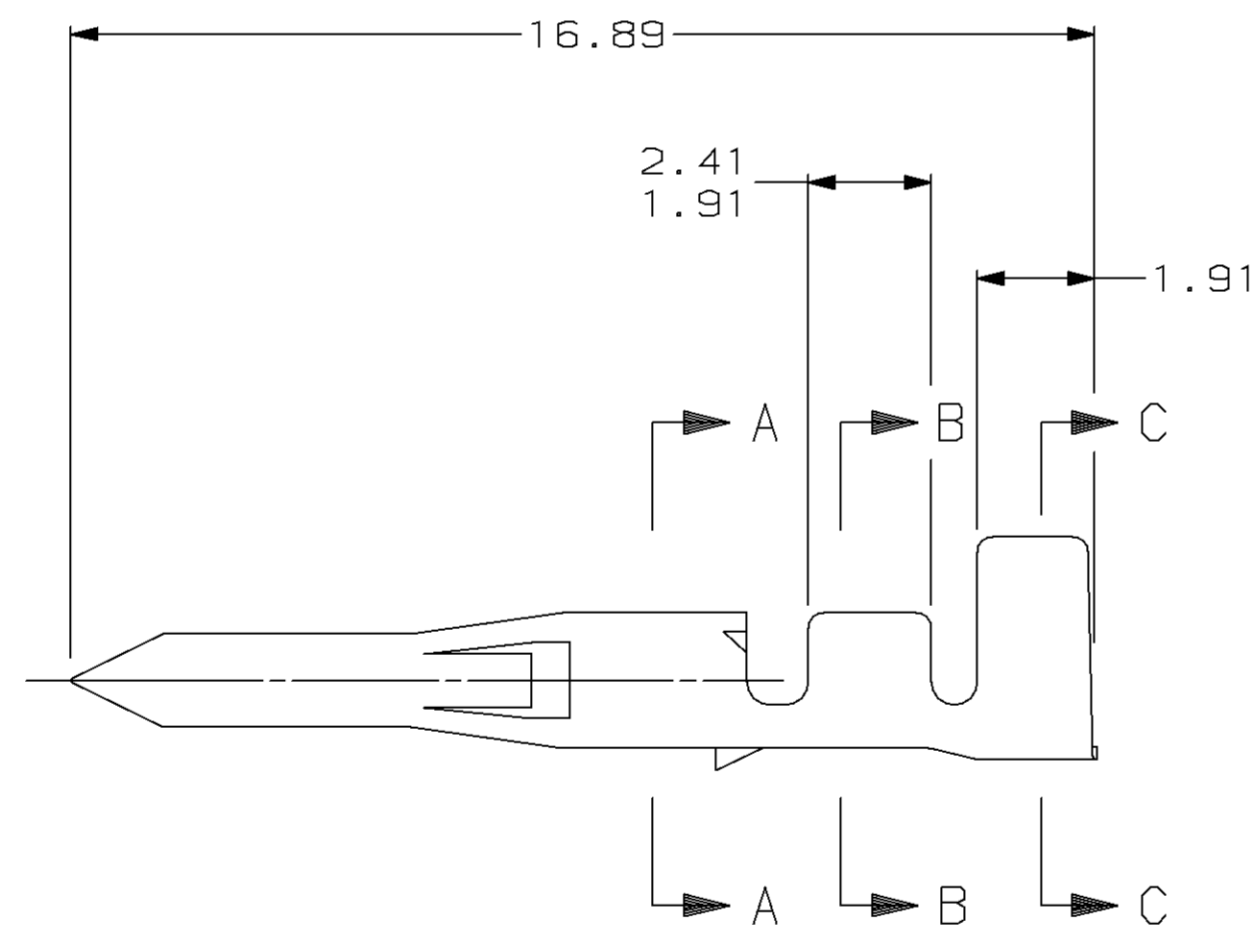
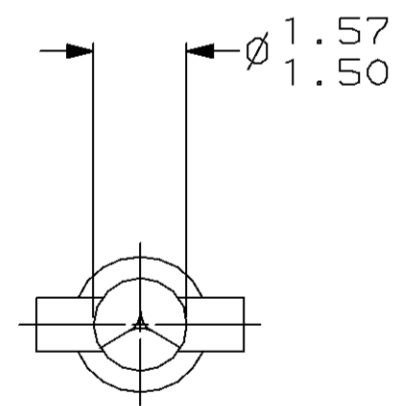
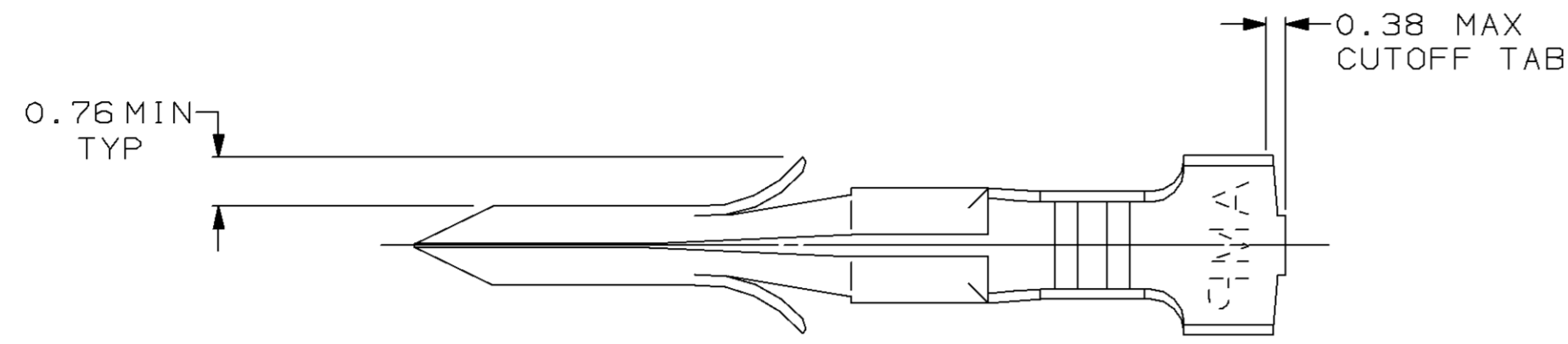
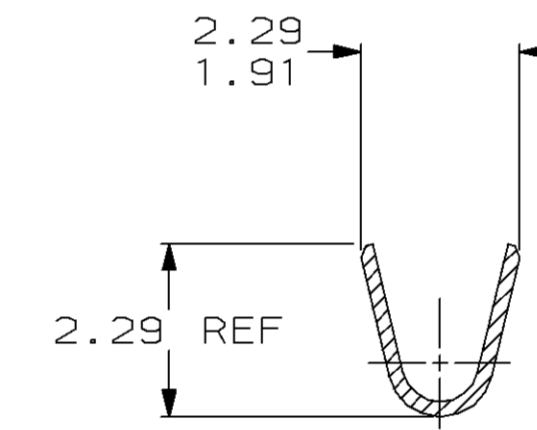

SECTION B-B
SCALE 10:1

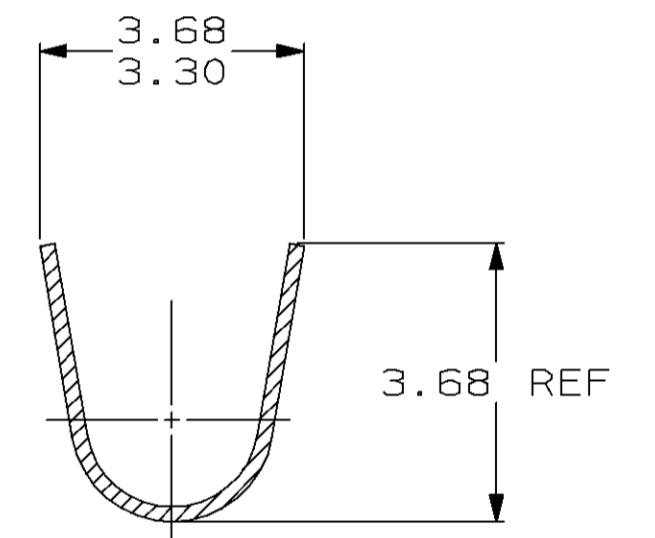

SECTION C-C
SCALE 10:1

MM	IN	MM	IN	MM	IN
1.50	.059	2.41	.095		
1.27	.050	2.29	.090		
0.76	.030	2.24	.088	16.89	.665
0.38	.015	2.16	.085	3.68	.145
0.20	.008	1.91	.075	3.30	.130
0.13	.005	1.57	.062	2.79	.110
MM	IN	MM	IN	MM	IN

CONVERSION TABLE

METRIC

PRE-TIN	0.20 BRASS	1.27 - 2.79	0.2 - 0.9 mm ² (24-18 AWG)	794017-1
FINISH	MATERIAL	INSULATION DIAMETER	WIRE RANGE	PART NO
DO NOT SCALE PRINT. UNLESS SPECIFIED DIMENSIONS IN mm TOLERANCES ON: 2 PLC DEC ± 0.13 3 PLC DEC ± - ANGLES ± -	DR 7-14-93 L. SMITH	AMP Incorporated Harrisburg, PA 17105-3608		
MATERIAL	CHK 7-14-93 R. SWING			
SEE TABLE	APPD 7-15-93 C. CASH	NAME .062 PIN, LOOSE PIECE, COMMERCIAL PIN AND SOCKET		
FINISH	APPD 7-15-93 C. CASH	SIZE	CAGE CODE	DRAWING NO
SEE TABLE	APPLICATION SPEC	Ø 00779		794017
	WEIGHT -	SCALE	8:1	SHEET 1 OF 1

CUSTOMER DRAWING