

**FEATURES:**

- The IDT72V81 is equivalent to two IDT72V01 - 512 x 9 FIFOs
- The IDT72V82 is equivalent to two IDT72V02 - 1,024 x 9 FIFOs
- The IDT72V83 is equivalent to two IDT72V03 - 2,048 x 9 FIFOs
- The IDT72V84 is equivalent to two IDT72V04 - 4,096 x 9 FIFOs
- The IDT72V85 is equivalent to two IDT72V05 - 8,192 x 9 FIFOs
- Low power consumption
  - Active: 330 mW (max.)
  - Power-down: 18 mW (max.)
- Ultra high speed—15 ns access time
- Asynchronous and simultaneous read and write
- Offers optimal combination of data capacity, small foot print and functional flexibility
- Ideal for bidirectional, width expansion, depth expansion, bus-matching, and data sorting applications
- Status Flags: Empty, Half-Full, Full
- Auto-retransmit capability
- High-performance CMOS™ technology
- Space-saving TSSOP package
- Industrial temperature range (–40°C to +85°C) is available
- Green parts available, see ordering information

**DESCRIPTION:**

The IDT72V81/72V82/72V83/72V84/72V85 are dual-FIFO memories that load and empty data on a first-in/first-out basis. These devices are functional and compatible to two IDT72V01/72V02/72V03/72V04/72V05 FIFOs in a single package with all associated control, data, and flag lines assigned to separate pins. The devices use Full and Empty flags to prevent data overflow and underflow and expansion logic to allow for unlimited expansion capability in both word size and depth.

The reads and writes are internally sequential through the use of ring pointers, with no address information required to load and unload data. Data is toggled in and out of the devices through the use of the Write ( $\overline{W}$ ) and Read ( $\overline{R}$ ) pins.

The devices utilize a 9-bit wide data array to allow for control and parity bits at the user's option. This feature is especially useful in data communications applications where it is necessary to use a parity bit for transmission/reception error checking. It also features a Retransmit ( $\overline{RT}$ ) capability that allows for reset of the read pointer to its initial position when  $\overline{RT}$  is pulsed low to allow for retransmission from the beginning of data. A Half-Full Flag is available in the single device mode and width expansion modes.

These FIFOs are fabricated using high-speed CMOS technology. They are designed for those applications requiring asynchronous and simultaneous read/writes in multiprocessing and rate buffer applications.

**FUNCTIONAL BLOCK DIAGRAM**

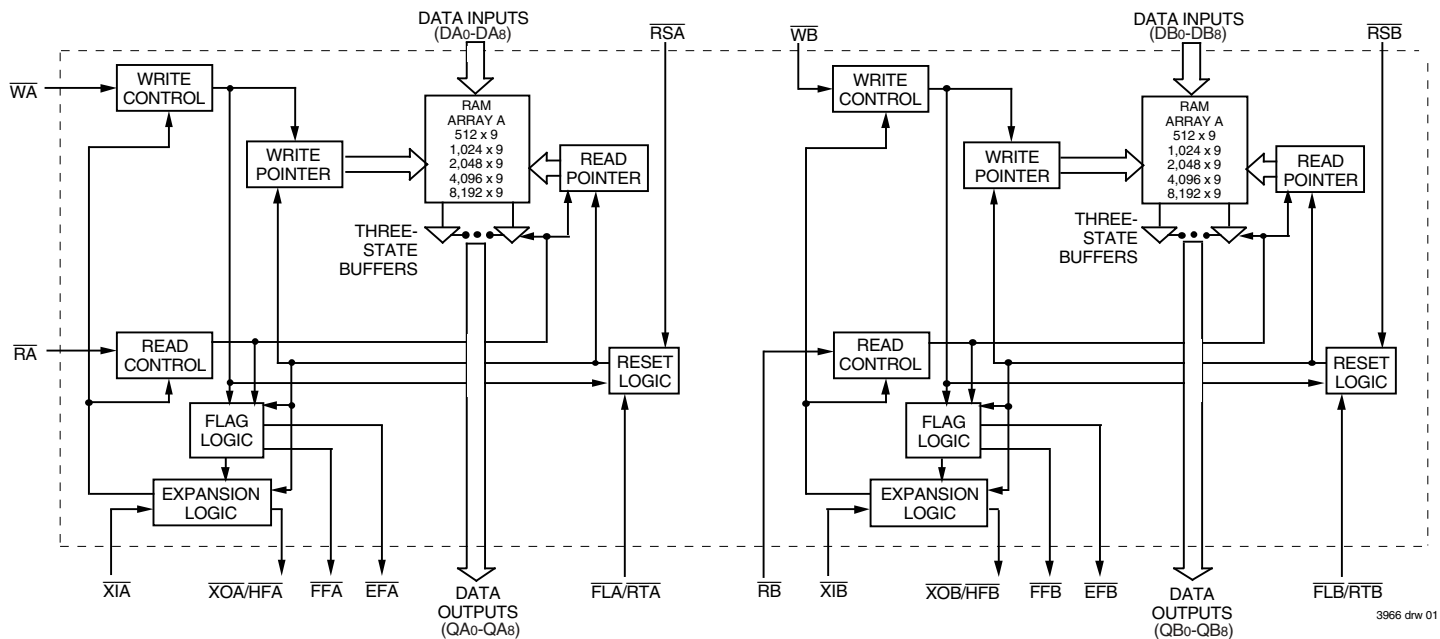

## PIN CONFIGURATION

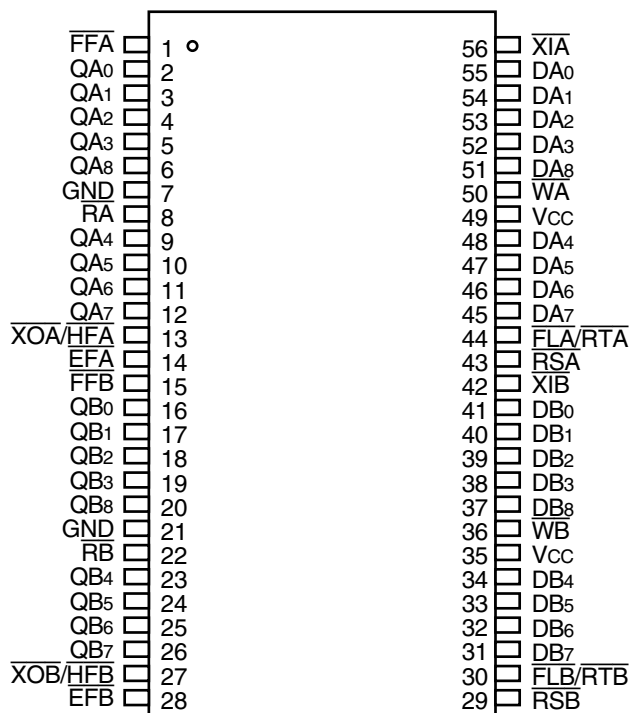

3966 drw 02

TSSOP (SO56-2, order code: PA)  
TOP VIEW

## ABSOLUTE MAXIMUM RATINGS

Symbol	Rating	Com'l & Ind'l	Unit
VTERM	Terminal Voltage with Respect to GND	-0.5 to +7.0	V
TSTG	Storage Temperature	-55 to +125	°C
IOUT	DC Output Current	-50 to +50	mA

NOTE:

- Stresses greater than those listed under ABSOLUTE MAXIMUM RATINGS may cause permanent damage to the device. This is a stress rating only and functional operation of the device at these or any other conditions above those indicated in the operational sections of this specification is not implied. Exposure to absolute maximum rating conditions for extended periods may affect reliability.

## RECOMMENDED DC OPERATING CONDITIONS

Symbol	Parameter	Min.	Typ.	Max.	Unit
VCC	Supply Voltage	3.0	3.3	3.6	V
GND	Supply Voltage	0	0	0	V
V <sub>IH</sub> <sup>(1)</sup>	Input High Voltage	2.0	—	V <sub>CC</sub> +0.5	V
V <sub>IL</sub> <sup>(2)</sup>	Input Low Voltage	—	—	0.8	V
T <sub>A</sub>	Operating Temperature Commercial	0	—	70	°C
T <sub>A</sub>	Operating Temperature Industrial	-40	—	85	°C

NOTES:

- For  $\overline{RT}/\overline{RS}/\overline{XI}$  input, V<sub>IH</sub> = 2.6V (commercial and industrial).
- 1.5V undershoots are allowed for 10ns once per cycle

## CAPACITANCE (T<sub>A</sub> = +25°C, f = 1.0 MHz)

Symbol	Parameter <sup>(1)</sup>	Condition	Max.	Unit
C <sub>IN</sub>	Input Capacitance	V <sub>IN</sub> = 0V	8	pF
C <sub>OUT</sub>	Output Capacitance	V <sub>OUT</sub> = 0V	8	pF

NOTE:

- Characterized values, not currently tested.

## DC ELECTRICAL CHARACTERISTICS<sup>(1)</sup>

(Commercial: V<sub>CC</sub> = 3.3V±0.3V, T<sub>A</sub> = 0°C to +70°C;

Industrial: V<sub>CC</sub> = 3.3V±0.3V, T<sub>A</sub> = -40°C to +85°C)

Symbol	Parameter	Commercial t <sub>A</sub> = 15, 20 ns		Industrial t <sub>A</sub> = 20 ns		Unit
		Min.	Max.	Min.	Max.	
I <sub>LI</sub> <sup>(1)</sup>	Input Leakage Current (Any Input)	-1	1	-1	1	μA
I <sub>LO</sub> <sup>(2)</sup>	Output Leakage Current	-10	10	-10	10	μA
V <sub>OH</sub>	Output Logic "1" Voltage I <sub>OH</sub> = -2mA	2.4	—	2.4	—	V
V <sub>OL</sub>	Output Logic "0" Voltage I <sub>OL</sub> = 8mA	—	0.4	—	0.4	V
I <sub>CC1</sub> <sup>(3,4)</sup>	Active Power Supply Current (both FIFOs)	—	100	—	120	mA
I <sub>CC2</sub> <sup>(3,5)</sup>	Standby Current ( $\overline{R}=\overline{W}=\overline{RS}=\overline{FL}/\overline{RT}=V_{IH}$ )	—	5	—	5	mA

NOTES:

- Measurements with 0.4 ≤ V<sub>IN</sub> ≤ V<sub>CC</sub>.
- $\overline{R} \geq V_{IH}$ , 0.4 ≤ V<sub>OUT</sub> ≤ V<sub>CC</sub>.
- Tested with outputs open (I<sub>OUT</sub> = 0).
- Tested at f = 20 MHz.
- All Inputs = V<sub>CC</sub> - 0.2V or GND + 0.2V.

## AC TEST CONDITIONS

Input Pulse Levels	GND to 3.0V
Input Rise/Fall Times	5ns
Input Timing Reference Levels	1.5V
Output Reference Levels	1.5V
Output Load	See Figure 1

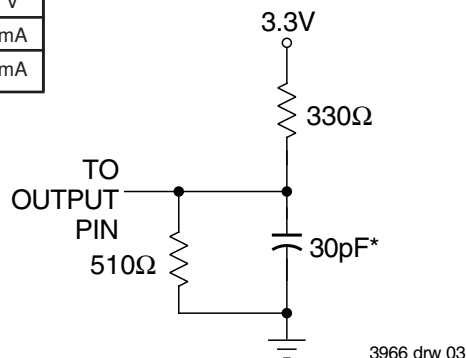

3966 drw 03

or equivalent circuit

Figure 1. Output Load

\*Includes scope and jib capacitances.

## AC ELECTRICAL CHARACTERISTICS<sup>(1)</sup>

(Commercial: V<sub>CC</sub> = 3.3V±0.3V, T<sub>A</sub> = 0°C to +70°C; Industrial: V<sub>CC</sub> = 3.3V±0.3V, T<sub>A</sub> = -40°C to +85°C)

Symbol	Parameter	Commercial		Commercial & Industrial		Unit
		Min.	Max.	Min.	Max.	
t <sub>s</sub>	Shift Frequency	—	40	—	33.3	MHz
t <sub>RC</sub>	Read Cycle Time	25	—	30	—	ns
t <sub>A</sub>	Access Time	—	15	—	20	ns
t <sub>RR</sub>	Read Recovery Time	10	—	10	—	ns
t <sub>RPW</sub>	Read Pulse Width <sup>(2)</sup>	15	—	20	—	ns
t <sub>RLZ</sub>	Read Pulse Low to Data Bus at Low Z <sup>(3)</sup>	3	—	3	—	ns
t <sub>WLZ</sub>	Write Pulse High to Data Bus at Low Z <sup>(3,4)</sup>	5	—	5	—	ns
t <sub>DV</sub>	Data Valid from Read Pulse High	5	—	5	—	ns
t <sub>RHZ</sub>	Read Pulse High to Data Bus at High Z <sup>(3)</sup>	—	15	—	15	ns
t <sub>WC</sub>	Write Cycle Time	25	—	30	—	ns
t <sub>WPW</sub>	Write Pulse Width <sup>(2)</sup>	15	—	20	—	ns
t <sub>WR</sub>	Write Recovery Time	10	—	10	—	ns
t <sub>DS</sub>	Data Set-up Time	11	—	12	—	ns
t <sub>DH</sub>	Data Hold Time	0	—	0	—	ns
t <sub>RSC</sub>	Reset Cycle Time	25	—	30	—	ns
t <sub>RS</sub>	Reset Pulse Width <sup>(2)</sup>	15	—	20	—	ns
t <sub>RSS</sub>	Reset Set-up Time <sup>(3)</sup>	15	—	20	—	ns
t <sub>RSR</sub>	Reset Recovery Time	10	—	10	—	ns
t <sub>RTC</sub>	Retransmit Cycle Time	25	—	30	—	ns
t <sub>RT</sub>	Retransmit Pulse Width <sup>(2)</sup>	15	—	20	—	ns
t <sub>RTS</sub>	Retransmit Set-up Time <sup>(3)</sup>	15	—	20	—	ns
t <sub>RTR</sub>	Retransmit Recovery Time	10	—	10	—	ns
t <sub>EFL</sub>	Reset to Empty Flag Low	—	25	—	30	ns
t <sub>HFFH</sub>	Reset to Half-Full and Full Flag High	—	25	—	30	ns
t <sub>RTF</sub>	Retransmit Low to Flags Valid	—	25	—	30	ns
t <sub>REF</sub>	Read Low to Empty Flag Low	—	15	—	20	ns
t <sub>RFF</sub>	Read High to Full Flag High	—	15	—	20	ns
t <sub>RPE</sub>	Read Pulse Width after $\overline{EF}$ High	15	—	20	—	ns
t <sub>WEF</sub>	Write High to Empty Flag High	—	15	—	20	ns
t <sub>WFF</sub>	Write Low to Full Flag Low	—	15	—	20	ns
t <sub>WHF</sub>	Write Low to Half-Full Flag Low	—	25	—	30	ns
t <sub>RHF</sub>	Read High to Half-Full Flag High	—	25	—	30	ns
t <sub>WPF</sub>	Write Pulse Width after $\overline{FF}$ High	15	—	20	—	ns
t <sub>XOL</sub>	Read/Write to $\overline{XO}$ Low	—	15	—	20	ns
t <sub>XOH</sub>	Read/Write to $\overline{XO}$ High	—	15	—	20	ns
t <sub>XI</sub>	$\overline{XI}$ Pulse Width <sup>(2)</sup>	15	—	20	—	ns
t <sub>XIR</sub>	$\overline{XI}$ Recovery Time	10	—	10	—	ns
t <sub>XIS</sub>	$\overline{XI}$ Set-up Time	10	—	10	—	ns

### NOTES:

1. Timings referenced as in AC Test Conditions.
2. Pulse widths less than minimum value are not allowed.
3. Values guaranteed by design, not currently tested.
4. Only applies to read data flow-through mode.

## SIGNAL DESCRIPTIONS

### INPUTS:

#### DATA IN (D<sub>0</sub> – D<sub>8</sub>)

Data inputs for 9-bit wide data.

### CONTROLS:

#### RESET ( $\overline{RS}$ )

Reset is accomplished whenever the Reset ( $\overline{RS}$ ) input is taken to a low state. During reset, both internal read and write pointers are set to the first location. A reset is required after power up before a write operation can take place. Both the Read Enable ( $\overline{R}$ ) and Write Enable ( $\overline{W}$ ) inputs must be in the high state during the window shown in Figure 2, (i.e.,  $t_{RSS}$  before the rising edge of  $\overline{RS}$ ) and should not change until  $t_{RSR}$  after the rising edge of  $\overline{RS}$ . Half-Full Flag ( $\overline{HF}$ ) will be reset to high after Reset ( $\overline{RS}$ ).

#### WRITE ENABLE ( $\overline{W}$ )

A write cycle is initiated on the falling edge of this input if the Full Flag ( $\overline{FF}$ ) is not set. Data set-up and hold times must be adhered to with respect to the rising edge of the Write Enable ( $\overline{W}$ ). Data is stored in the RAM array sequentially and independently of any on-going read operation.

After half of the memory is filled and at the falling edge of the next write operation, the Half-Full Flag ( $\overline{HF}$ ) will be set to low and will remain set until the difference between the write pointer and read pointer is less than or equal to one half of the total memory of the device. The Half-Full Flag ( $\overline{HF}$ ) is then reset by the rising edge of the read operation.

To prevent data overflow, the Full Flag ( $\overline{FF}$ ) will go low, inhibiting further write operations. Upon the completion of a valid read operation, the Full Flag ( $\overline{FF}$ ) will go high after  $t_{RFF}$ , allowing a valid write to begin. When the FIFO is full, the internal write pointer is blocked from  $\overline{W}$ , so external changes in  $\overline{W}$  will not affect the FIFO when it is full.

#### READ ENABLE ( $\overline{R}$ )

A read cycle is initiated on the falling edge of the Read Enable ( $\overline{R}$ ) provided the Empty Flag ( $\overline{EF}$ ) is not set. The data is accessed on a First-In/First-Out basis, independent of any ongoing write operations. After Read Enable ( $\overline{R}$ ) goes high, the Data Outputs (Q<sub>0</sub>–Q<sub>8</sub>) will return to a high impedance condition until the next Read operation. When all data has been read from the FIFO, the Empty Flag ( $\overline{EF}$ ) will go low, allowing the “final” read cycle but inhibiting further read operations with the data outputs remaining in a high impedance state. Once a valid write operation has been accomplished, the Empty Flag ( $\overline{EF}$ ) will go high after  $t_{WEF}$  and a valid Read can then begin. When the FIFO is empty, the internal read pointer is blocked from  $\overline{R}$  so external changes in  $\overline{R}$  will not affect the FIFO when it is empty.

#### FIRST LOAD/RETRANSMIT ( $\overline{FL/RT}$ )

This is a dual-purpose input. In the Depth Expansion Mode, this pin is grounded to indicate that it is the first loaded (see Operating Modes). In the

Single Device Mode, this pin acts as the retransmit input. The Single Device Mode is initiated by grounding the Expansion In ( $\overline{XI}$ ).

The IDT72V81/72V82/72V83/72V84/72V85 can be made to retransmit data when the Retransmit Enable control ( $\overline{RT}$ ) input is pulsed low. A retransmit operation will set the internal read pointer to the first location and will not affect the write pointer. Read Enable ( $\overline{R}$ ) and Write Enable ( $\overline{W}$ ) must be in the high state during retransmit for the IDT72V81/72V82/72V83/72V84/72V85 respectively. This feature is useful when less than 512/1,024/2,048/4,096/8,192 writes are performed between resets. The retransmit feature is not compatible with the Depth Expansion Mode and will affect the Half-Full Flag ( $\overline{HF}$ ), depending on the relative locations of the read and write pointers.

#### EXPANSION IN ( $\overline{XI}$ )

This input is a dual-purpose pin. Expansion In ( $\overline{XI}$ ) is grounded to indicate an operation in the single device mode. Expansion In ( $\overline{XI}$ ) is connected to Expansion Out ( $\overline{XO}$ ) of the previous device in the Depth Expansion or Daisy Chain Mode.

### OUTPUTS:

#### FULL FLAG ( $\overline{FF}$ )

The Full Flag ( $\overline{FF}$ ) will go low, inhibiting further write operation, when the write pointer is one location less than the read pointer, indicating that the device is full. If the read pointer is not moved after Reset ( $\overline{RS}$ ), the Full-Flag ( $\overline{FF}$ ) will go low after 512 writes for the IDT72V81, 1,024 writes for the IDT72V82, 2,048 writes for the IDT72V83, 4,096 writes for the IDT72V84 and 8,192 writes for the IDT72V85.

#### EMPTY FLAG ( $\overline{EF}$ )

The Empty Flag ( $\overline{EF}$ ) will go low, inhibiting further read operations, when the read pointer is equal to the write pointer, indicating that the device is empty.

#### EXPANSION OUT/HALF-FULL FLAG ( $\overline{XO/HF}$ )

This is a dual-purpose output. In the single device mode, when Expansion In ( $\overline{XI}$ ) is grounded, this output acts as an indication of a half-full memory.

After half of the memory is filled and at the falling edge of the next write operation, the Half-Full Flag ( $\overline{HF}$ ) will be set low and will remain set until the difference between the write pointer and read pointer is less than or equal to one half of the total memory of the device. The Half-Full Flag ( $\overline{HF}$ ) is then reset by using rising edge of the read operation.

In the Depth Expansion Mode, Expansion In ( $\overline{XI}$ ) is connected to Expansion Out ( $\overline{XO}$ ) of the previous device in the Daisy Chain by providing a pulse to the next device when the previous device reaches the last location of memory.

#### DATA OUTPUTS (Q<sub>0</sub>–Q<sub>8</sub>)

Data outputs for 9-bit wide data. This data is in a high impedance condition whenever Read ( $\overline{R}$ ) is in a high state.

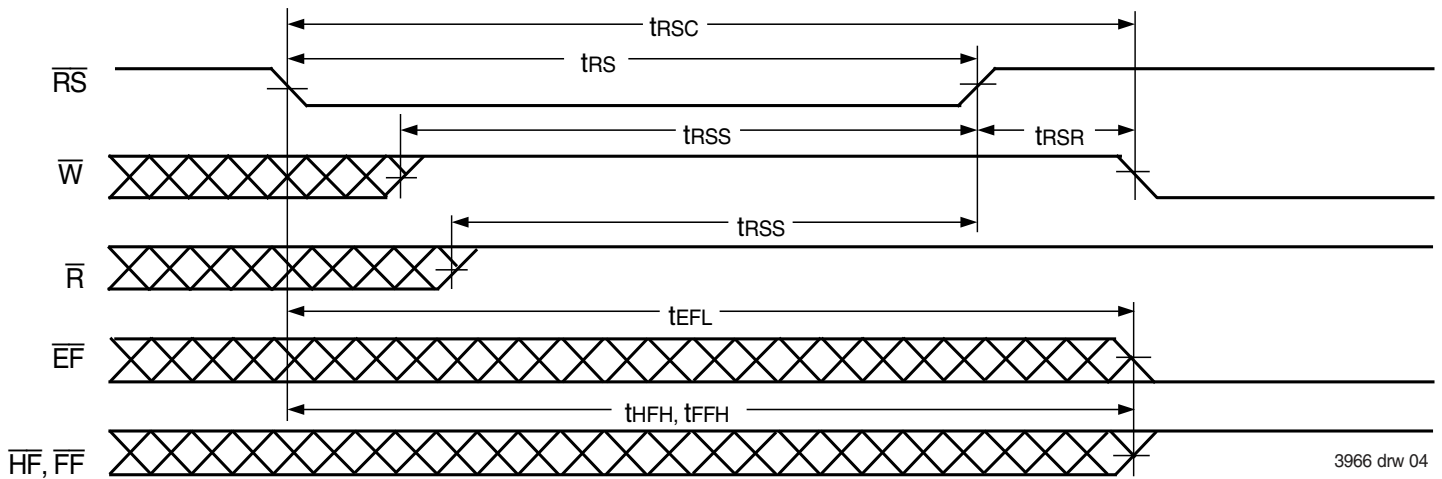

- NOTES:
- $\overline{EF}$ ,  $\overline{FF}$ ,  $\overline{HF}$  may change status during Reset, but flags will be valid at  $t_{RSC}$ .
  - $\overline{W}$  and  $\overline{R}$  =  $V_{IH}$  around the rising edge of  $\overline{RS}$ .

Figure 2. Reset

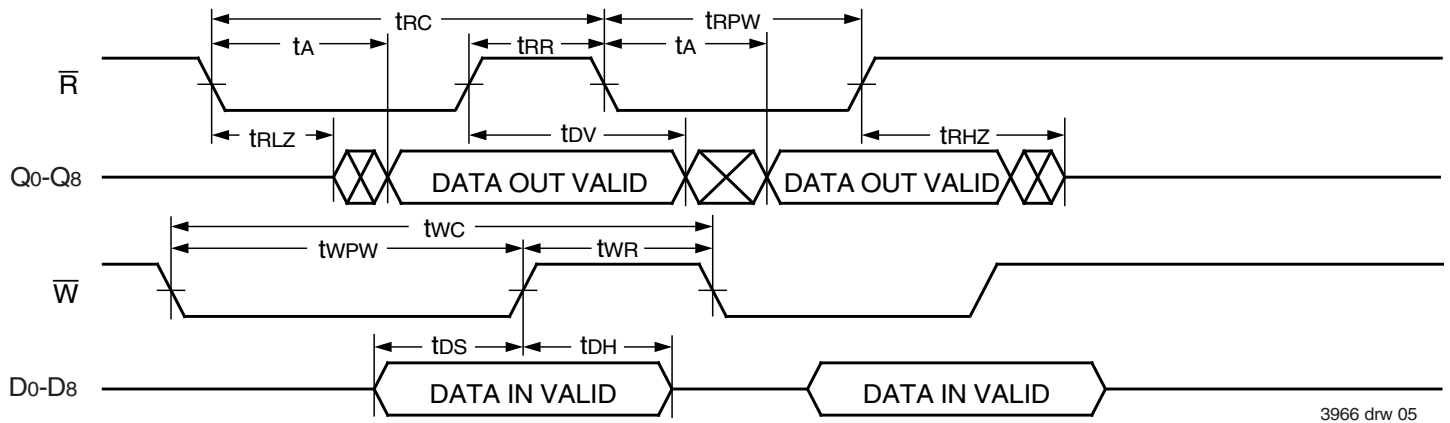

Figure 3. Asynchronous Write and Read Operation

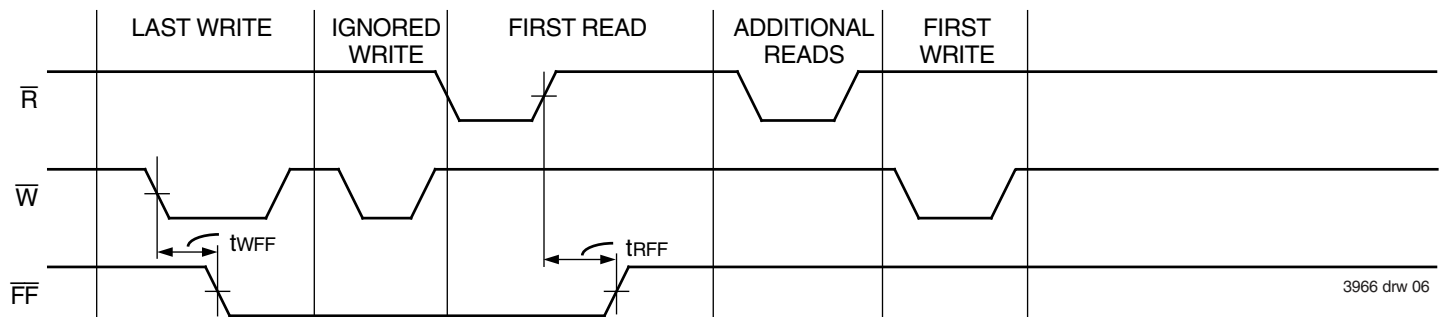

Figure 4. Full Flag From Last Write to First Read

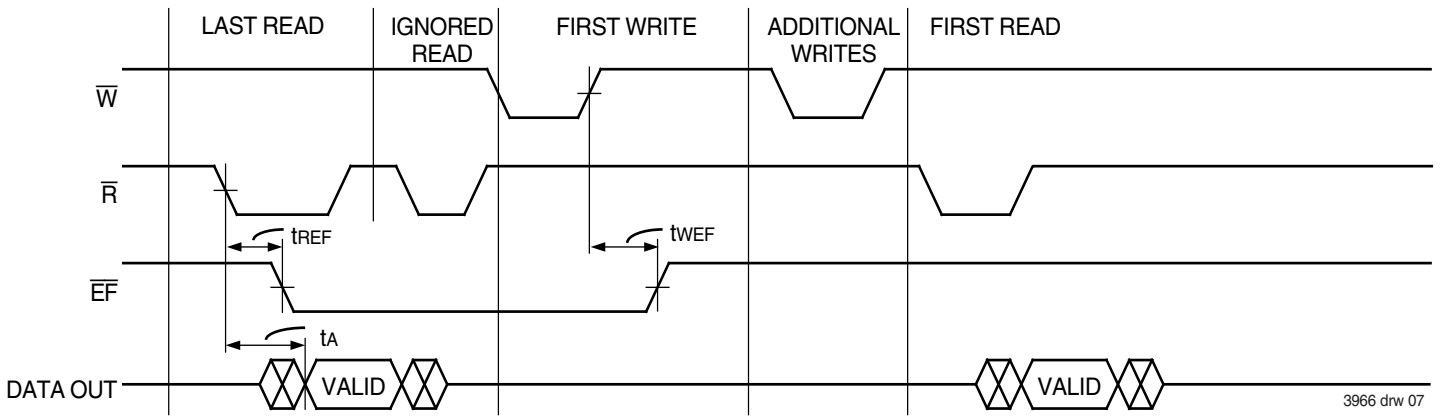

Figure 5. Empty Flag From Last Read to First Write

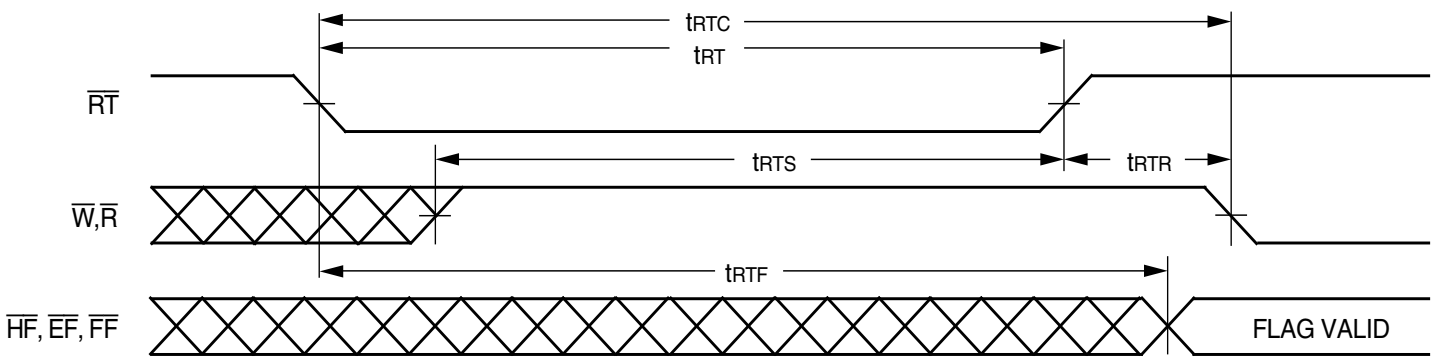

Figure 6. Retransmit



Figure 7. Minimum Timing for an Empty Flag Coincident Read Pulse

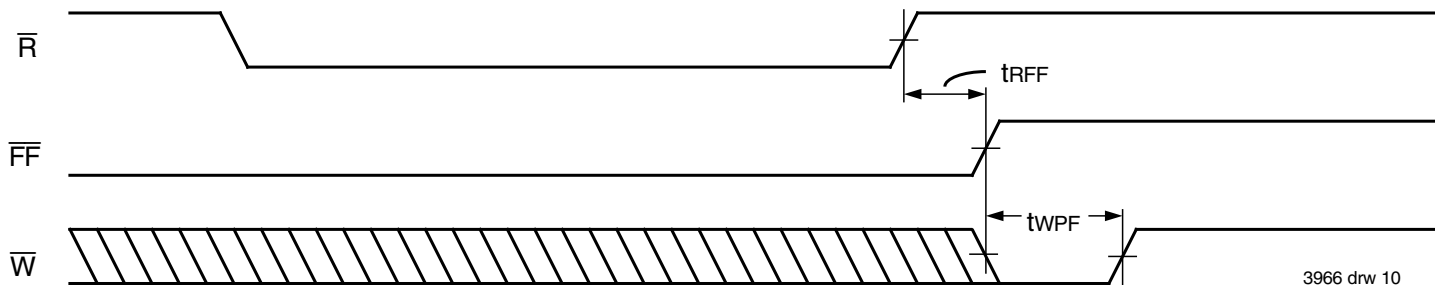

Figure 8. Minimum Timing for a Full Flag Coincident Write Pulse

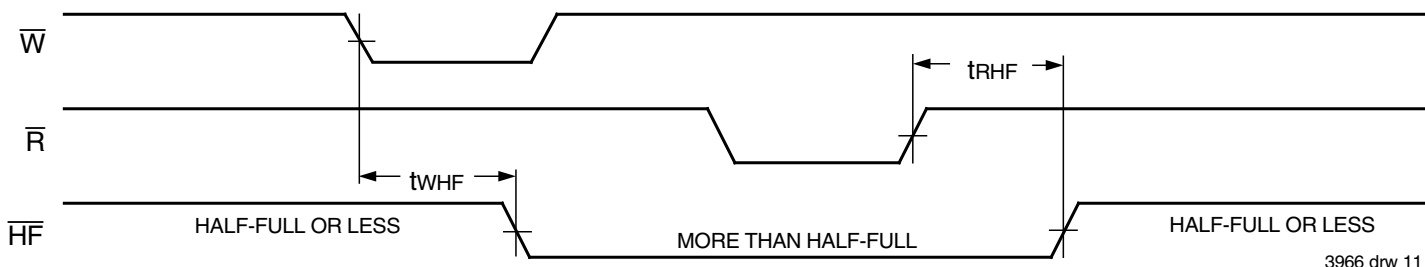

Figure 9. Half-Full Flag Timing

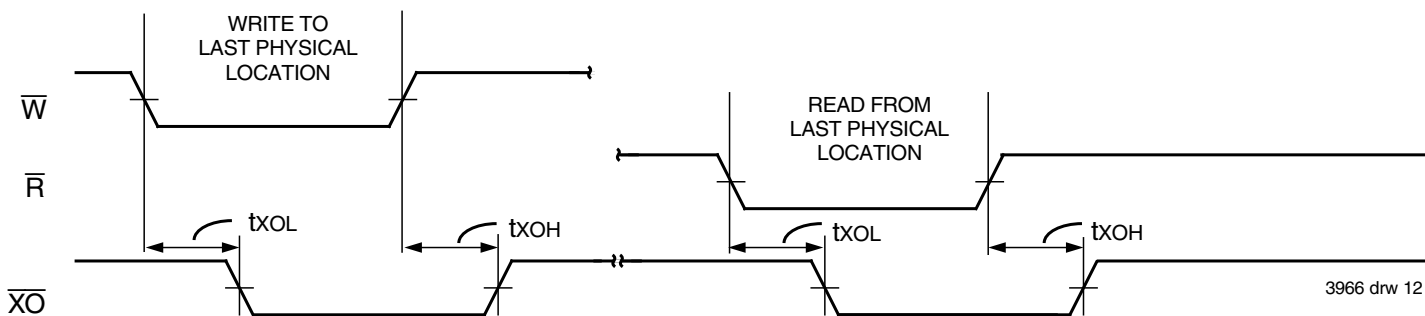

Figure 10. Expansion Out

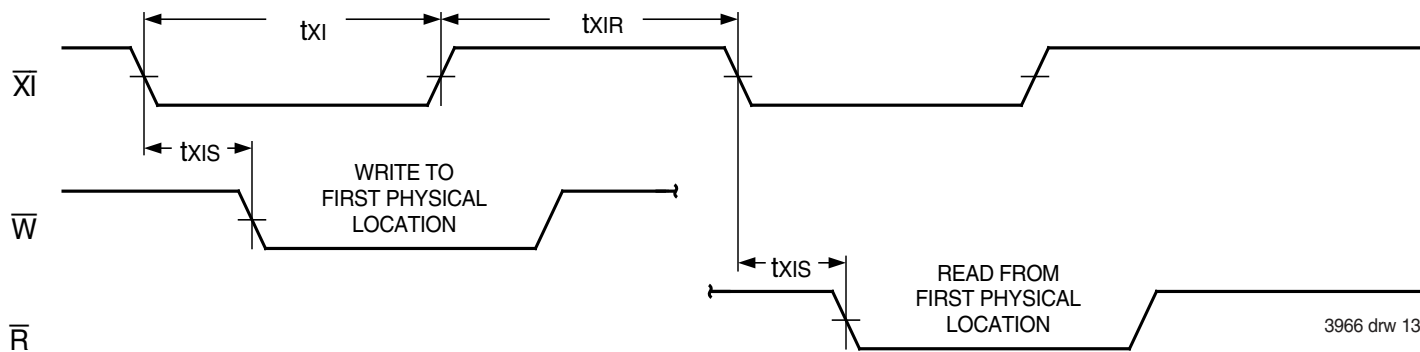

Figure 11. Expansion In

## OPERATING MODES:

Care must be taken to assure that the appropriate flag is monitored by each system (i.e.  $\overline{FF}$  is monitored on the device where  $\bar{W}$  is used;  $\overline{EF}$  is monitored on the device where  $\bar{R}$  is used).

### Single Device Mode

A single IDT72V81/72V82/72V83/72V84/72V85 may be used when the application requirements are for 512/1,024/2,048/4,096/8,192 words or less. These FIFOs are in a Single Device Configuration when the Expansion In ( $\overline{XI}$ ) control input is grounded (see Figure 12).

### Depth Expansion

These devices can easily be adapted to applications when the requirements are for greater than 512/1,024/2,048/4,096/8,192 words. Figure 14 demon-

strates a four-FIFO Depth Expansion using two IDT72V81/72V82/72V83/72V84/72V85s. Any depth can be attained by adding additional IDT72V81/72V82/72V83/72V84/72V85s. These FIFOs operate in the Depth Expansion mode when the following conditions are met:

1. The first FIFO must be designated by grounding the First Load ( $\overline{FL}$ ) control input.
2. All other FIFOs must have  $\overline{FL}$  in the high state.
3. The Expansion Out ( $\overline{XO}$ ) pin of each device must be tied to the Expansion In ( $\overline{XI}$ ) pin of the next device. See Figure 14.
4. External logic is needed to generate a composite Full Flag ( $\overline{FF}$ ) and Empty Flag ( $\overline{EF}$ ). This requires the ORing of all  $\overline{EF}$ s and ORing of all  $\overline{FF}$ s (i.e. all must be set to generate the correct composite  $\overline{FF}$  or  $\overline{EF}$ ). See Figure 14.
5. The Retransmit ( $\overline{RT}$ ) function and Half-Full Flag ( $\overline{HF}$ ) are not available in the Depth Expansion Mode.

## USAGE MODES:

### Width Expansion

Word width may be increased simply by connecting the corresponding input control signals of multiple FIFOs. Status flags ( $\overline{EF}$ ,  $\overline{FF}$  and  $\overline{HF}$ ) can be detected from any one FIFO. Figure 13 demonstrates an 18-bit word width by using the two FIFOs contained in the IDT72V81/72V82/72V83/72V84/72V85s. Any word width can be attained by adding FIFOs (Figure 13).

### Bidirectional Operation

Applications which require data buffering between two systems (each system capable of Read and Write operations) can be achieved by pairing IDT72V81/72V82/72V83/72V84/72V85s as shown in Figure 16. Both Depth Expansion and Width Expansion may be used in this mode.

### Data Flow-Through

Two types of flow-through modes are permitted, a read flow-through and write flow-through mode. For the read flow-through mode (Figure 17), the

FIFO permits a reading of a single word after writing one word of data into an empty FIFO. The data is enabled on the bus in ( $t_{WEF} + t_A$ ) ns after the rising edge of  $\overline{W}$ , called the first write edge, and it remains on the bus until the  $\overline{R}$  line is raised from low-to-high, after which the bus would go into a three-state mode after  $t_{RHZ}$  ns. The  $\overline{EF}$  line would have a pulse showing temporary deassertion and then would be asserted.

In the write flow-through mode (Figure 18), the FIFO permits the writing of a single word of data immediately after reading one word of data from a full FIFO. The  $\overline{R}$  line causes the  $\overline{FF}$  to be deasserted but the  $\overline{W}$  line being low causes it to be asserted again in anticipation of a new data word. On the rising edge of  $\overline{W}$ , the new word is loaded in the FIFO. The  $\overline{W}$  line must be toggled when  $\overline{FF}$  is not asserted to write new data in the FIFO and to increment the write pointer.

### Compound Expansion

The two expansion techniques described above can be applied together in a straightforward manner to achieve large FIFO arrays (see Figure 15).

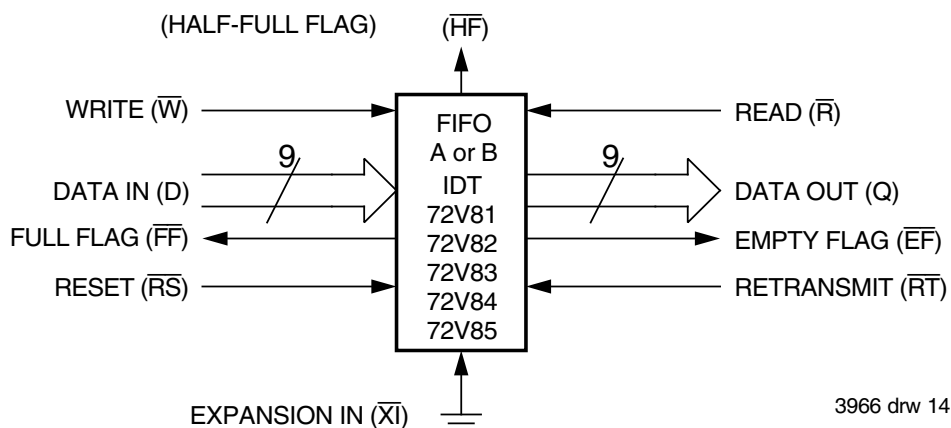

3966 drw 14

Figure 12. Block Diagram of One 512 x 9, 1,024 x 9, 2,048 x 9, 4,096 x 9 and 8,192 x 9 FIFO Used in Single Device Mode

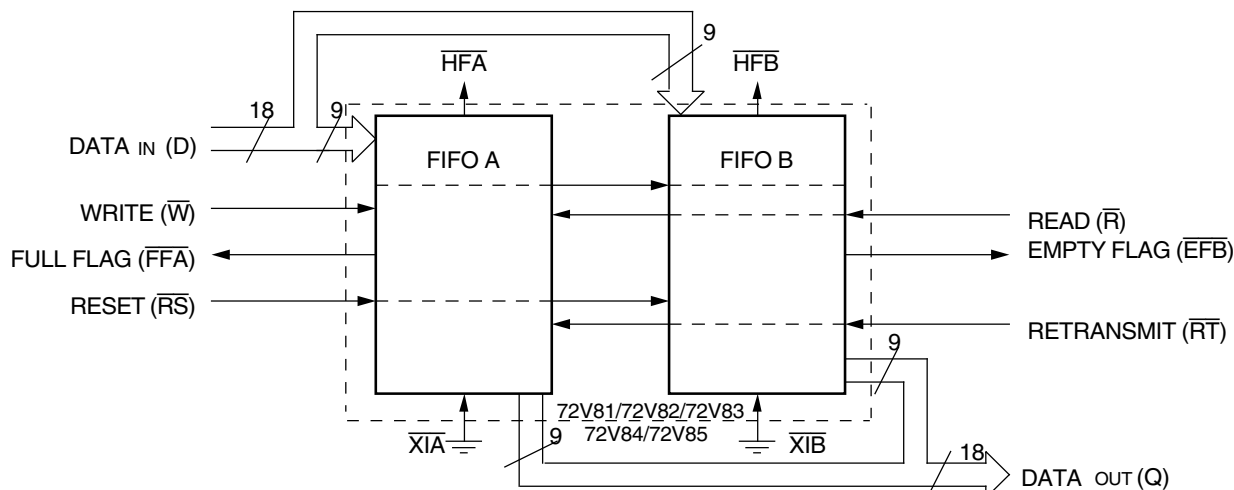

3966 drw 15

Figure 13. Block Diagram of One 512 x 18, 1,024 x 18, 2,048 x 18, 4,096 x 18 and 8,192 x 18 FIFO Memory Used in Width Expansion Mode



### TABLE I—RESET AND RETRANSMIT

Single Device Configuration/Width Expansion Mode

Mode	Inputs			Internal Status		Outputs		
	$\overline{RS}$	$\overline{RT}$	$\overline{XI}$	Read Pointer	Write Pointer	$\overline{EF}$	$\overline{FF}$	$\overline{HF}$
Reset	0	X	0	Location Zero	Location Zero	0	1	1
Retransmit	1	0	0	Location Zero	Unchanged	X	X	X
Read/Write	1	1	0	Increment <sup>(1)</sup>	Increment <sup>(1)</sup>	X	X	X

NOTE:

1. Pointer will increment if flag is High.

### TABLE II—RESET AND FIRST LOAD TRUTH TABLE

Depth Expansion/Compound Expansion Mode

Mode	Inputs			Internal Status		Outputs	
	$\overline{RS}$	$\overline{FL}$	$\overline{XI}$	Read Pointer	Write Pointer	$\overline{EF}$	$\overline{FF}$
Reset First Device	0	0	(1)	Location Zero	Location Zero	0	1
Reset All Other Devices	0	1	(1)	Location Zero	Location Zero	0	1
Read/Write	1	X	(1)	X	X	X	X

NOTE:

1.  $\overline{XI}$  is connected to  $\overline{XO}$  of previous device. See Figure 14.  $\overline{RS}$  = Reset Input,  $\overline{FL}/\overline{RT}$  = First Load/Retransmit,  $\overline{EF}$  = Empty Flag Output,  $\overline{FF}$  = Full Flag Output,  $\overline{XI}$  = Expansion Input,  $\overline{HF}$  = Half-Full Flag Output

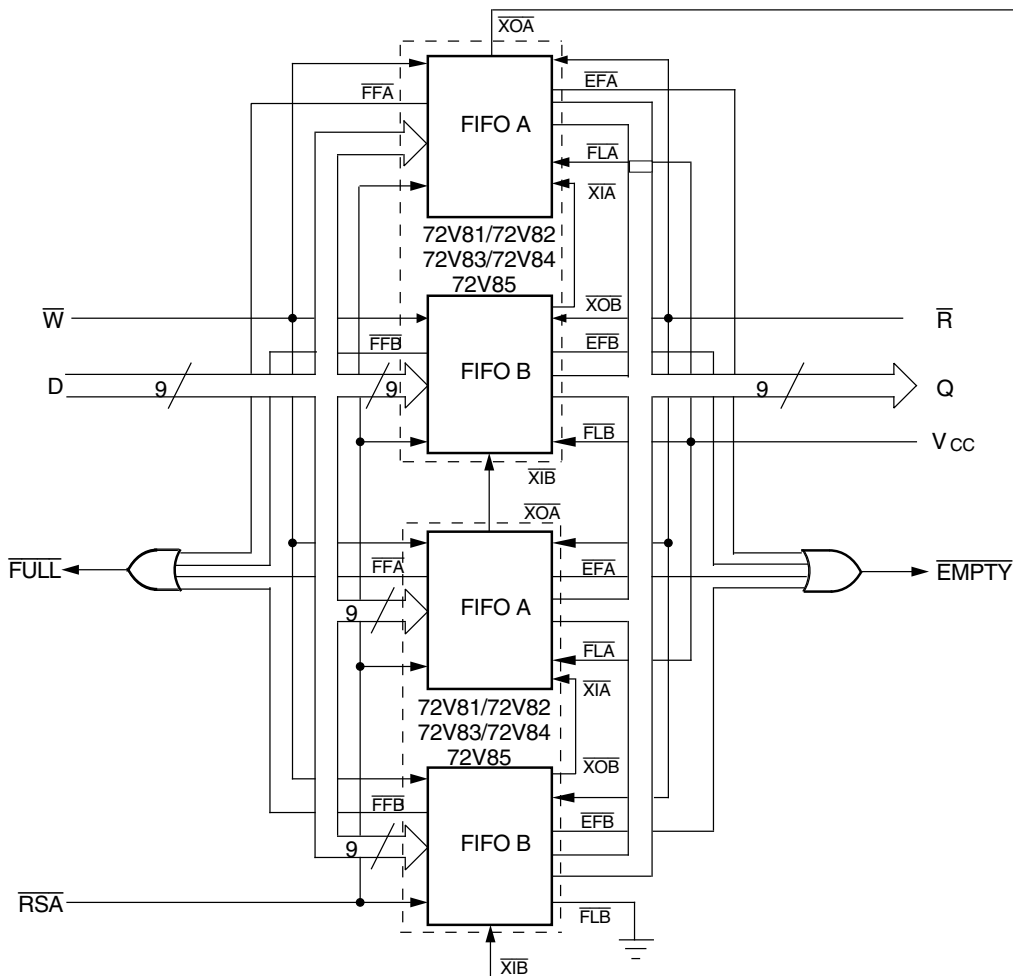

3966 drw 16

Figure 14. Block Diagram of 2,048 x 9, 4,096 x 9, 8,192 x 9, 16,384 x 9 and 32,768 x 9 FIFO Memory (Depth Expansion)

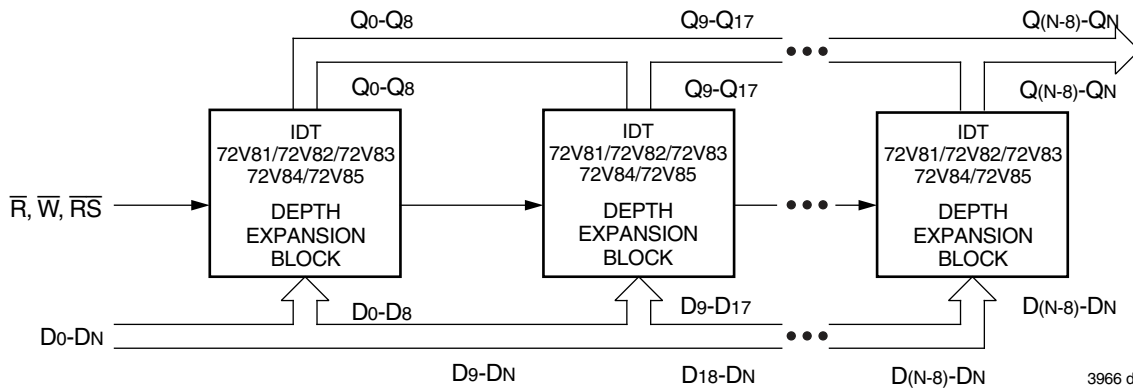

NOTES:

1. For depth expansion block see section on Depth Expansion and Figure 14.
2. For Flag detection see section on Width Expansion and Figure 13.

Figure 15. Compound FIFO Expansion

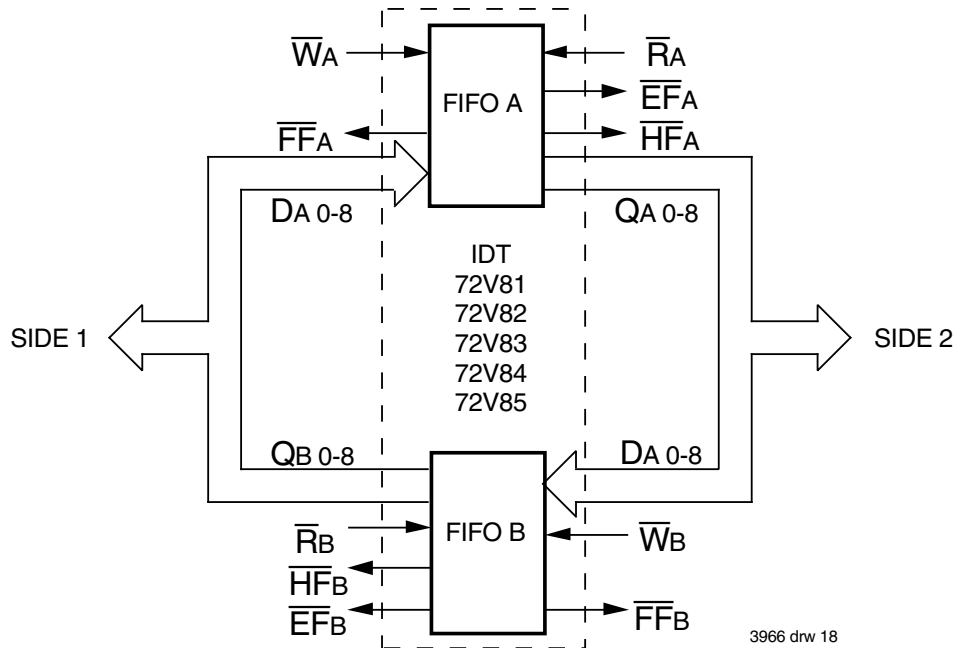

Figure 16. Bidirectional FIFO Mode

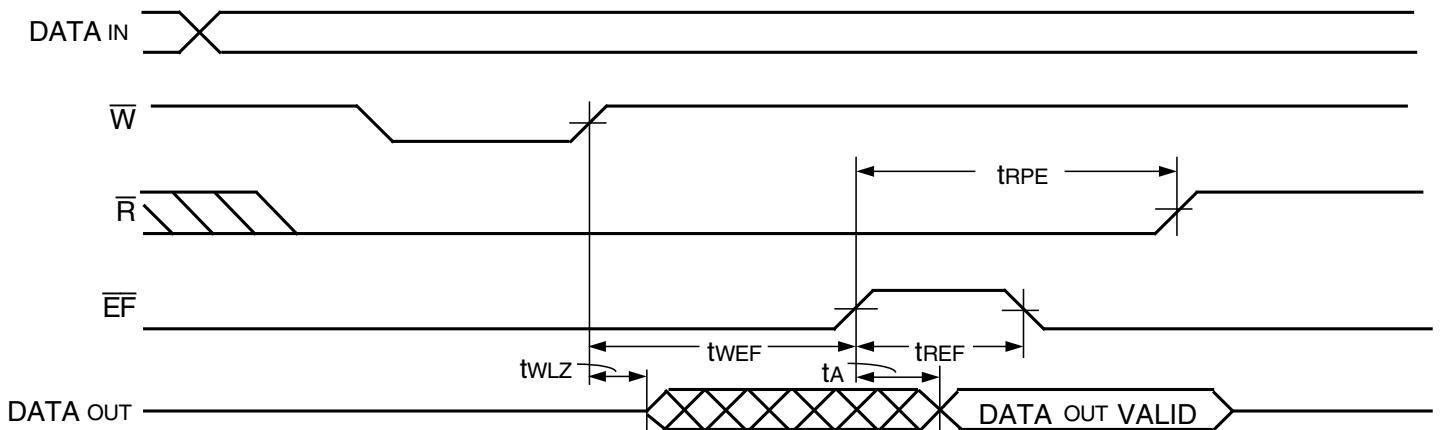

Figure 17. Read Data Flow-Through Mode

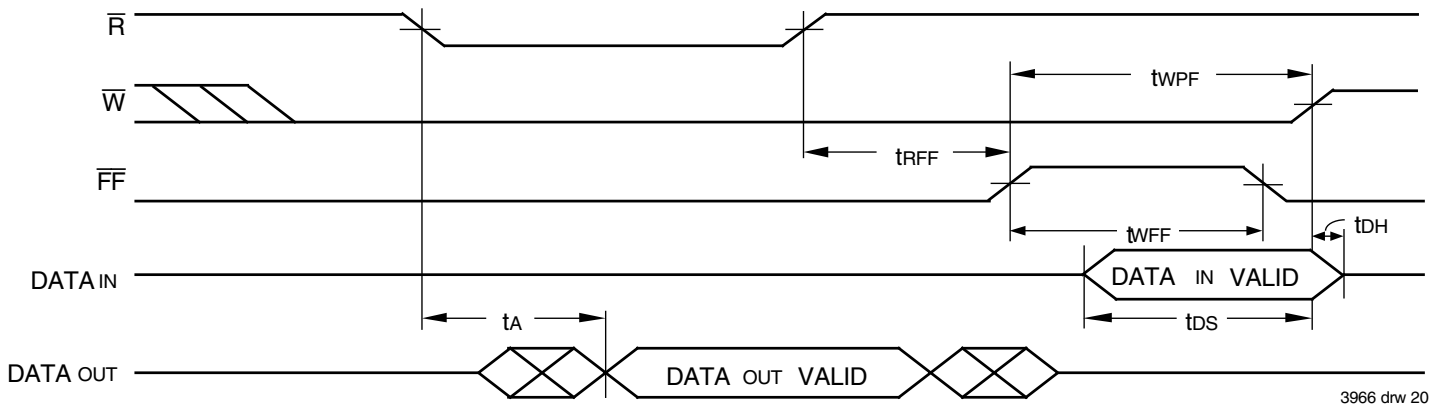
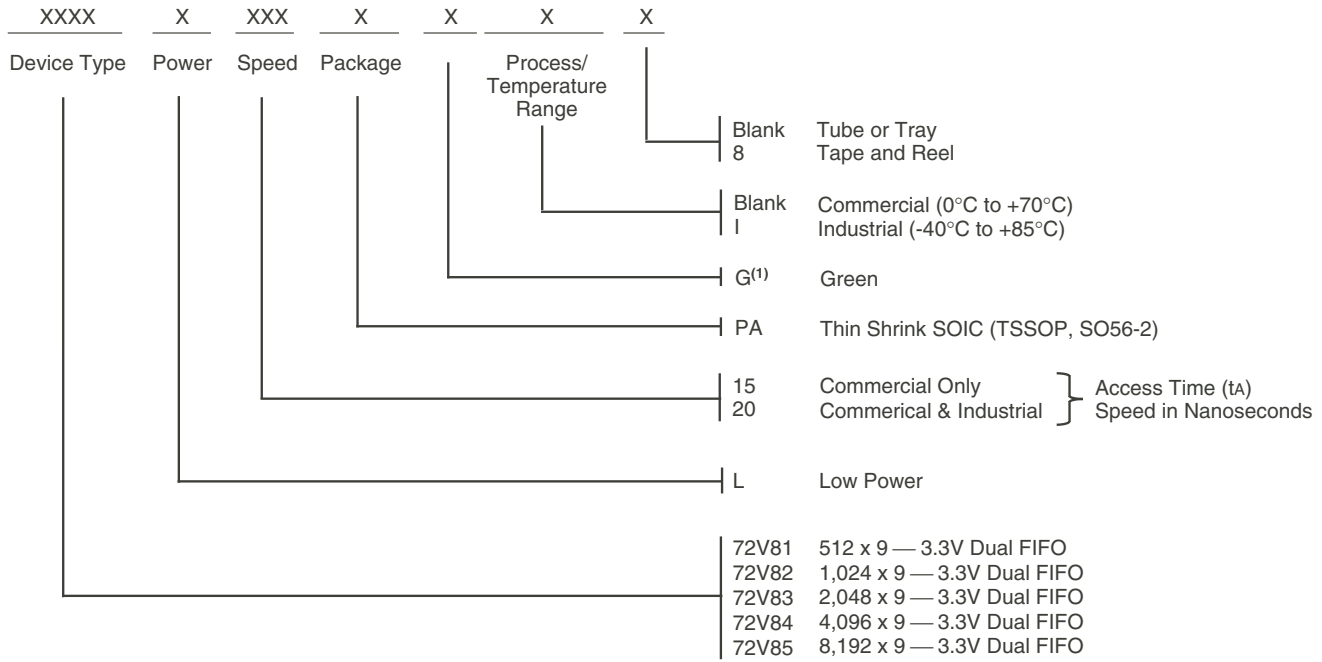

Figure 18. Write Data Flow-Through Mode

3966 drw 20

# ORDERING INFORMATION



3966 drw 21

**NOTE:**

- 1. Green parts are available. For specific speeds contact your local sales office.  
**LEAD FINISH (SnPb) parts are in EOL process. Product Discontinuation Notice - PDN# SP-17-02**

## IMPORTANT NOTICE AND DISCLAIMER

RENESAS ELECTRONICS CORPORATION AND ITS SUBSIDIARIES (“RENESAS”) PROVIDES TECHNICAL SPECIFICATIONS AND RELIABILITY DATA (INCLUDING DATASHEETS), DESIGN RESOURCES (INCLUDING REFERENCE DESIGNS), APPLICATION OR OTHER DESIGN ADVICE, WEB TOOLS, SAFETY INFORMATION, AND OTHER RESOURCES “AS IS” AND WITH ALL FAULTS, AND DISCLAIMS ALL WARRANTIES, EXPRESS OR IMPLIED, INCLUDING, WITHOUT LIMITATION, ANY IMPLIED WARRANTIES OF MERCHANTABILITY, FITNESS FOR A PARTICULAR PURPOSE, OR NON-INFRINGEMENT OF THIRD PARTY INTELLECTUAL PROPERTY RIGHTS.

These resources are intended for developers skilled in the art designing with Renesas products. You are solely responsible for (1) selecting the appropriate products for your application, (2) designing, validating, and testing your application, and (3) ensuring your application meets applicable standards, and any other safety, security, or other requirements. These resources are subject to change without notice. Renesas grants you permission to use these resources only for development of an application that uses Renesas products. Other reproduction or use of these resources is strictly prohibited. No license is granted to any other Renesas intellectual property or to any third party intellectual property. Renesas disclaims responsibility for, and you will fully indemnify Renesas and its representatives against, any claims, damages, costs, losses, or liabilities arising out of your use of these resources. Renesas' products are provided only subject to Renesas' Terms and Conditions of Sale or other applicable terms agreed to in writing. No use of any Renesas resources expands or otherwise alters any applicable warranties or warranty disclaimers for these products.

(Disclaimer Rev.1.0 Mar 2020)

### Corporate Headquarters

TOYOSU FORESIA, 3-2-24 Toyosu,  
Koto-ku, Tokyo 135-0061, Japan  
[www.renesas.com](http://www.renesas.com)

### Contact Information

For further information on a product, technology, the most up-to-date version of a document, or your nearest sales office, please visit:  
[www.renesas.com/contact/](http://www.renesas.com/contact/)

### Trademarks

Renesas and the Renesas logo are trademarks of Renesas Electronics Corporation. All trademarks and registered trademarks are the property of their respective owners.