

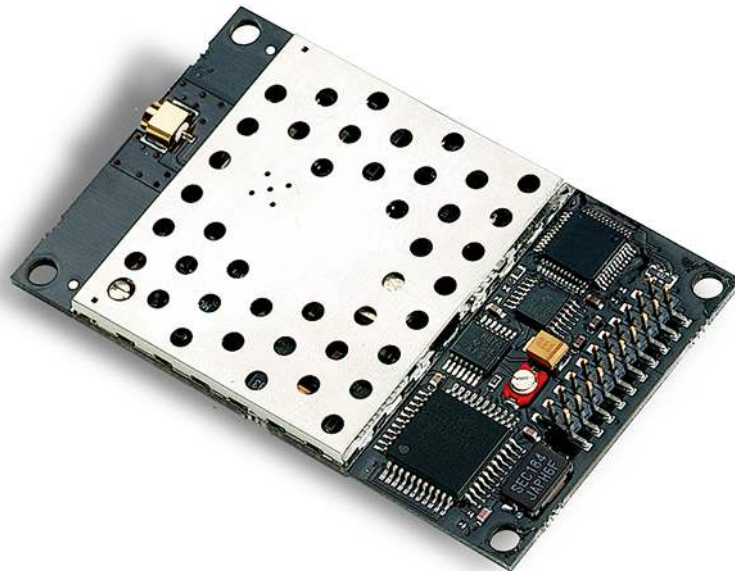

AC4424
2.4 GHz OEM TRANSCEIVERS

Specifications Subject to Change

User's Manual
Version 2.0



11160 THOMPSON AVENUE
LENEXA, KS 66219
(800) 492-2320
www.aerocomm.com
wireless@aerocomm.com

DOCUMENT INFORMATION

Copyright Information

Copyright © 2005 AEROCOMM, Inc. All rights reserved. The information contained in this manual and the accompanying software programs are copyrighted and all rights are reserved by AEROCOMM, Inc. AEROCOMM, Inc. reserves the right to make periodic modifications of this product without obligation to notify any person or entity of such revision. Copying, duplicating, selling, or otherwise distributing any part of this product without the prior consent of an authorized representative of AEROCOMM, Inc. is prohibited.

All brands and product names in this publication are registered trademarks or trademarks of their respective holders.

This material is preliminary

Information furnished by AEROCOMM in this specification is believed to be accurate. Devices sold by AEROCOMM are covered by the warranty and patent indemnification provisions appearing in its Terms of Sale only. AEROCOMM makes no warranty, express, statutory, and implied or by description, regarding the information set forth herein. AEROCOMM reserves the right to change specifications at any time and without notice.

AEROCOMM's products are intended for use in normal commercial and industrial applications. Applications requiring unusual environmental requirements such as military, medical life-support or life-sustaining equipment are specifically not recommended without additional testing for such application.

Limited Warranty, Disclaimer, Limitation of Liability

For a period of one (1) year from the date of purchase by the OEM customer, AeroComm warrants the OEM transceiver against defects in materials and workmanship. AeroComm will not honor this warranty (and this warranty will be automatically void) if there has been any (1) tampering, signs of tampering; 2) repair or attempt to repair by anyone other than an AeroComm authorized technician.

This warranty does not cover and AeroComm will not be liable for, any damage or failure caused by misuse, abuse, acts of God, accidents, electrical irregularity, or other causes beyond AeroComm's control, or claim by other than the original purchaser.

In no event shall AeroComm be responsible or liable for any damages arising: From the use of product; From the loss of use, revenue or profit of the product; or As a result of any event, circumstance, action, or abuse beyond the control of AeroComm, whether such damages be direct, indirect, consequential, special or otherwise and whether such damages are incurred by the person to whom this warranty extends or third party.

If, after inspection, AeroComm determines that there is a defect, AeroComm will repair or replace the OEM transceiver at their discretion. If the product is replaced, it may be a new or refurbished product.

DOCUMENT INFORMATION

<u>Revision</u>	<u>Description</u>
Version 1.0	11/7/2001 – Initial Release Version
Version 1.1	10/14/2002 – Not Released
Version 1.2	10/18/2002 – Full release of AC4424 specification
Version 1.3	11/19/2002 – Made Full-Duplex incompatible with Stream Mode
Version 1.4	12/09/2002 – Changed Sub Hop Adjust setting recommendations
Version 1.5	1/30/2003 – Removed all references to Commercial and Industrial temperature. All products are now Industrial temperature. Changed Section 4.2.1 EEPROM Byte Read to allow multiple byte reads.
Version 1.6	4/30/2004 – Added warranty information. Updated agency compliancy. Added new RSSI plot. Updated Channel Number information. Added configuration flow chart and timing diagrams. Updated approved antenna table. Added AC4424-10A information.
Version 1.7	5/5/2004 – Modified references from Table 9 to Table 11.
Version 1.8	5/10/2004 – Changed start-up time to reflect addition of microprocessor supervisor. Updated Auto Config table.
Version 1.9	5/10/2005 - Added the following CC Commands; Sync Channel, EEPROM Byte Read/Write and Soft Reset. Added AT Commands. Removed Configuration command documentation (though the firmware will continue to support their usage). Added Auto Destination and Random Backoff.
Version 2.0	3/23/2006 - Removed Stream mode, FEC and Frequency Offset documentation. Corrected Random backoff byte.

TABLE OF CONTENTS

1.	OVERVIEW	6
2.	AC4424 SPECIFICATIONS	7
3.	SPECIFICATIONS	8
3.1	INTERFACE SIGNAL DEFINITIONS	8
3.2	ELECTRICAL SPECIFICATIONS.....	9
3.3	SYSTEM TIMING	9
3.3.1	Serial Interface Data Rate.....	9
3.3.2	Timing Diagrams.....	10
3.3.3	Maximum Overall System Throughput	12
4.	CONFIGURING THE AC4424.....	13
4.1	EEPROM PARAMETERS.....	13
4.2	CONFIGURING THE AC4424	15
4.3	COMMAND REFERENCE.....	16
4.4	AC4424 AT COMMANDS	17
4.4.1	Enter AT Command Mode.....	17
4.4.2	Exit AT Command Mode.....	17
4.5	ON-THE-FLY CONTROL COMMANDS (CC COMMAND MODE)	18
4.5.1	Status Request.....	18
4.5.2	Change Channel with Forced Acquisition Sync	19
4.5.3	Server/Client.....	19
4.5.4	Sync Channel.....	19
4.5.5	Power-Down.....	20
4.5.6	Power-Down Wake-Up.....	20
4.5.7	Broadcast Mode.....	20
4.5.8	Write Destination Address.....	21
4.5.9	Read Destination Address.....	21
4.5.10	EEPROM Byte Read.....	21
4.5.11	EEPROM Byte Write	22
4.5.12	Reset	22
5.	THEORY OF OPERATION	23
5.1	HARDWARE INTERFACE.....	23
5.1.1	TXD (Transmit Data) and RXD (Receive Data) (pins 2 and 3 respectively).....	23
5.1.2	Hop Frame (pin 6).....	23
5.1.3	CTS Handshaking (pin 7).....	23
5.1.4	RTS Handshaking (pin 8).....	23
5.1.5	9600 Baud/Packet Frame (pin 12).....	24
5.1.6	RSSI (pin 13).....	24
5.1.7	Wr_ENA(EEPROM Write Enable) (pin 14)	25
5.1.8	UP_RESET (pin 15).....	26
5.1.9	Command/Data (pin 17).....	26
5.1.10	In Range (pin 20).....	26
5.2	SOFTWARE PARAMETERS	27
5.2.1	RF Architecture (Server-Client/Peer-to-Peer)	27
5.2.2	RF Mode	27
5.2.3	Random Back Off.....	28
5.2.4	Sub Hop Adjust	28
5.2.5	Duplex Mode	29
5.2.6	Interface Timeout/RF Packet Size.....	29

5.2.7	Serial Interface Baud Rate.....	30
5.2.8	Network Topology.....	30
5.2.9	Auto Config.....	32
6.	DIMENSIONS	33
7.	ORDERING INFORMATION.....	35
7.1	PRODUCT PART NUMBERS.....	35
7.2	DEVELOPER KIT PART NUMBERS	35
8.	REGULATORY INFORMATION.....	36
8.1	FCC	36
8.2	CE.....	38
8.3	APPROVED ANTENNA LIST.....	39

Figures

Figure 1 - RSSI Voltage vs. Received Signal Strength	25
Figure 2 – AC4424 with MMCX	33
Figure 3 – AC4424 with Integral Antenna	34

Tables

Table 1 – Pin Definitions.....	8
Table 2 – DC Input Voltage Characteristics.....	9
Table 3 – DC Output Voltage Characteristics	9
Table 4 – Timing Parameters.....	12
Table 5 – Maximum Overall System Throughputs	12
Table 6 – EEPROM Parameters	13
Table 7 – RSSI Board Rev History	25
Table 8 – Sub Hop Adjust Settings	28
Table 9 – Baud Rate	30
Table 10 – US and International RF Channel Number Settings.....	31
Table 11 – Auto Config Parameters	32

AC4424 Features

- ✓ Simple 5V TTL level serial interface for fast integration
- ✓ Frequency Hopping Spread Spectrum for security and interference rejection
- ✓ Cost Efficient for high volume applications
- ✓ Low power consumption for battery powered implementations
- ✓ Small size for portable and enclosed applications
- ✓ Very Low latency and high throughput
- ✓ Industrial temperature (-40°C to 80°C)

1. Overview

The AC4424 is a member of AeroComm's ConnexRF OEM transceiver family. It is designed for integration into OEM systems operating under FCC part 15.247 regulations for the 2.4 GHz ISM band.

The AC4424 is a cost-effective, High performance, 2.4 GHz frequency hopping spread spectrum transceiver. It provides an asynchronous TTL level serial interface for OEM Host communications. Communications include both system and configuration data. The Host supplies system data for transmission to other Host(s). Configuration data is stored in an on-board EEPROM. All frequency hopping, synchronization, and RF system data transmission/reception is performed by the transceiver.

The AC4424 transceivers can be used as a direct serial cable replacement – requiring no special Host software for operation. They also feature a number of On-the-Fly Control Commands providing the OEM Host with a very versatile interface for any situation.

AC4424 transceivers operate in a Point-to-Point or Point-to-Multipoint, Client-Server or Peer-to-Peer architecture. One transceiver is configured as a Server and there can be one or many Clients. To establish synchronization between transceivers, the Server emits a beacon. Upon detecting a beacon, a Client transceiver informs its Host and a RF link is established.

There are two data rates the OEM should be aware of:

- Serial Interface Data Rate – All transceivers can be configured to common PC serial port baud rates from 110 bps to 288,000 bps.
- Effective Data Transmission Rate – The AC4424 is a highly efficient, low-latency transceiver.

This document contains information about the hardware and software interface between an AeroComm AC4424 transceiver and an OEM Host. Information includes the theory of operation, specifications, interface definition, configuration information and mechanical drawing.

The OEM is responsible for ensuring the final product meets all FCC and/or appropriate regulatory agency requirements listed herein before selling any product.

2. AC4424 Specifications

GENERAL																									
Interface	20 pin mini-connector																								
Serial Interface Data Rate	PC baud rates from 110 bps to 288,000 bps																								
Power Consumption (typical)	<p style="text-align: center;">Duty Cycle (TX=Transmit; RX=Receive)</p> <table border="1" style="width: 100%; border-collapse: collapse;"> <thead> <tr> <th></th> <th>10%TX</th> <th>50%TX</th> <th>100%TX</th> <th>100%RX</th> <th>Pwr-Down</th> </tr> </thead> <tbody> <tr> <td>AC4424-10:</td> <td>90mA</td> <td>115mA</td> <td>140mA</td> <td>85mA</td> <td>15mA</td> </tr> <tr> <td>AC4424-100:</td> <td>100mA</td> <td>160mA</td> <td>235mA</td> <td>85mA</td> <td>15mA</td> </tr> <tr> <td>AC4424-200:</td> <td>115mA</td> <td>235mA</td> <td>385mA</td> <td>85mA</td> <td>15mA</td> </tr> </tbody> </table>		10%TX	50%TX	100%TX	100%RX	Pwr-Down	AC4424-10:	90mA	115mA	140mA	85mA	15mA	AC4424-100:	100mA	160mA	235mA	85mA	15mA	AC4424-200:	115mA	235mA	385mA	85mA	15mA
	10%TX	50%TX	100%TX	100%RX	Pwr-Down																				
AC4424-10:	90mA	115mA	140mA	85mA	15mA																				
AC4424-100:	100mA	160mA	235mA	85mA	15mA																				
AC4424-200:	115mA	235mA	385mA	85mA	15mA																				
Channels (used to create independent networks)	US/Canada: 40 Channels Europe: 40 Channels France: 20 Channels																								
Security	One byte System ID																								
Interface Buffer Size	Input/Output: 256 bytes each																								
RADIO																									
Frequency Band	US/Canada (10mW, 100mW, 200mW): 2.402 – 2.478 GHz Europe Low Band(100mW): 2.406 – 2.435 GHz Europe High Band(100mW): 2.444 – 2.472 GHz France (100mW): 2.406 – 2.435 GHz																								
Radio Type	Frequency Hopping Spread Spectrum																								
Output Power (conducted, no antenna)	AC4424-10: 10mW typical AC4424-100: 50mW typical AC4424-200: 200mW typical																								
Effective Isotropic Radiated Power (EIRP with 3dBi gain antenna)	AC4424-10: 20mW typical AC4424-100: 100mW typical AC4424-200: 400mW typical																								
Voltage	5V nominal $\pm 2\%$, $\pm 50\text{mV}$ ripple																								
Sensitivity	-90dBm typical @ 576kbps																								
Range (based on 3dBi gain antenna)	AC4424-10: Indoors to 300 ft., Outdoors to 3000 ft. AC4424-100: Indoors to 400 ft., Outdoors to 6000 ft. AC4424-200: Indoors to 500 ft., Outdoors to 10000 ft.																								
ENVIRONMENTAL																									
Temperature (Operating) Industrial:	-40°C to 80°C																								
Temperature (Storage)	-50°C to +85°C																								
Humidity (non-condensing)	10% to 90%																								
PHYSICAL																									
Dimensions	1.65" x 2.65" x 0.20"																								
Antenna	AC4424-10: MMCX Jack or Integral Antenna AC4424-100: MMCX Jack AC4424-200: MMCX Jack																								
Weight	Less than 0.7 ounce																								

3. Specifications

3.1 INTERFACE SIGNAL DEFINITIONS

The AC4424 has a simple interface that allows OEM Host communications with the transceiver. **Table 1 – Pin Definitions**, shows the connector pin numbers and associated functions. The I/O direction is with regard to the transceiver. All I/O is 5VDC TTL level signals except for RSSI. All inputs are weakly pulled High and may be left floating during normal operation.

Table 1 – Pin Definitions

Pin	Type	Signal Name	Function
1		NC	No Connect
2	O	TXD	Transmitted data out of the transceiver
3	I	RXD	Data input to the transceiver
4		NC	No Connect
5	GND	GND	Signal Ground
6	O	Hop Frame	HOP FRAME – Active Low when the transceiver is hopping.
7	O	CTS	Clear to Send – Active Low when the transceiver is ready to accept data for transmission.
8	I	RTS	Request to Send – When enabled in EEPROM, active Low when the OEM Host is ready to accept data from the transceiver. NOTE: Keeping RTS High for too long can cause data loss.
9		NC	No Connect
10	PWR	VCC	5V ± 2%, ± 50mV ripple
11	PWR	VCC	5V ± 2%, ± 50 mV ripple
12	I/O	9600_BAUD/ Packet Frame	9600_BAUD – When pulled logic Low before applying power or resetting the transceiver’s serial interface is forced to a 9600, 8, N, 1 rate. To exit, transceiver must be reset or power-cycled with 9600_Baud logic High. *Note: 9600_BAUD should only be used to recover the radio from an unknown baud rate and should not be used during normal operation. Packet Frame – When programmed in EEPROM, Packet Frame will transition logic Low at the start of a received RF packet and transition logic High at the completion of the packet.
13	O	RSSI	Received Signal Strength Indicator - An analog output giving a relative indication of received signal strength while in Receive Mode.
14	I	WR_ENA	EEPROM Write Enable – When pulled logic Low, it allows the Host to write the on-board EEPROM. Resetting the transceiver with this pin pulled Low may corrupt EEPROM data.
15	I	UP_RESET	RESET – Controlled by the AC4424 for power-on reset if left unconnected. After a Stable power-on (250ms) a 50us logic High pulse will reset the AC4424. Do not power up the transceiver with this pin tied Low.
16	GND	GND	Signal Ground
17	I	Command/Data	When logic Low, transceiver interprets Host data as command data. When logic High, transceiver interprets Host data as transmit data.
18		NC	No Connect
19		NC	No Connect
20	O	IN_RANGE	In Range – Active Low when a Client radio is in range of a Server on same Channel with the same System ID.

I = Input to the transceiver

O = Output from the transceiver

3.2 ELECTRICAL SPECIFICATIONS

Table 2 – DC Input Voltage Characteristics

Pin	Type	Name	High Min.	High Max.	Low Min.	Low Max.	Unit
3	I	RXD	$0.2V_{cc}+0.9$	$V_{cc}+0.5$	-0.5	$0.2V_{cc}-0.1$	V
8	I	RTS	$0.2V_{cc}+0.9$	$V_{cc}+0.5$	-0.5	$0.2V_{cc}-0.1$	V
12	I	9600 Baud	$0.2V_{cc}+0.9$	$V_{cc}+0.5$	-0.5	$0.2V_{cc}-0.1$	V
14	I	WR_ENA	$0.7V_{cc}$	$V_{cc}+1$	-0.3	0.5	V
15	I	UP_RESET	$0.7V_{cc}$	$V_{cc}+0.5$	-0.5	$0.2V_{cc}-0.1$	V
17	I	Command/Data	$0.2V_{cc}+0.9$	$V_{cc}+0.5$	-0.5	$0.2V_{cc}-0.1$	V

Table 3 – DC Output Voltage Characteristics

Pin	Type	Name	High Min.	Low Max.	Unit
2	O	TXD	$V_{cc}-0.7 @ -30\mu A$	$0.4 @ 1.6mA$	V
6	O	Hop Frame	$V_{cc}-0.7 @ -30\mu A$	$0.4 @ 1.6mA$	V
7	O	CTS	$V_{cc}-0.7 @ -30\mu A$	$0.4 @ 1.6mA$	V
12	O	Packet Frame	$V_{cc}-0.7 @ -30\mu A$	$0.4 @ 1.6mA$	V
13	O	RSSI	See Figure 1	See Figure 1	V
20	O	IN_RANGE	$V_{cc}-0.7 @ -30\mu A$	$0.4 @ 1.6mA$	V

3.3 SYSTEM TIMING

Care should be taken when selecting transceiver architecture as it can have serious effects on data rates, latency timings, and Overall System Throughput. The importance of these three characteristics will vary from system to system and should be a strong consideration when designing the system.

3.3.1 Serial Interface Data Rate

The Serial Interface Data Rate is programmable by the Host. This is the rate the Host and transceiver communicate over the serial bus. Possible values range from 110 bps to 288,000 bps. The only supported mode is asynchronous – 8-bit, No Parity, 1 Start Bit, and 1 Stop Bit.

3.3.2 Timing Diagrams

Addressed Acknowledge Mode with Interface Timeout:

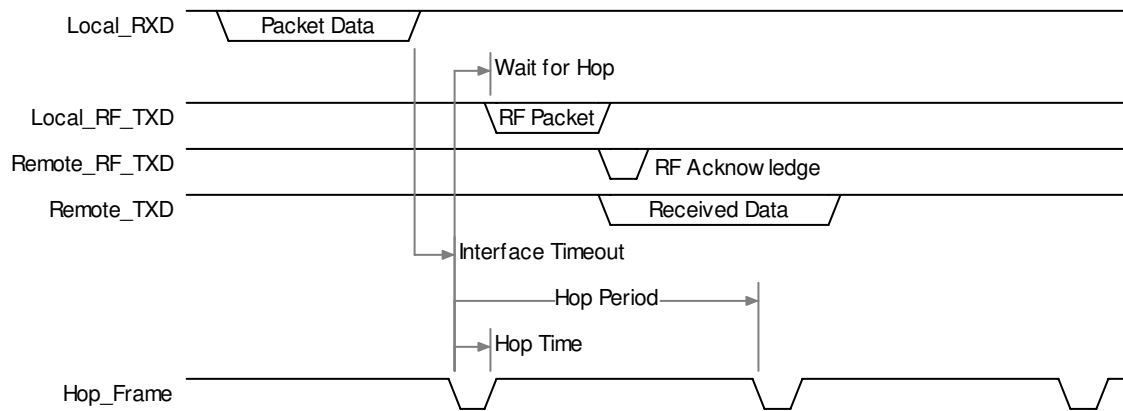

Addressed Acknowledge Mode with No Interface Timeout:

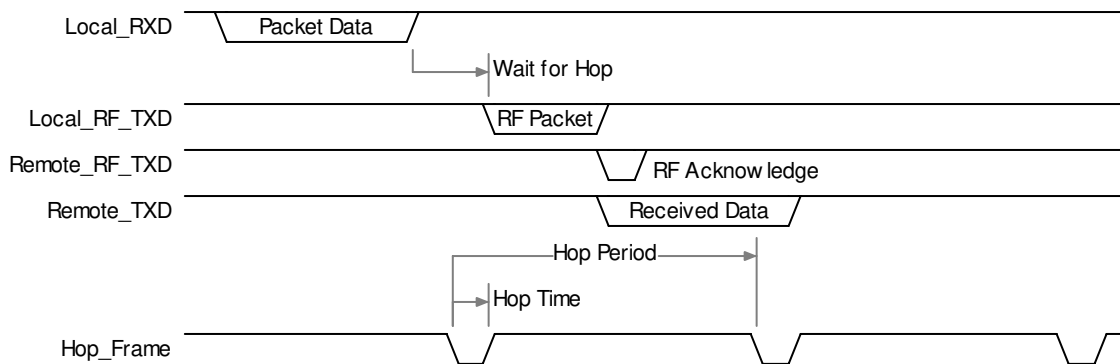

Broadcast Acknowledge Mode with No Interface Timeout:

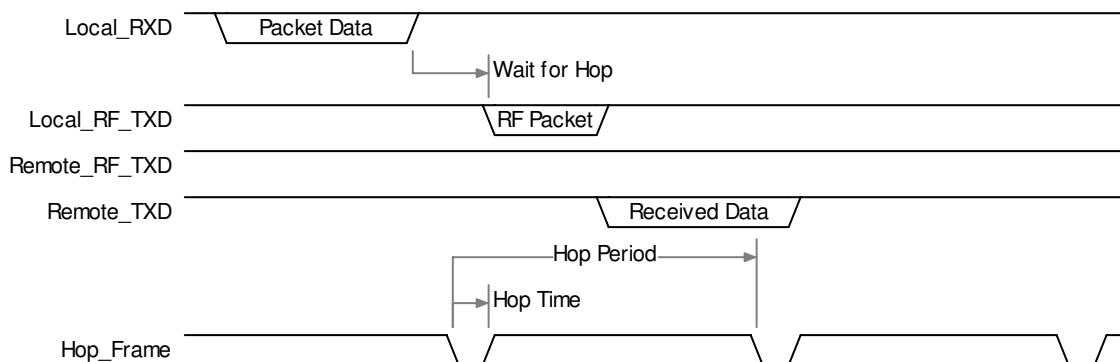

Broadcast Acknowledge Mode with Interface Timeout:

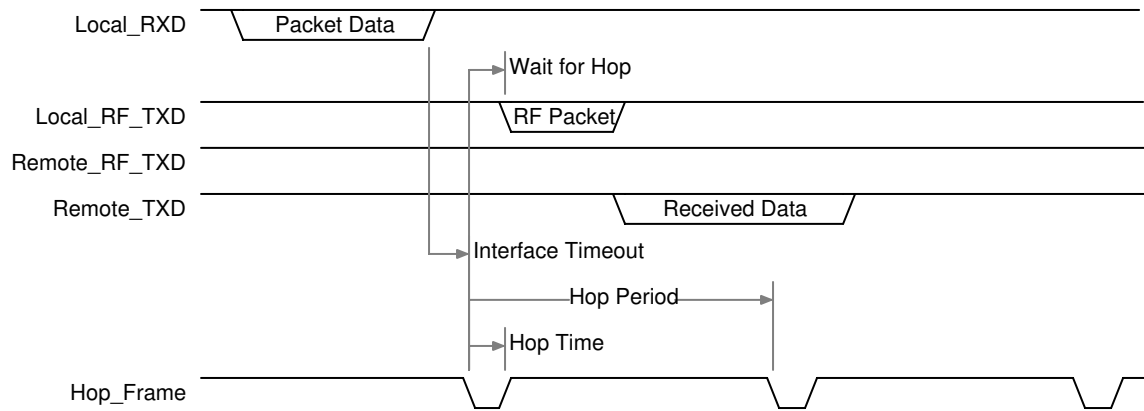

Table 4 – Timing Parameters

Parameter	Typical Time (ms)
Hop Time	1
Hop Period	8

3.3.3 Maximum Overall System Throughput

When configured as shown in the table below, an AC4424 transceiver is **capable** of achieving the listed throughput. However, in the presence of interference or at longer ranges, the transceiver may not be able to meet these specified throughputs.

Table 5 – Maximum Overall System Throughputs

RF Mode	Interface Baud Rate	Duplex	Direction	Throughput (bps)
Acknowledge	115,200	Half	One way	80k
Acknowledge	115,200	Full	Both ways	40k

4. Configuring the AC4424

4.1 EEPROM PARAMETERS

A Host can program various parameters that are stored in EEPROM and become active after a power-on reset. **Table 6 - EEPROM Parameters**, gives the locations and descriptions of the parameters that can be read or written by a Host. Factory default values are also shown. **Do not write to any EEPROM addresses other than those listed below. Do not copy a transceiver's EEPROM data to another transceiver. Doing so may cause the transceiver to malfunction.**

Table 6 – EEPROM Parameters

Parameter	EEPROM Address	Length (Bytes)	Range	Default	Description
Product ID	00H	40			40 bytes - Product identifier string. Includes revision information for software and hardware.
Sub Hop Adjust	36H	1	D0h	D0h	Protocol parameter and should not be changed unless recommended by Aerocomm
Channel Number	40H	1	00 – 27h	00h	See Table 10
Server/Client Mode	41H	1	01 – 02h	02h	01h = Server 02h = Client
Baud Rate Low	42H	1	00 – FFh	05h	Low Byte of the interface baud rate.
Baud Rate High	43H	1	00 – FFh	00h	High Byte of the interface baud rate.
Control 0	45H	1		00010100b (14h)	Settings are: Bit 7 – AeroComm Use Only Bit 6 – AeroComm Use Only Bit 5 – Sync to Channel 0 = Don't Sync to Channel 1 = Sync to Channel Bit 4 – AeroComm Use Only Bit 3 – Packet Frame 0 = Disable Packet Frame 1 = Use pin 12 as Packet Frame Bit 2 – AeroComm Use Only Bit 1 – RF Delivery 0 = Addressed 1 = Broadcast Bit 0 – AeroComm Use Only

Parameter	EEPROM Address	Length (Bytes)	Range	Default	Description
Transmit Retries	4CH	1	01 - FFh	10h	
Broadcast Attempts	4DH	1	01 - FFh	04h	
API Control	56H	1		01000011b = 43h	Settings are: Bit 7 – AeroComm Use Only Bit 6 – RF Architecture 0 = Server-Client 1 = Peer-to-Peer Bit 5 – AeroComm Use Only Bit 4 – Auto Destination 0 = Use Destination Address 1 = Automatically set Destination to Server Bit 3 – AeroComm Use Only Bit 2 – RTS Enable 0 = RTS Ignored 1 = Transceiver obeys RTS Bit 1 – Duplex Mode 0 = Half Duplex 1 = Full Duplex Bit 0 – Auto Config 0 = Use EEPROM values 1 = Auto Configure Values
Interface Timeout	58H	1	01 - FFh	F0h	
Sync Channel	5AH	1	00 - 3Fh	01h	
RF Packet Size	5BH	1	01 - 40h	40h	
CTS On	5CH	1	01 - FFh	C0h	
CTS On Hysteresis	5DH	1	01 - FFh	80h	
Destination ID	70H	6		6 Bytes	
System ID	76H	1	00 - FFh	01h	
MAC ID	80H	6		6 Bytes	Unique IEEE MAC Address
Random Backoff	C3h	1	00 - FFh	00h	00h = Disable Random Backoff 01h = Wait 1-2 packet times, then retry 03h = Wait 1-4 packet times, then retry 07h = Wait 1-8 packet times, then retry 0Fh = Wait 1-16 packet times, then retry 1Fh = Wait 1-32 packet times, then retry 3Fh = Wait 1-64 packet times, then retry 7Fh = Wait 1-128 packet times, then retry FFh = Wait 1-256 packet times, then retry

4.2 CONFIGURING THE AC4424 ¹

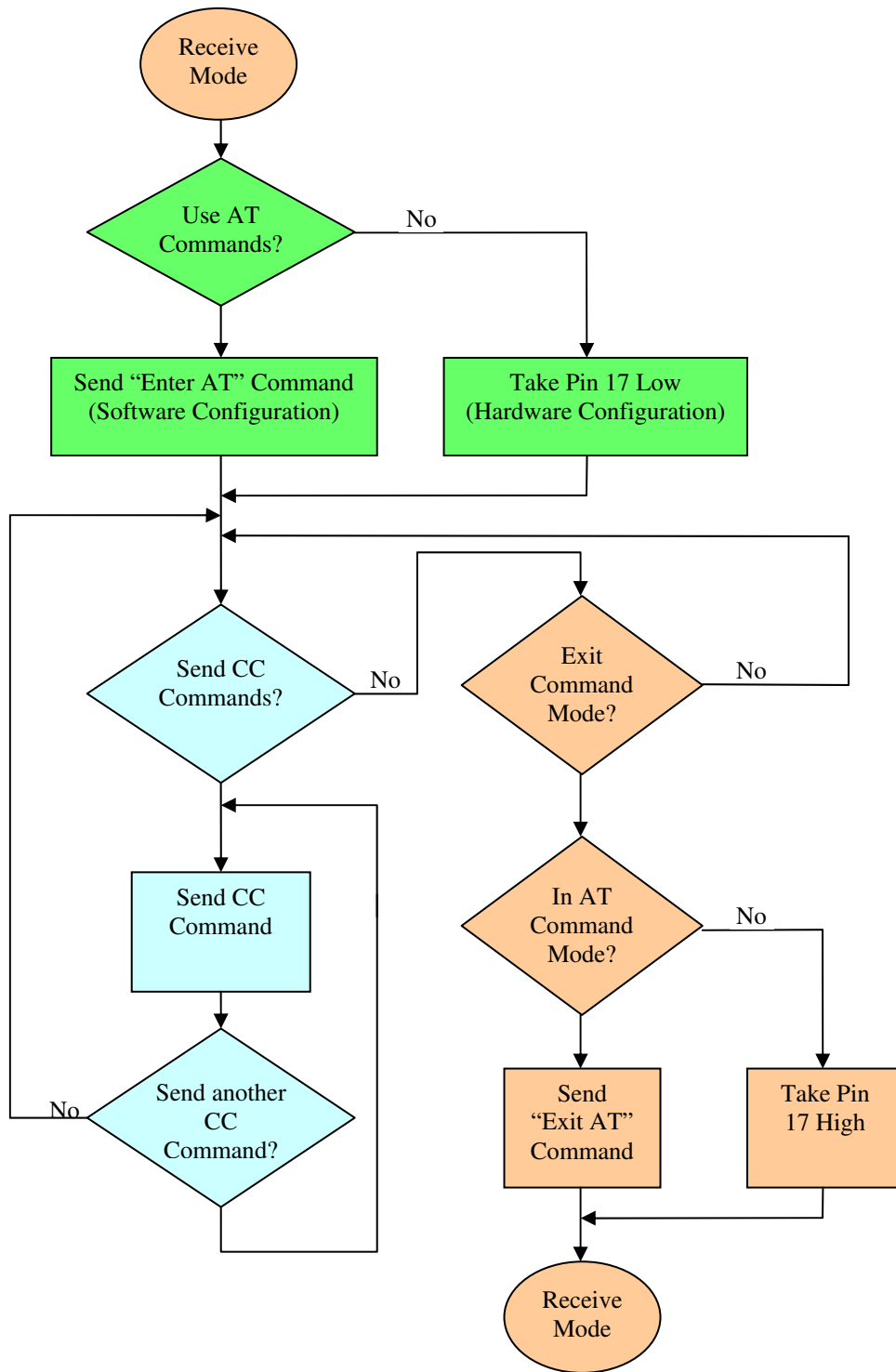

¹ Resetting the AC4424 at any time will exit Configuration or CC Command mode.

4.3 COMMAND REFERENCE

Command Name	Command (All Bytes in Hex)						Return (All Bytes in Hex)			
AT Enter Command Mode	41h	54h	2Bh	2Bh	2Bh	0Dh	CCh	43h	4Fh	4Dh
Exit AT Command Mode	CCh	41h	54h	4Fh	0Dh		CCh	44h	41h	54h
Status Request	CCh	00h	00h	-	-		CCh	Firmware Version	00h: Server In Range 01h: Client In Range 02h: Server Out of Range 03h: Client Out of Range	
Change Channel with Forced Acquisition	CCh	02h	New Channel	-	-		CCh	New Channel	-	-
Server/Client	CCh	03h	00h – Server in Normal Operation 01h – Client in Normal Operation 02h – Server in Acquisition Sync 03h – Client in Acquisition Sync				CCh	Firmware Version	00h – Server in Normal Operation 01h – Client in Normal Operation 02h – Server in Acquisition Sync 03h – Client in Acquisition Sync	
Sync Channel	CCh	05h	New Sync Channel	-	-		CCh	New Sync Channel	-	-
Power-Down	CCh	06h	-	-	-		CCh	Channel	-	-
Power-Down Wake-Up	CCh	07h	-	-	-		CCh	Channel	-	-
Broadcast Mode	CCh	08h	00h: Addressed 01h: Broadcast	-	-		CCh	00h or 01h	-	-
Write Destination Address	CCh	10h	Byte 4 of destination's MAC	Byte 5 of destination's MAC	Byte 6 of destination's MAC		CCh	Byte 4 of destination's MAC	Byte 5 of destination's MAC	Byte 6 of destination's MAC
Read Destination Address	CCh	11h	-	-	-		CCh	Byte 4 of destination's MAC	Byte 5 of destination's MAC	Byte 6 of destination's MAC
EEPROM Byte Read	CCh	C0h	Start Address	Length (01h – 80h)			CCh	Start Address	Length	Data at Addresses
EEPROM Byte Write	CCh	C1h	Address	Length (01h)	Data to be Written		Address	Length (01h)	Data Written	
Soft Reset	CCh	FFh					CCh	FFh		

4.4 AC4424 AT COMMANDS

The AT Command mode implemented in the AC4424 creates a virtual version of the Command/Data pin. The “Enter AT Command Mode” Command asserts this virtual pin Low (to signify Command Mode) and the “Exit AT Command Mode” Command asserts this virtual pin High (to signify Data). Once this pin has been asserted Low, all On-the-Fly CC Commands documented in the manual are supported.

When in AT Command Mode, the user cannot send or receive RF packets. However, an ambiguity of approximately 10ms exists where, if the “Enter AT Command Mode” command has been sent to the transceiver at the same time an RF packet is being received, the RF packet could be sent to the OEM Host before the “Enter AT Command Mode” command response is sent to the OEM Host.

4.4.1 Enter AT Command Mode

Prior to sending the “Enter AT Command Mode” command to the transceiver, the OEM Host must ensure that the RF transmit buffer of the transceiver is empty (if the buffer is not empty, the “Enter AT Command Mode” command will be interpreted as packet data and will be transmitted out over the RF). This can be accomplished by waiting up to one second between the last transmit packet and the AT Command. The OEM Host must also ensure that the RF Packet Size for the transceiver is set to a minimum of six. The Enter AT Command mode command is as follows:

OEM Host Command:

41h	54h	2Bh	2Bh	2Bh	0Dh
-----	-----	-----	-----	-----	-----

Transceiver Response:

CCh	43h	4Fh	4Dh
-----	-----	-----	-----

4.4.2 Exit AT Command Mode

To exit AT Command Mode, the OEM Host should send the following command to the transceiver:

OEM Host Command:

CCh	41h	54h	4Fh	0Dh
-----	-----	-----	-----	-----

Transceiver Response:

CCh	44h	41h	54h
-----	-----	-----	-----

4.5 ON-THE-FLY CONTROL COMMANDS (CC COMMAND MODE)

The AC4424 transceiver contains static memory that holds many of the parameters that control the transceiver operation. Using the “CC” command set allows many of these parameters to be changed during system operation. Because the memory these commands affect is static, when the transceiver is reset, these parameters will revert back to the settings stored in the EEPROM.

While in CC Command mode using pin 17 (Command/Data), the RF interface of the transceiver is still active. Therefore, it can receive packets from remote transceivers while in CC Command mode and forward these to the OEM Host. While in CC Command mode using AT Commands, the RF interface of the transceiver is active, but packets sent from other transceivers will not be received. The transceiver uses **Interface Timeout/RF Packet Size** to determine when a CC Command is complete. Therefore, there should be no delay between each character as it is sent from the OEM Host to the transceiver or the transceiver will not recognize the command. If the OEM Host has sent a CC Command to the transceiver and an RF packet is received by the transceiver, the transceiver will send the CC Command response to the OEM Host before sending the packet. However, if an RF packet is received before the Interface Timeout expires on a CC Command, the transceiver will send the packet to the OEM Host before sending the CC Command response.

When an invalid command is sent, the radio scans the command to see if it has a valid command followed by bytes not associated with the command, in which case the radio discards the invalid bytes and accepts the command. In all other cases, the radio returns the first byte of the invalid command back to the user and discards the rest.

The EEPROM parameters and a Command Reference are available in **Section 4, Configuring the AC4424**, of this manual.

4.5.1 Status Request

The Host issues this command to request the status of the transceiver.

Host Command:

Byte 1 = CCh
Byte 2 = 00h
Byte 3 = 00h

Transceiver Response:

Byte 1 = CCh
Byte 2 = Firmware version number
Byte 3 = Data1

Where:

Data1 =
00 for Server in Normal Operation
01 for Client in Normal Operation
02 for Server in Acquisition Sync
03 for Client in Acquisition Sync

4.5.2 Change Channel with Forced Acquisition Sync

The Host issues this command to change the channel of the transceiver and force the transceiver to actively begin synchronization.

Host Command:

Byte 1 = CCh
Byte 2 = 02h
Byte 3 = RF Channel Number (Hexadecimal)

Transceiver Response:

Byte 1 = CCh
Byte 2 = RF Channel Number (Hexadecimal)

4.5.3 Server/Client

The Host issues this command to change the mode (Server or Client) of the transceiver and can force the transceiver to actively begin synchronization.

Host Command:

Byte 1 = CCh
Byte 2 = 03h
Byte 3 = Data1

Where:

Data1 =
00 for Server in Normal Operation
01 for Client in Normal Operation
02 for Server in Acquisition Sync
03 for Client in Acquisition Sync

Transceiver Response:

Byte 1 = CCh
Byte 2 = Firmware Version Number
Byte 3 = Data1

Where:

Data1 = Data1 from Host Command

4.5.4 Sync Channel

The Sync Channel command can be sent to a Server that already has Sync-to-Channel enabled. This will change the Server's Sync Channel setting.

Host Command:

Byte 1 = CCh
Byte 2 = 05h
Byte 3 = New Channel to Synchronize to

Transceiver Response:

Byte 1 = CCh
Byte 2 = New Channel to Synchronize to

4.5.5 Power-Down

After the Host issues the power-down command to the transceiver, the transceiver will de-assert the In_Range line after entering power-down. A Client transceiver in power-down will remain in sync with a Server for a minimum of 2 minutes. To maintain synchronization with the Server, this Client transceiver should re-sync to the Server at least once every 2 minutes. This re-sync is accomplished by issuing the **Power-Down Wake-Up Command** and waiting for the In Range line to go active. Once this occurs, the Client transceiver is in sync with the Server and can be put back into power-down.

Host Command:

Byte 1 = CCh

Byte 2 = 06h

Transceiver Response:

Byte 1 = CCh

Byte 2 = RF Channel Number (Hexadecimal)

4.5.6 Power-Down Wake-Up

The Power-Down Wake-Up Command is issued by the Host to bring the transceiver out of power-down mode.

Host Command:

Byte 1 = CCh

Byte 2 = 07h

Transceiver Response:

Byte 1 = CCh

Byte 2 = RF Channel Number (Hexadecimal)

4.5.7 Broadcast Mode

The Host issues this command to change the transceiver operation between **Addressed Mode** and **Broadcast Mode**. If addressed mode is selected the transceiver will send all packets to the radio designated by the **Destination Address** programmed in the transceiver.

Host Command:

Byte 1 = CCh

Byte 2 = 08h

Byte 3 = 00 for addressed mode, 01 for broadcast mode

Transceiver Response:

Byte 1 = CCh

Byte 2 = 00 for addressed mode, 01 for broadcast mode

4.5.8 Write Destination Address

The Host issues this command to the transceiver to change the Destination Address. This is a **very powerful** command that provides the OEM Host with a means for ad-hoc networking. **Only the three Least Significant Bytes of the MAC Address are used for packet delivery.**

Host Command:

Byte 1 = CCh

Byte 2 = 10h

Bytes 3 – 5 = 00 – FFh corresponding to the three LSB's of the destination MAC Address

Transceiver Response:

Byte 1 = CCh

Bytes 2 – 4 = 00 – FFh corresponding to the three LSB's of the destination MAC Address

4.5.9 Read Destination Address

The Host issues this command to the transceiver to read the Destination Address. This is a **very powerful** command that provides the OEM Host with a means for ad-hoc networking. **Only the three Least Significant Bytes of the MAC Address are used for packet delivery.**

Host Command:

Byte 1 = CCh

Byte 2 = 11h

Transceiver Response:

Byte 1 = CCh

Bytes 2 – 4 = 00 – FFh corresponding to the three LSB's of the destination MAC Address

4.5.10 EEPROM Byte Read

Upon receiving this command, a transceiver will respond with the desired data from the address requested by the OEM Host.

OEM Host Command:

Byte 1 = CCh

Byte 2 = C0h

Byte 3 = Start Address

Byte 4 = Length (01 - 80h)

Transceiver Response:

Byte 1 = CCh

Byte 2 = Start Address

Byte 3 = Length

Byte 4...n = Data at requested addresses

4.5.11 EEPROM Byte Write

Upon receiving this command, a transceiver will write the data byte to the address specified but will not echo it back to the OEM Host until the EEPROM write cycle is complete. The write can take as long as 10ms to complete. Following the write cycle, a transceiver will transmit the data byte to the OEM Host. Multiple byte EEPROM writes are not allowed.

Caution: The maximum number of write cycles that can be performed is 100,000.

OEM Host Command:

Byte 1 = CCh
Byte 2 = C1h
Byte 3 = Address
Byte 4 = Length (01h)
Byte 5...n = Data to store at Address

Transceiver Response:

Byte 1 = Address
Byte 2 = Length (01h)
Byte 3 = Data byte written by this command

4.5.12 Reset

The OEM Host issues this command to perform a soft reset of the transceiver (same effect as using the Reset pin). Any transceiver settings modified by CC Commands (excluding EEPROM writes) will be overwritten by values stored in the EEPROM.

OEM Host Command:

Byte 1 = CCh
Byte 2 = FFh

Transceiver Response:

Byte 1 = CCh
Byte 2 = FFh

5. Theory of Operation

5.1 HARDWARE INTERFACE

Below is a description of all hardware pins used to control the AC4424.

5.1.1 TXD (Transmit Data) and RXD (Receive Data) (pins 2 and 3 respectively)

The AC4424 accepts 5V TTL level asynchronous serial data in the RXD pin and interprets that data as either Command Data or Transmit Data. Data is sent from the transceiver to the OEM Host via the TXD pin. The data must be of the format 8-N-1 (8 data bits, No Parity bits, One stop bit).

5.1.2 Hop Frame (pin 6)

The AC4424 is a frequency hopping spread spectrum radio. Frequency hopping allows the system to hop around interference in order to provide a better wireless link. Hop Frame transitions logic Low at the start of a hop and transitions logic High at the completion of a hop. The OEM Host is not required to monitor Hop Frame.

5.1.3 CTS Handshaking (pin 7)

The AC4424 has an interface buffer size of 256 bytes. If the buffer fills up and more bytes are sent to the transceiver before the buffer can be emptied, data corruption will occur. The transceiver prevents this corruption by asserting CTS High as the buffer fills up and taking CTS Low as the buffer is emptied. **CTS On** in conjunction with **CTS On Hysteresis** control the operation of CTS. CTS On specifies the amount of bytes that must be in the buffer for CTS to be disabled (High). Even while CTS is disabled, the OEM Host can still send data to the transceiver, but it should do so carefully. Once CTS is disabled, it will remain disabled until the buffer is reduced to the size specified by CTS On Hysteresis. The following equation should always be used for setting CTS On, CTS On Hysteresis and **RF Packet Size**:

$$\text{CTS On} - \text{CTS On Hysteresis} = \text{RF Packet Size}$$

5.1.4 RTS Handshaking (pin 8)

With **RTS Mode** disabled, the transceiver will send any received packet to the OEM Host as soon as the packet is received. However, some OEM Hosts are not able to accept data from the transceiver all of the time. With RTS Mode Enabled, the OEM Host can keep the transceiver from sending it a packet by disabling RTS (logic High). Once RTS is enabled (logic Low), the transceiver can send packets to the OEM Host as they are received. **Note: Leaving RTS disabled for too long can cause data loss once the transceiver's receive buffer fills up.**

5.1.5 9600 Baud/Packet Frame (pin 12)

9600_BAUD – When pulled logic Low before applying power or resetting, the transceiver’s serial interface is forced to a 9600, 8-N-1 (8 data bits, No parity, 1 stop bit) rate. To exit, transceiver must be reset or power-cycled with 9600_Baud logic High.

9600_BAUD should only be used to recover the radio from an unknown baud rate and should not be used during normal operation. When 9600_BAUD is pulled logic Low, Broadcast Mode is disabled.

Packet Frame – When enabled in EEPROM, Packet Frame will transition logic Low at the start of a received RF packet and transition logic High at the completion of the packet.

5.1.6 RSSI (pin 13)

Received Signal Strength Indicator is used by the Host as an indication of instantaneous signal strength at the receiver. The Host must calibrate RSSI without a RF signal being presented to the receiver. Calibration is accomplished by following the steps listed below to find a minimum and maximum voltage value.

- 1) Power up only one Client (no Server) transceiver in the coverage area.
- 2) Measure the RSSI signal to obtain the minimum value with no other signal present.
- 3) Power up a Server. Make sure the two transceivers are in close proximity and measure the Client’s peak RSSI once the Client reports In Range to obtain a maximum value at full signal strength.

Figure 1 shows approximate RSSI performance. There are two versions of receivers used by the AC4424. As of January of 2003 forward, only the new revision receiver will be shipped. The RSSI pin of the former revision requires the Host to provide a 27kΩ pull-down to ground. A table of board revision history is provided below. **No RSSI pull-down should be used with the new revision.**

Figure 1 - RSSI Voltage vs. Received Signal Strength

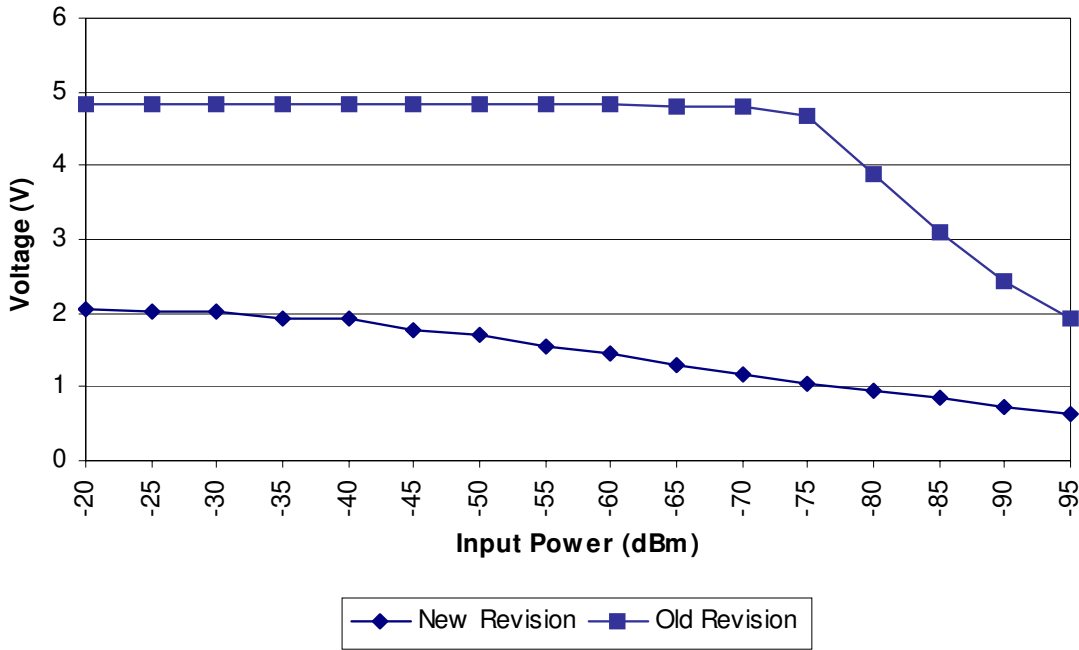

Table 7 – RSSI Board Rev History

Radio Type	Old RSSI Board Number	New RSSI Board Number
AC4424-10	0050-00025	0050-00036
AC4424-10A	N/A	0050-00029
AC4424-100	N/A	0050-00037 or 0050-00075
AC4424-200	0050-00030	0050-00045

5.1.7 *Wr_ENA(EEPROM Write Enable) (pin 14)*

Wr_ENA is a direct connection to the Write Enable line on the EEPROM. When logic Low, the EEPROM's contents may be changed. When logic High, the EEPROM is protected from accidental and intentional modification. It is recommended that this line only be Low when an EEPROM write is desired to prevent unintentional corruption of the EEPROM.

5.1.8 UP_RESET (pin 15)

UP_RESET provides a direct connection to the reset pin on the AC4424 microprocessor. To guarantee a valid power-up reset, this pin should never be tied Low on power-up. For a valid power-on reset, reset must be High for a minimum of 50us.

5.1.9 Command/Data (pin 17)

When logic High, transceiver interprets Host data as transmit data to be sent to other transceivers and their Hosts. When logic Low, transceiver interprets Host data as command data (**see Section 4, Configuring the AC4424**).

5.1.10 In Range (pin 20)

The IN_RANGE pin at the connector will be driven logic Low when a Client is in range of a Server on the same **RF Channel** and **System ID**. If a Client cannot hear a Server for 5s, it will drive the IN_RANGE pin logic High and enter a search mode looking for a Server. As soon as it detects a Server, the IN_RANGE pin will be driven logic Low. A Server Host can determine which Clients are in range by the Server's Host software polling a Client's Host.

5.2 SOFTWARE PARAMETERS

Below is a description of all software parameters used to control the AC4424.

5.2.1 RF Architecture (Server-Client/Peer-to-Peer)

The Server controls the system timing by sending out regular beacons (transparent to the transceiver Host), which contain system timing information. This timing information synchronizes the Client radios to the Server.

Each network should consist of only one Server. There should never be two Servers on the same **RF Channel Number** in the same coverage area, as the interference between the two Servers will severely hinder RF communications.

In Server-Client architecture, the Server communicates with the Clients and the Clients **only** communicate with the Server. Enabling **Peer-to-Peer Mode** will allow all radios on the network to communicate with each other. **Note: All transceivers on the same network must have the same setting for Peer-to-Peer and there must still be one, and only one, Server present in a Peer-to-Peer network.**

5.2.2 RF Mode

Acknowledge Mode

In Addressed Acknowledge Mode, the RF packet is sent out to the receiver designated by the **Destination Address**. **Transmit Retries** is used to increase the odds of successful delivery to the intended receiver. Transparent to the OEM Host, the sending transceiver will send the RF packet to the intended receiver. If the receiver receives the packet free of errors, it will tell the sender. If the sender does not receive this acknowledge, it will assume the packet was never received and retry the packet. This will go on until the packet is successfully received or the transmitter exhausts all of its retries. The received packet will only be sent to the OEM Host if and when it is received free of errors.

In Broadcast Acknowledge Mode, the RF packet is broadcast out to all eligible receivers on the network. In order to increase the odds of successful delivery, **Broadcast Attempts** are used to increase the odds of successful delivery to the intended receiver(s). Transparent to the OEM Host, the sending transceiver will send the RF packet to the intended receiver. If the receiver detects a packet error, it will throw out the packet. This will go on until the packet is successfully received or the transmitter exhausts all of its attempts. Once the receiver successfully receives the packet it will send the packet to the OEM Host. It will throw out any duplicates caused by further Broadcast Attempts. The received packet will only be sent to the OEM Host if it is received free of errors.

5.2.3 Random Back Off

Random Back Off – If multiple AC4424 transceivers try to send packets out over the RF at the exact same time, the packets will collide and will not be received by the intended receiver. In fact, if after a collision occurs, both transceivers retry at the same time, the retry will also fail. To avoid further collisions, a transceiver can be programmed to wait a random number of packet times (hops) before resending its data. The amount of randomness is controlled by this parameter. Keep in mind that selecting a larger value for Random Back Off will increase the overall latency of the AC4424. The latency calculation becomes:

Worst Case Latency = 8ms Hop * # of retries * Maximum Random Value

[multiply by 16ms if using Full Duplex mode]

Latency is a very important consideration when using a wireless device. The AC4424 has a 256 byte interface buffer. If, due to latency, the radio cannot send the data out over the RF as fast as data is coming into the radio over the serial interface, the buffer will eventually fill up. If data continues coming into the radio once the buffer is full, the buffer will overflow and the new incoming data will be lost. It is strongly recommended that the radio host monitor the CTS pin to avoid this situation. The transceiver asserts this pin high as the buffer is filling to signal the OEM Host to stop sending data. The transceiver will take CTS Low once the buffer becomes less full.

Random Backoff Settings:

- 00h – Wait 1 packet time, then retry (Random Back Off is disabled)
- 01h – Wait 1 – 2 packet times, then retry
- 03h – Wait 1 – 4 packet times, then retry
- 07h – Wait 1 – 8 packet times, then retry
- 0Fh – Wait 1 – 16 packet times, then retry
- 1Fh – Wait 1 – 32 packet times, then retry
- 3Fh – Wait 1 – 64 packet times, then retry
- 7Fh – Wait 1 – 128 packet times, then retry
- FFh – Wait 1 – 256 packet times, then retry

5.2.4 Sub Hop Adjust

Sub Hop Adjust is an AC4424 protocol parameter and its settings are as follows:

Table 8 – Sub Hop Adjust Settings

RF Mode	Sub Hop Adjust
Acknowledge	D0h

5.2.5 Duplex Mode

In Half Duplex mode, the AC4424 will send a packet out over the RF when it can. This can cause packets sent at the same time by a Server and a Client to collide with each other over the RF. To prevent this, Full Duplex Mode can be enabled. This mode restricts Clients to transmitting on odd numbered frequency “bins” and the Server to transmitting on even frequency bins. Though the RF hardware is still technically half duplex, it makes the radio seem full duplex. This can cause overall throughputs to be cut in half. **Note: All transceivers on the same network must have the same setting for Full Duplex.**

5.2.6 Interface Timeout/RF Packet Size

Interface timeout, in conjunction with **RF Packet Size**, determines when a buffer of data will be sent out over the RF as a complete RF packet based on whichever condition occurs first.

Interface Timeout – Interface Timeout specifies a maximum byte gap in between consecutive bytes. When that byte gap is exceeded, the bytes in the transmit buffer are sent out over the RF as a complete packet. Interface timeout is adjustable in 160uS decrements. The actual timeout created by Interface Timeout is equal to the 2's complement of Interface Timeout times 160uS. The default value for Interface Timeout is F0H or 2.56ms.

RF Packet Size – When the amount of bytes in the transceiver transmit buffer equals RF Packet Size, those bytes are sent out as a complete RF packet.

5.2.7 Serial Interface Baud Rate

This two-byte value determines the baud rate used for communicating over the serial interface to a transceiver. **Table 9 - Baud Rate** lists values for some common baud rates. Baud rates below 110 baud are not supported. For a baud rate to be valid, the calculated baud rate must be within $\pm 3\%$ of the OEM Host baud rate. **If the 9600 BAUD pin (Pin 12) is pulled logic Low at reset, the baud rate will be forced to 9,600.** For Baud Rate values other than those shown in **Table 9 - Baud Rate**, the following equation can be used:

$$\text{BAUD} = (18.432\text{E}+06 / (32 * \text{desired baud rate}))$$

BaudH = High 8 bits of BAUD (base16)

BaudL = Low 8 bits of BAUD (base16)

Table 9 – Baud Rate

Baud Rate	BaudL (42h)	BaudH (43h)	Minimum Interface Timeout (58h)
288,000	02h	00h	FFh
192,000	03h	00h	FFh
115,200	05h	00h	FEh
57,600	0Ah	00h	FDh
38,400	0Fh	00h	FCh
28,800	14h	00h	FBh
19,200	1Eh	00h	F9h
14,400	28h	00h	F7h
9,600	3Ch	00h	F2h
4800	78h	00h	E5h
2400	F0h	00h	CBh
1200	E0h	01h	97h
300	80h	07h	01h
110	74h	14h	01h

5.2.8 Network Topology

RF Channel Number – RF Channel Number provides a physical separation between co-located networks. The AC4424 is a spread spectrum frequency hopping radio with a fixed hopping sequence. Without synchronizing the different networks to each other, different channel numbers could possibly interfere with each other and create “cross-talk.” To avoid cross-talk interference, co-located networks should use **Sync-to-Channel**. A Server radio with Sync-to-Channel enabled will synchronize its frequency hop timing to a system located on the RF Channel specified by **Sync Channel**. The only requirement is that Sync Channel be numerically less than RF Channel. Therefore, every co-located network will be synchronizing to the network with the lowest RF Channel. Five Channel sets are provided for the AC4424. Frequency Offset and Country Code are protocol parameters used to satisfy unique international requirements. **Co-located networks must use the same Channel Set. Channel sets 4 and 5 are only supported in firmware versions 3.0 and higher.**

Table 10 – US and International RF Channel Number Settings

Channel Set	RF Channel Number Range (40h)	Frequency Range	Countries
0	00h – 0Fh	2402 – 2478MHz	10mW, 200mW: US,Canada
1	10h – 1Fh		
2	20h – 2Fh		
3	00h – 13h	2406 – 2435MHz	100mW: Europe,France,US,Canada
4	14h – 27h	2444 – 2472MHz	100mW: Europe,US,Canada

System ID – System ID is similar to a password character or network number and makes network eavesdropping more difficult. A receiving radio will not go in range of or communicate with another radio on a different System ID.

5.2.9 Auto Config

The AC4424 has several variables that control its RF performance and vary by **RF Mode** and **RF Architecture**. Enabling Auto Config will bypass the value for these variables stored in EEPROM and use predetermined values for the given Interface Baud Rate. **Auto Config has been optimized for 115,200 baud Acknowledge Mode and all lower baud rates. It should only be disabled with recommendation from AeroComm.** Below is a list containing some of the variables affected by Auto Config and their respective values:

Table 11 – Auto Config Parameters

Description ²	EEPROM Address	Default	Acknowledge Mode
	47	5	5
	48	60	60
	4E	8	9
	50	FD	FD
	51	2	2
	52	0	0
	53	E4	E4
	54	5	5
	55	50	50
	57	7	7
	59	4	4
RF Packet Size	5B	40	40
CTS On	5C	C0	C0
CTS Hysteresis	5D	80	80
	5E	0E	0E
	5F	3	3

² Parameters without a Description are undocumented protocol parameters and should only be modified to a value other than shown in this table when recommended by AeroComm.

6. Dimensions

All AC4424 products measure 1.65"W x 2.65"L. Critical parameters are as follows:

- **J1** – 20 pin OEM interface connector (Samtec TMM-110-01-L-D-SM, mates with Samtec SMM-110-02-S-D)
- **MMCX Jack** – Antenna connector (Johnson Components P/N 135-3711-822) mates with any manufacturer's MMCX plug

Figure 2 – AC4424 with MMCX

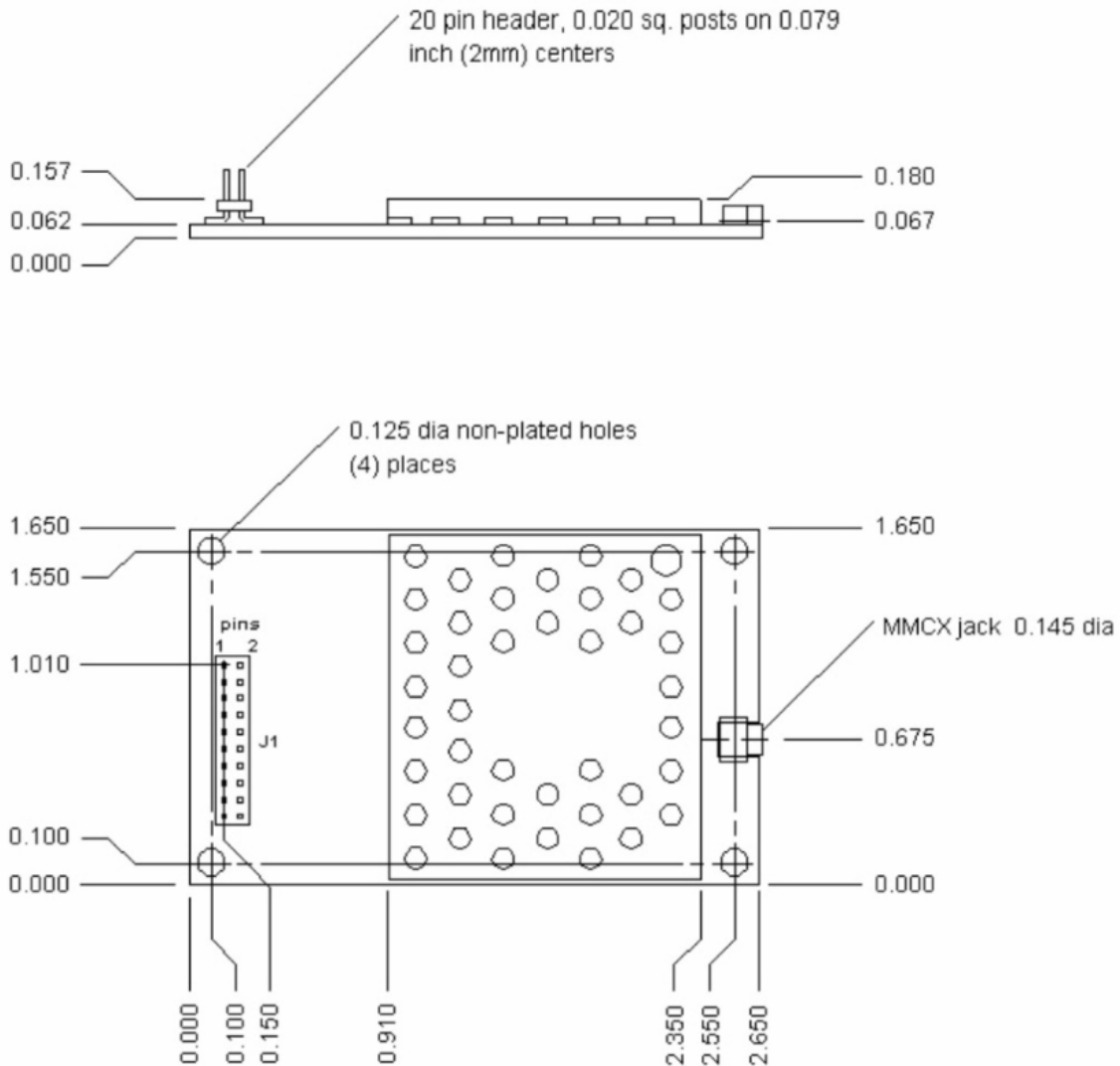
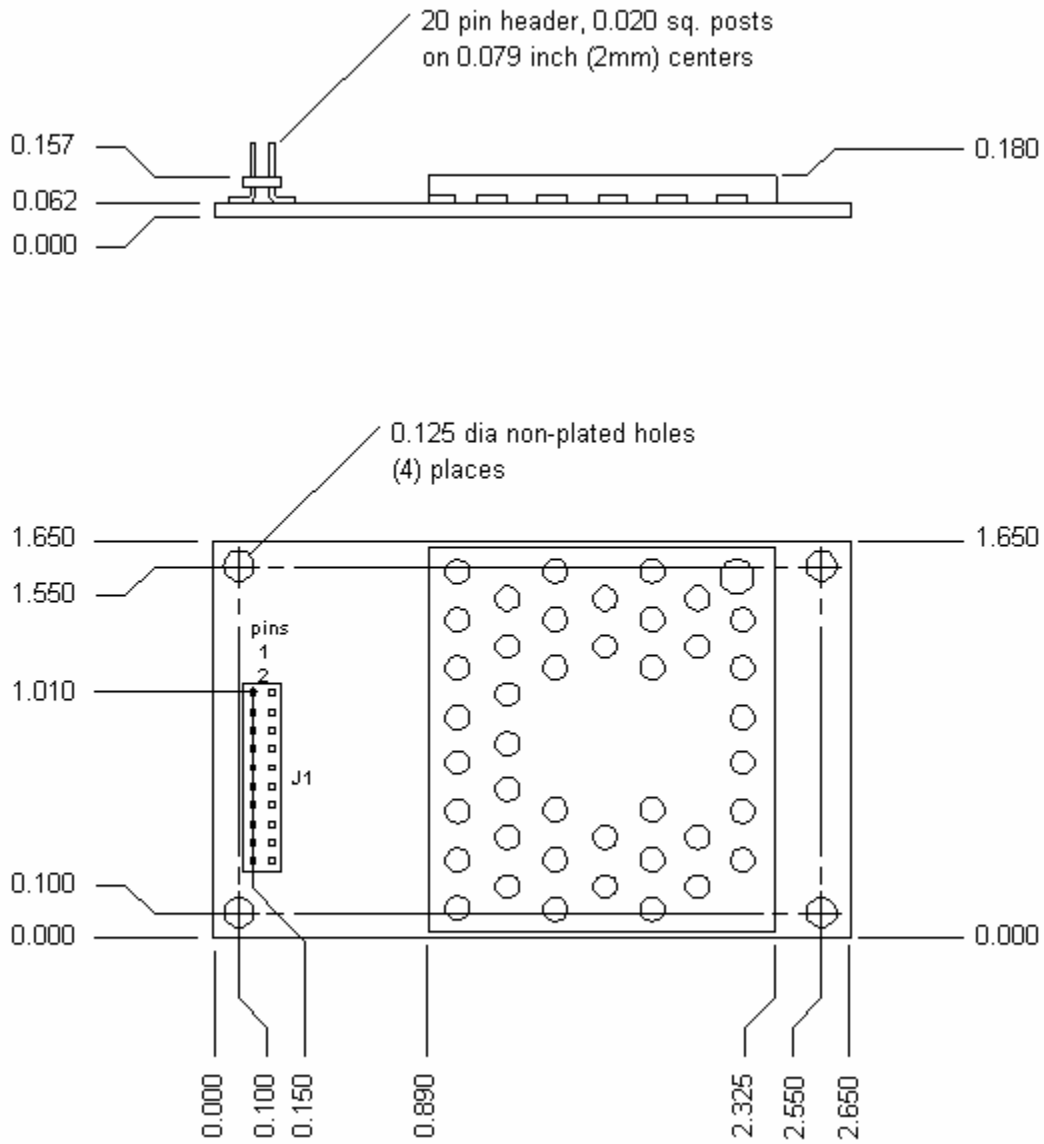

Figure 3 – AC4424 with Integral Antenna



7. Ordering Information

7.1 PRODUCT PART NUMBERS

AC4424-10: AC4424 with 10mW output power, interface data rates to 288Kbps, MMCX antenna connector, -40°C to 80°C

AC4424-10A: AC4424 with 10mW output power, interface data rates to 288Kbps, integral microstrip antenna, -40°C to 80°C

AC4424-100: AC4424 with 50mW output power, interface data rates to 288Kbps, MMCX antenna connector, -40°C to 80°C

AC4424-200: AC4424 with 200mW output power, interface data rates to 288Kbps, MMCX antenna connector, -40°C to 80°C

7.2 DEVELOPER KIT PART NUMBERS

SDK-4424-10: Includes (2) AC4424-10 transceivers, (2) RS232 Serial Adapter Boards, (2) 6Vdc unregulated power supplies, (2) Serial cables, (2) S151FL-5-RMM-2450S dipole antennas with 5" pigtail and MMCX connector, configuration/testing software, Integration engineering support

SDK-4424-10A: Includes (2) AC4424-10A transceivers, (2) RS232 Serial Adapter Boards, (2) 6Vdc unregulated power supplies, (2) Serial cables, configuration/testing software, Integration engineering support

SDK-4424-100: Includes (2) AC4424-100 transceivers, (2) RS232 Serial Adapter Boards, (2) 6Vdc unregulated power supplies, (2) Serial cables, (2) S151FL-5-RMM-2450S dipole antennas with 5" pigtail and MMCX connector, configuration/testing software, Integration engineering support

SDK-4424-200: Includes (2) AC4424-200 transceivers, (2) RS232 Serial Adapter Boards, (2) 6Vdc unregulated power supplies, (2) Serial cables, (2) S151FL-5-RMM-2450S dipole antennas with 5" pigtail and MMCX connector, configuration/testing software, Integration engineering support

8. Regulatory Information

Agency Identification Numbers

Part Number	US/FCC	CAN/IC	EUR/EN
AC4424-10	KQL-PKLR2400	CAN2268391158A	
AC4424-100	KQL-AC4424	CAN2268C391190A	CE
AC4424-200	KQL-PKLR2400-200	CAN2268391180A	

8.1 FCC

The user is responsible for all labeling and ensuring the module complies with FCC regulations (see 47CFR2 for exact regulations).

- The FCC identifier proceeded by “FCC ID:” and the FCC Notice found below must be clearly visible on the outside of the equipment.
- The RF Exposure Warning (next page) also must be printed inside the equipment's user manual.

The FCC/IC approval was granted with the module classified as mobile (ie. the antenna is >20 cm from the human body with the exception of hands, wrists, feet, and ankles). The end user needs to ensure that the antenna location complies with this or retest for portable classification (less than 2.5 cm with the same exceptions as mobile) at their own expense.

FCC regulations allow the use of any antenna of the same type and of equal or less gain. However the antenna is still required to have a unique antenna connector such as MMCX or reverse SMA. On the following page is a table of antennas available through AeroComm. Any different antenna type or antenna with gain greater than those listed must be tested to comply with FCC Section 15.203 for unique antenna connectors and Section 15.247 for emissions at user's expense.

Caution: Any changes or modifications not expressly approved by AeroComm could void the FCC compliancy of the AC4424.

FCC Notice

 **WARNING:** This device complies with Part 15 of the FCC Rules. Operation is subject to the following two conditions: (1) This device may not cause harmful interference, and (2) This device must accept any interference received, including interference that may cause undesired operation.

FCC Labeling Requirements

 **WARNING:** The Original Equipment Manufacturer (OEM) must ensure that FCC labeling requirements are met. This includes a clearly visible label on the outside of the OEM enclosure specifying the appropriate AeroComm FCC identifier for this product as well as the FCC Notice above.

FCC RF Exposure AC4424

 **WARNING:** To satisfy FCC RF exposure requirements for mobile type transmitting devices, a separation distance of 20 cm or more should be maintained between the antenna of this device and persons during operation, with exception of hands wrist, feet, and ankles. To ensure compliance, operations at closer distance than this distance is prohibited.

The preceding statement must be included as a CAUTION statement in manuals for OEM products to alert users on FCC RF Exposure compliance.

8.2 CE

The AC4424-100 is a Class 2 transceiver that is harmonized everywhere except France. Therefore, the end product will have to be marked with a “CE(!)” (the ! is encircled). For complete rules and regulations on labeling in Europe refer to the R&TTE Directive Article 12 and Annex VII.

And the country or countries that the end user intends to sell product in be notified prior to shipping product. Further information about this regulation can be found in Article 6.4 of the R&TTE Directive.

CE regulations allow the use of any antenna of the same type and of equal or less gain. However the antenna is still required to have a unique antenna connector, such as MMCX or reverse SMA. On the following page is a table of antenna available through AeroComm. Any different antenna type or antenna with gain greater than those listed must be re-tested to comply standard EN 300 328 at user’s expense.

Caution: Any changes or modifications not expressly approved by AeroComm could void the CE compliancy of the AC4424.

CE Labeling Requirements



WARNING: The Original Equipment Manufacturer (OEM) must ensure that CE labeling requirements are met. This includes a clearly visible label on the outside of the OEM enclosure specifying the appropriate CE marking. Further information can be found in the R&TTE Directive Article 12 and Annex VII.

Regulatory Information

8.3 APPROVED ANTENNA LIST

Item	Part Number	Mfg.	Type	Gain (dBi)	AC4424X-10	AC4424X-100 Europe/France	AC4424X-100 US/Canada	AC4424X-200
1	WCP-2400-MMCX	Centurion	½ Wave Dipole	2	X	X	X	X
2	WCR-2400-SMRP	Centurion	½ Wave Dipole	2	X	X	X	
3	MFB24008RPN	Maxrad	Omni-Directional	8	X			
4	BMMG24000MSMARP12'	Maxrad	Omni-Directional	1	X			
5	BMMG24005MSMARP12'	Maxrad	Omni-Directional	5	X			
6	MP24013TMSMARP12	Maxrad	Panel	13	X			
7	MUF24005M174MSMARP12	Maxrad	Omni-Directional	5	X			
8	MC2400	Maxrad	Patch	2.5	X			
9	NZH2400-MMCX (External)	AeroComm	Microstrip	1	X			X
10	NZH2400-I (Integral)	AeroComm	Microstrip	1	X			X
11	S131CL-5-RMM-2450S	Nearson	½ Wave Dipole	2	X	X	X	X
12	S181FL-5-RMM-2450S	Nearson	½ Wave Dipole	2	X	X	X	X
13	S191FL-5-RMM-2450S	Nearson	½ Wave Dipole	3	X	X	X	X
14	S151FL-5-RMM-2450S	Nearson	Collinear	5	X			X
15	S152AH-2450S	Nearson	Collinear	4			X	
16	S171AH-2450S	Nearson	Collinear	7			X	
17	MLPV1700	Maxrad	Omni-Directional	4	X			
18	R380.500.127	Radial Larsen	¼ Wave Dipole	2	X	X	X	X
19	ANT-DB1-RMS-RPS	Linx	Monopole	3		X	X	
20	ANT-DB2-916/2.4-RP-SMA	Linx	Dual Band Patch	3		X	X	
21	ANT-YG12-N	Linx	Yagi	12			X	