

DO NOT SCALE FROM THIS PRINT

DESIGNED & DIMENSIONED IN INCHES[MILLIMETERS]

PRF18-J-C-EP-086-SS

SERIES
-18: 1.85 mm

GENDER
-J: JACK

TYPE
-C: CABLE

FINISH
-EP: 50µ" EXTRA HEAVY GOLD CENTER CONTACT, PASSIVATED OUTER CONTACT

TERMINATION
-S: SOLDER CLAMP

ORIENTATION
-S: STRAIGHT

CABLE TYPE
-086: TEMP FLEX 1001935086

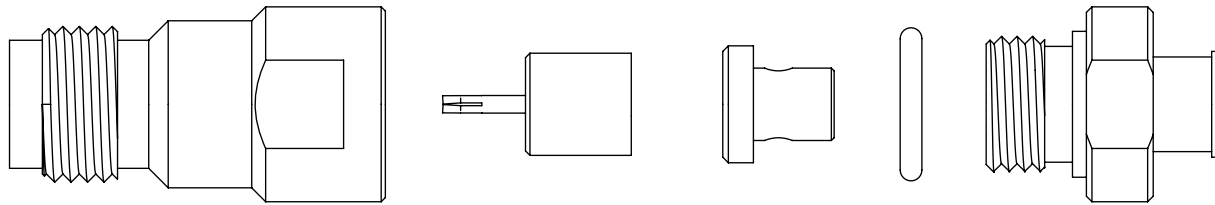
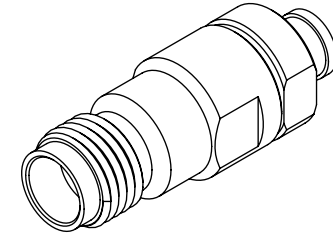
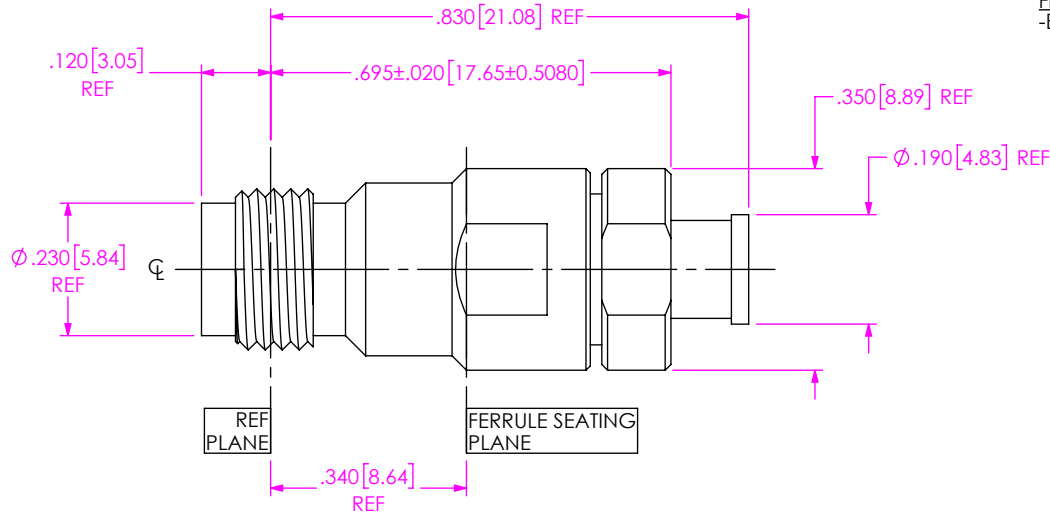

EXPLODED VIEW
NOT TO SCALE
(FOR CLARITY ONLY)

NOTES:

- MATERIAL:
BODY, BUSHING, CLAMP NUT: STAINLESS STEEL.
O-RING: SILICONE RUBBER.
BEAD: PEI.
SOLDER FERRULE: BRASS ALLOY
CONTACT: BERYLLIUM COPPER.
- FINISH:
BODY, BUSHING, CLAMP NUT: PASSIVATED.
CONTACT, SOLDER FERRULE: GOLD OVER NICKEL PLATE,
50 µIN MIN GOLD OVER 50 µIN MIN NICKEL.
- PCI P/N: 4192.

UNLESS OTHERWISE SPECIFIED, DIMENSIONS ARE IN INCHES. TOLERANCES ARE: DECIMALS .XX: ±.01 .XXX: ±.005 .XXXX: ±.0005 ANGLES 1°	* PROPRIETARY NOTE * THIS DOCUMENT CONTAINS CONFIDENTIAL AND PROPRIETARY INFORMATION AND ALL DESIGN, MANUFACTURING, REPRODUCTION, USE, PATENT RIGHTS AND SALES RIGHTS ARE EXPRESSLY RESERVED BY SAMTEC, INC. THIS DOCUMENT SHALL NOT BE DISCLOSED, IN WHOLE OR PART, TO ANY UNAUTHORIZED PERSON OR ENTITY NOR REPRODUCED, TRANSFERRED OR INCORPORATED IN ANY OTHER PROJECT IN ANY MANNER WITHOUT THE EXPRESS WRITTEN CONSENT OF SAMTEC, INC.	 520 PARK EAST BLVD., NEW ALBANY, IN 47150 PHONE: 812-944-6733 FAX: 812-948-5047 e-Mail: info@SAMTEC.com code 55322	
		MATERIAL: DO NOT SCALE DRAWING SHEET SCALE: 3:1	DESCRIPTION: 1.85 MM JACK ASSEMBLY FOR TEMP FLEX 1001935086
		DWG. NO. PRF18-J-C-EP-086-SS	BY: SHERRY W 12/21/2018 SHEET 1 OF 2

CABLE APPLICATION VIEWS

1A. TRIM CABLE TO EXPOSE OUTER BRAID AND DIELECTRIC CORE AS SHOWN.

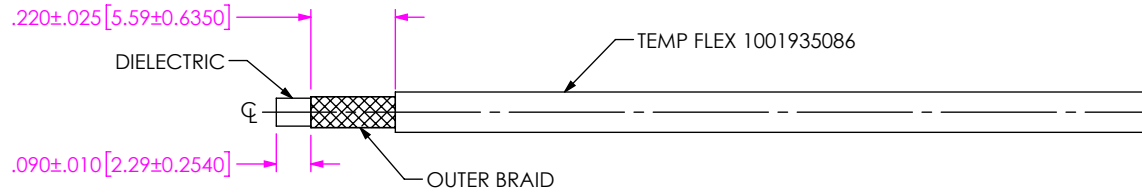

IN-PROCESS VIEW 1

2A. SLIDE CLAMP NUT ONTO CABLE IN ORIENTATION AS SHOWN.
 2B. INSERT CABLE INTO SOLDER FERRULE UNTIL BRAID SEATS IN FERRULE. THEN SOLDER CABLE TO FERRULE WHERE SHOWN.
 2C. TRIM CABLE DIELECTRIC FLUSH WITH FERRULE FACE (DO NOT SCORE CENTER CONDUCTOR). THEN POINT CENTER CONDUCTOR AS SHOWN.

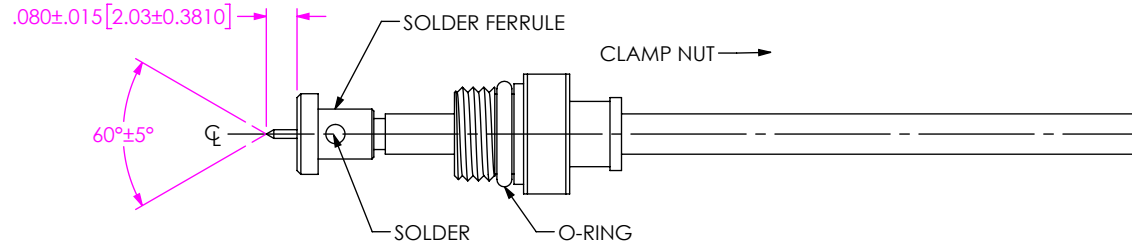

IN-PROCESS VIEW 2

3A. SLIDE CONTACT/BUSHING SUB-ASSEMBLY INTO CONNECTOR HEAD UNTIL SEATED (SLIP FIT).

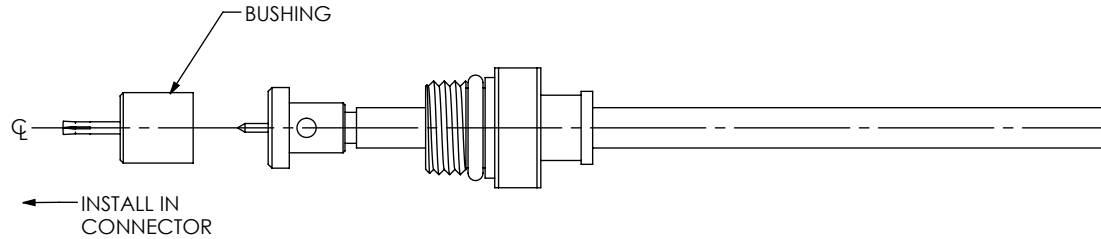

IN-PROCESS VIEW 3

4A. INSERT CABLE SUB-ASSEMBLY INTO CONNECTOR BODY UNTIL SOLDER FERRULE IS SEATED AND TIGHTEN CLAMP NUT TO 25-35 IN-LBS.

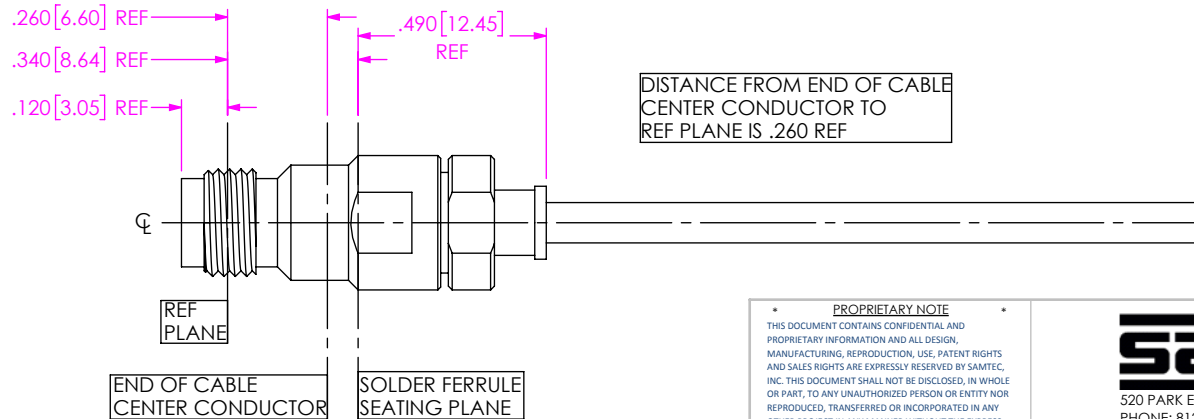

IN-PROCESS VIEW 4

PROPRIETARY NOTE
 THIS DOCUMENT CONTAINS CONFIDENTIAL AND PROPRIETARY INFORMATION AND ALL DESIGN, MANUFACTURING, REPRODUCTION, USE, PATENT RIGHTS AND SALES RIGHTS ARE EXPRESSLY RESERVED BY SAMTEC, INC. THIS DOCUMENT SHALL NOT BE DISCLOSED, IN WHOLE OR PART, TO ANY UNAUTHORIZED PERSON OR ENTITY NOR REPRODUCED, TRANSFERRED OR INCORPORATED IN ANY OTHER PROJECT IN ANY MANNER WITHOUT THE EXPRESS WRITTEN CONSENT OF SAMTEC, INC.



520 PARK EAST BLVD, NEW ALBANY, IN 47150
 PHONE: 812-944-6733 FAX: 812-948-5047
 e-Mail: info@SAMTEC.com code 55322

DO NOT SCALE DRAWING

SHEET SCALE: 2:1

DESCRIPTION: 1.85 MM JACK ASSEMBLY FOR TEMP FLEX 1001935086

DWG. NO. PRF18-J-C-EP-086-SS

BY: SHERRY W 12/21/2018 SHEET 2 OF 2