

SMD Wire Wound Ceramic Chip Inductors IWC0603 Series

APPLICATIONS

Resonant circuits, impedance matching for

- Antenna amplifiers
- Multimedia
- Wireless communication systems

FEATURES

- High resonance frequency
- Narrow inductance tolerance
- Suitable for lead-free reflow soldering
- RoHS-compatible

MATERIAL LIST

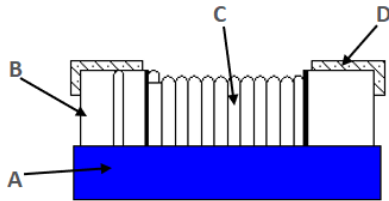

- (A) Epoxy
- (B) Ceramic
- (C) Wire
- (D) Terminal

Part Numbering

IWC	0603	D	24N	R	-3□
Product Series Code	Size Code	Rated Current Code	Inductance Value Code	Packing Code R-Tape&Reel	Additional Description
		A ≤ 100mA B=200mA C=300mA D=400mA E=500mA F=600mA G=700mA H=800mA I=900mA	0N3=0.3nH 6N8=6.8nH 24N=24nH R10=100nH		□-Tolerance Code G - ±2% J - ±5%

Notes

Standard testing conditions , unless otherwise specified

- Temperature: 15 °C to 35 °C
- Humidity: 25% to 85% (RH)
- L、 Q、 SRF : Agilent E4991A+ Agilent 16197A
- Operating Temperature: -40 °C to +125 °C
- Storage Temperature: -10 °C to +40 °C
- Products should be used within 12 months, from the time of delivery
- Cosmetic specification refer to WI-QA-124

CHANGE HISTORY

Rev	Items	Before	After	Owner	Date
A	—	—	—	Xiaolan Du	2021.10.14

1.SPECIFICATION

Part Number	L (nH)	Tolerance	L Test Fre (MHz)	Q Min	Q Test Fre (MHz)	DCR Max (Ω)	Rated current (mA)	SRF (MHz)
IWC0603G22NR-3G	22	2%	250	38	250	0.19	700	3000
IWC0603G22NR-3J	22	5%	250	38	250	0.19	700	3000
IWC0603F27NR-3G	27	2%	250	40	250	0.22	600	2800
IWC0603F27NR-3J	27	5%	250	40	250	0.22	600	2800
IWC0603F33NR-3G	33	2%	250	40	250	0.22	600	2300
IWC0603F33NR-3J	33	5%	250	40	250	0.22	600	2300
IWC0603F39NR-3G	39	2%	250	40	250	0.25	600	2200
IWC0603F39NR-3J	39	5%	250	40	250	0.25	600	2200
IWC0603F47NR-3G	47	2%	200	38	200	0.28	600	2000
IWC0603F47NR-3J	47	5%	200	38	200	0.28	600	2000
IWC0603F68NR-3G	68	2%	200	37	200	0.34	600	1700
IWC0603F68NR-3J	68	5%	200	37	200	0.34	600	1700
IWC0603D82NR-3G	82	2%	150	34	150	0.54	400	1700
IWC0603D82NR-3J	82	5%	150	34	150	0.54	400	1700
IWC0603DR10R-3G	100	2%	150	34	150	0.58	400	1400
IWC0603DR10R-3J	100	5%	150	34	150	0.58	400	1400
IWC0603CR12R-3G	120	2%	150	32	150	0.75	300	1300
IWC0603CR12R-3J	120	5%	150	32	150	0.75	300	1300
IWC0603BR18R-3G	180	2%	100	25	100	1.25	240	990
IWC0603BR18R-3J	180	5%	100	25	100	1.25	240	990
IWC0603BR22R-3G	220	2%	100	25	100	2.02	200	900
IWC0603BR22R-3J	220	5%	100	25	100	2.02	200	900
IWC0603AR27R-3G	270	2%	100	24	100	2.36	170	900
IWC0603AR27R-3J	270	5%	100	24	100	2.36	170	900
IWC0603AR33R-3G	330	2%	100	25	100	3.9	100	900
IWC0603AR33R-3J	330	5%	100	25	100	3.9	100	900

2.Dimensions

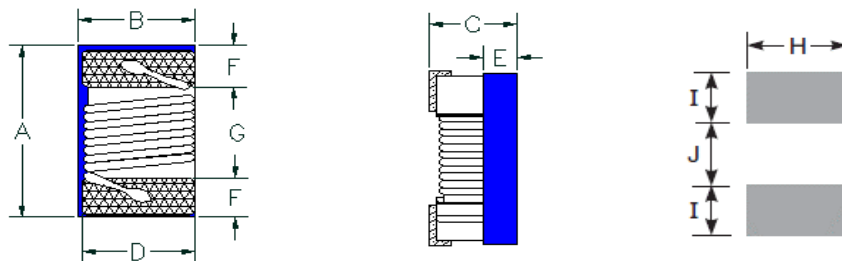

A Max	B Max	C Max	D Ref	E Ref	F Ref	G Ref	H Ref	I Ref	J Ref
1.8	1.12	1.02	0.76	0.5	0.33	0.86	1.02	0.64	0.64

3.CURVES

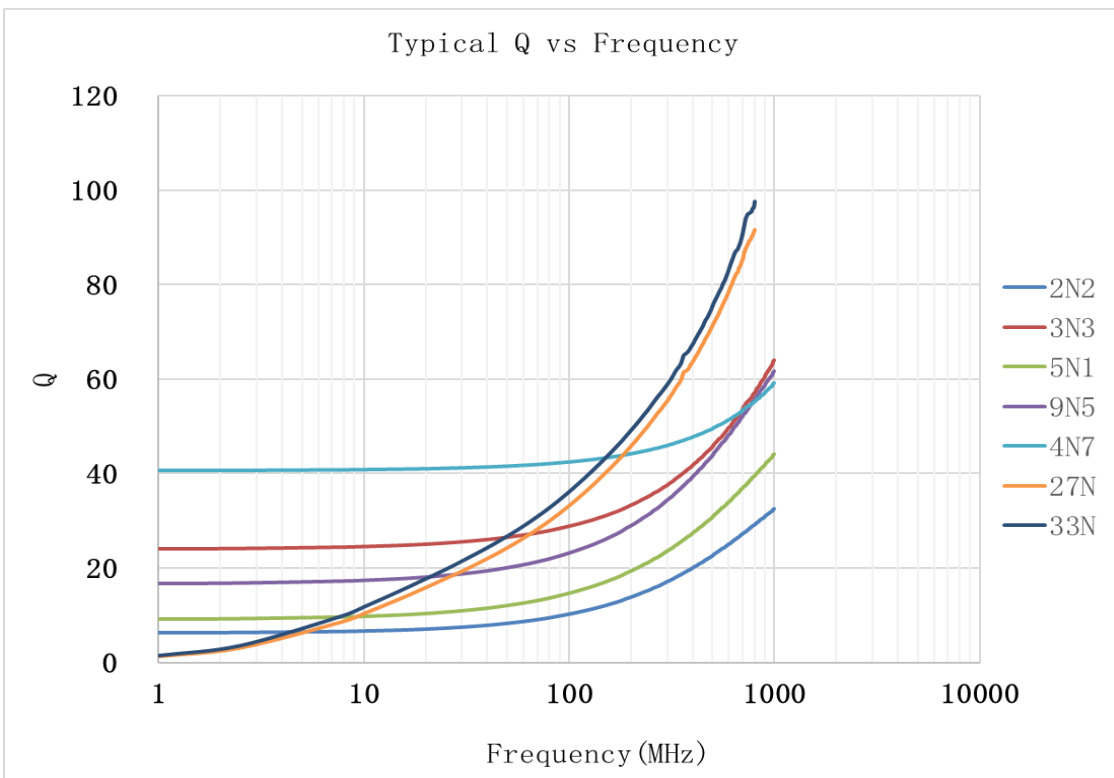
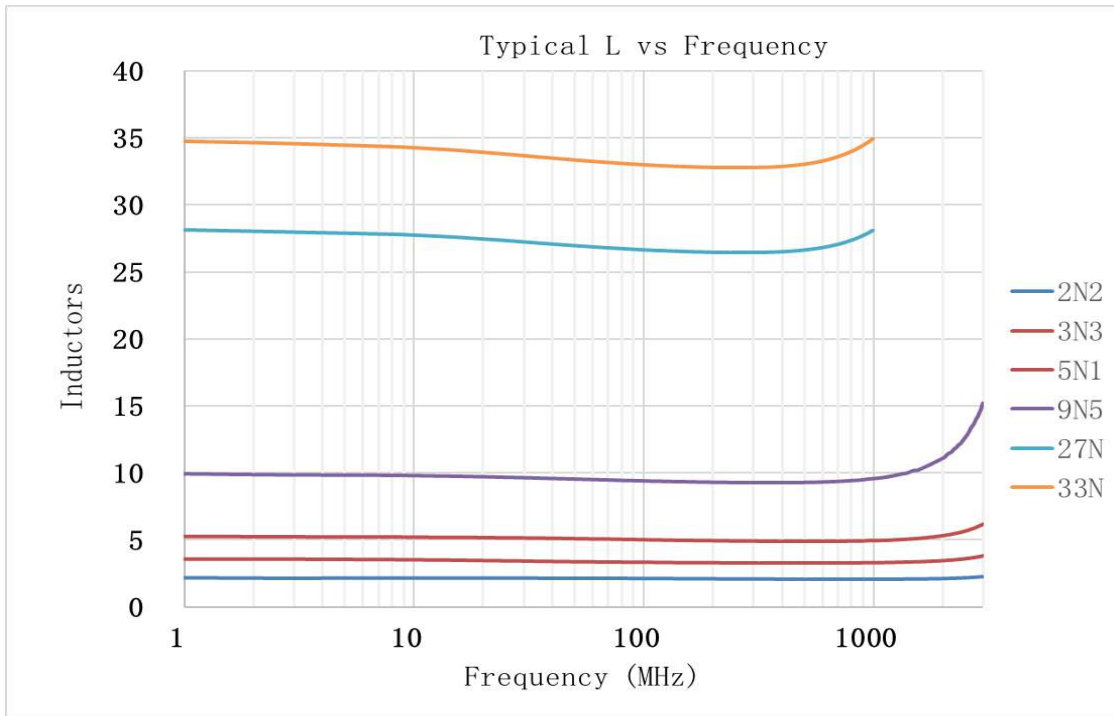

4. SOLDERING

Typical RoHS Reflow Profile

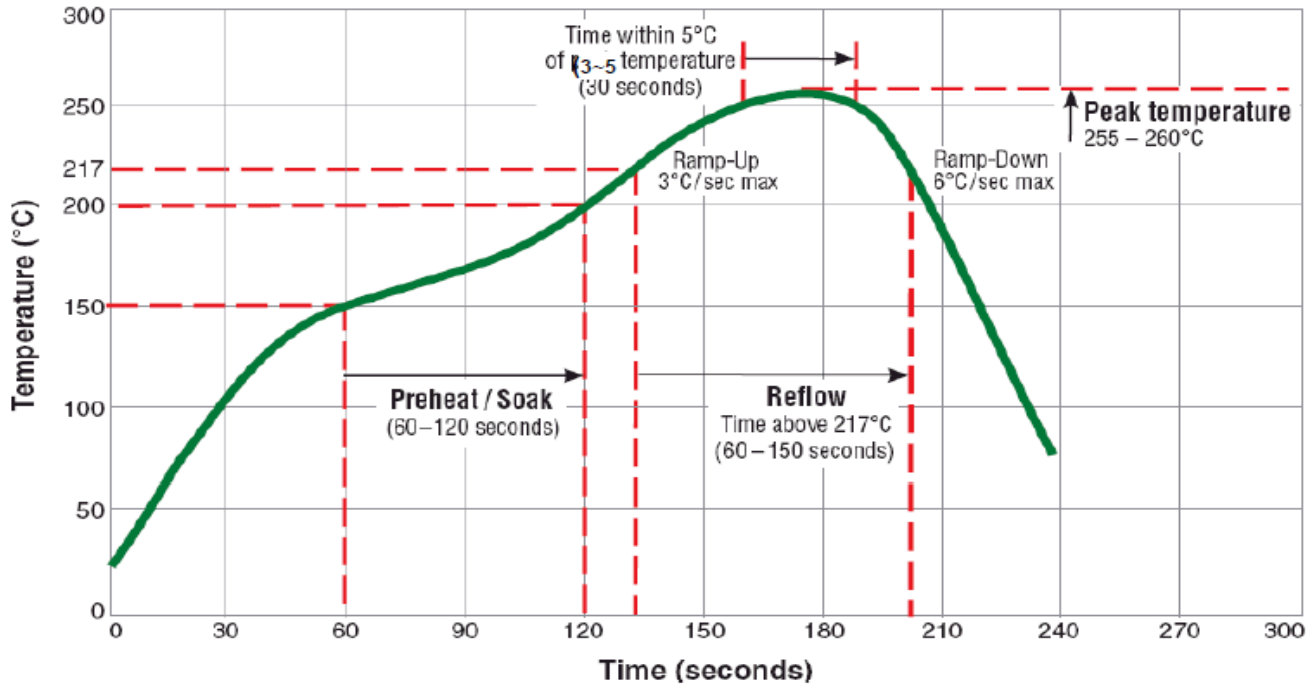

5. PACKAGING

Packaging Style and Quantity

Laird Part Number	Packaging Type	Reel Quantity	Box Quantity
IWC0603 Series	Tape & Reel	4000	20000

Taping Condition (Typ)

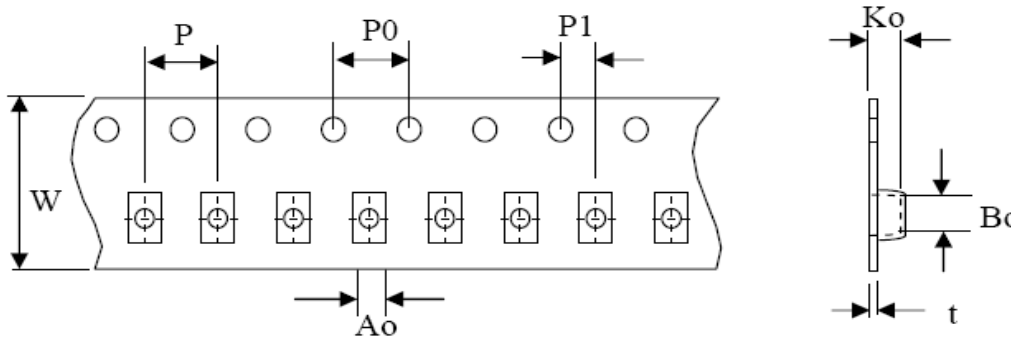

Ao	Bo	T	P	P1
1.16	1.85	0.23	4	2
W	PO	KO		
8	4	0.95		

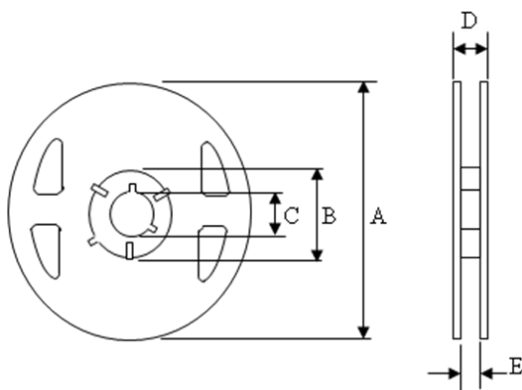

Reel Specifications (Typ)	
A	180
B	60
C	13
D	14.4
E	8.4

Tape Strength

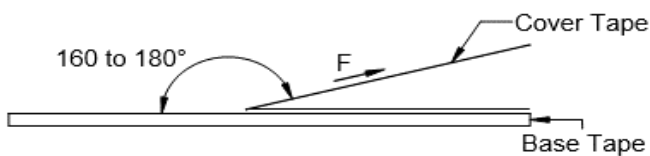

Tape Width	Peeling Force
8 mm	0.1N to 0.6N

6.RELIABILITY

No	Stress	Reference	Additional Requirements
1	High Temperature Exposure (Storage)	MIL-STD-202 Method 108	85±2°C, 168+24hours Inductance:within±10% of initial value
2	Temperature Cycling	JESD22 Method JA-104	-40°C~+85°C, 100cycles Inductance:within±10% of initial value
3	Operational Life	MIL-PRF-27	85°C(Including self-heating), 168hrs, rated current applied(as the part drawing). Inductance:within±10% of initial value
4	External Visual	MIL-STD-883 Method 2009	Inspect device construction, marking and workmanship. Electrical Test not required.
5	Physical Dimension	JESD22 Method JB-100	Verify physical dimensions to the applicable device detail specification. Note: User(s) and Suppliers spec. Electrical Test not required.
6	Vibration	MIL-STD-202 Method 204	10~55Hz,1.5mm,2 hours in each 3mutually perpendicular directions,(total of 6 hours) Inductance:within±10% of initial value
7	Resistance to Soldering Heat	MIL-STD-202 Method 210	1. Max. 260±5°C,10±1s, 2 times 2.Solder Composition: Sn/3Ag/0.5Cu
8	Solderability	J-STD-002	245±5°C, 5±1sec, Solder: Sn/3.0Ag/0.5Cu
9	Electrical Characterization	User Spec.	Parametrically test per lot and sample size requirements, summary to show Min, Max, Mean and Standard deviation at room as well as Min and Max Operating temperatures.
10	Board Flex	AEC-Q200-005	2mm(min), Dwell:30±1 sec.
11	Terminal Strength	AEC-Q200-006	Force:≥2.94N, Dwell:5+1 sec, X, Y direct