

## Test accessories - EV-T2MBIE24-1ACDC-INFRA - 1410506

Please be informed that the data shown in this PDF Document is generated from our Online Catalog. Please find the complete data in the user's documentation. Our General Terms of Use for Downloads are valid (<http://phoenixcontact.com/download>)



Special Vehicle Inlet for charging station tests, CCS type 2, IEC 62196-3, 125 A / 850 V (DC), 24 V Locking actuator, Single wires, Length: 2 m

### Product Description

Special Vehicle Inlet for charging station tests, solely for laboratory tests, tests with charging stations (EVSE), and further analyses on the infrastructure side - not for installation in any type of vehicle, cannot be used outside of the laboratory area



### Key Commercial Data

Packing unit	1 pc
Weight per Piece (excluding packing)	4580.0 g
Custom tariff number	85366990
Country of origin	Germany

### Technical data

#### Dimensions

Conductor length	2.00 m
------------------	--------

#### General

Product type	Special Vehicle Inlet for charging station tests
Standards/regulations	IEC 62196-3
Charging standard	CCS type 2
Charging mode	Mode 2, 3, 4

#### Features

Charging power	106 kVA
Number of phases	1
Rated current for power contacts	125 A DC
	20 A AC
Rated voltage for power contacts	250 V AC

## Test accessories - EV-T2MBIE24-1ACDC-INFRA - 1410506

### Technical data

#### Features

	850 V DC
Rated current for signal contacts	2 A
Rated voltage for signal contacts	30 V AC
Type of signal transmission	Pulse width modulation
Temperature monitoring	2x Pt 1000
Number of power contacts	5 (L1, N, PE, DC+, DC-)
Number of signal contacts	2 (CP, PP)
Insertion force	< 100 N
Withdrawal force	< 100 N
Insertion/withdrawal cycles	> 10000
Ambient temperature (operation)	-30 °C ... 50 °C
Ambient temperature (storage/transport)	-40 °C ... 80 °C
Altitude difference for area of application	5000 m (above sea level)
Degree of protection	IP44 (plugged in)
	IP55 (in road position)

#### Locking actuator

Typical power supply at the motor	24 V
Possible power supply range at the motor	22 V ... 26 V
Typical motor current for locking	0.05 A
Max. reverse current of the motor	0.5 A
Max. dwell time with reverse current	1000 ms
Recommended adaptation time	600 ms
Maximum voltage for locking detection	30 V
Service life	> 10000 load cycles
Ambient temperature (operation)	-30 °C ... 50 °C
Length of cable	0.5 m

### Classifications

#### eCl@ss

eCl@ss 4.1	27260701
eCl@ss 5.1	27059110
eCl@ss 6.0	27059290
eCl@ss 8.0	27440590
eCl@ss 9.0	27144706

# Test accessories - EV-T2MBIE24-1ACDC-INFRA - 1410506

## Classifications

ETIM

ETIM 4.0	EC002498
ETIM 5.0	EC002498

## Drawings

Connection diagram

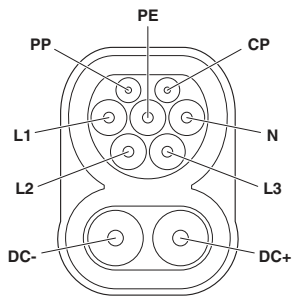

Pin assignment of Vehicle Inlet

Dimensional drawing

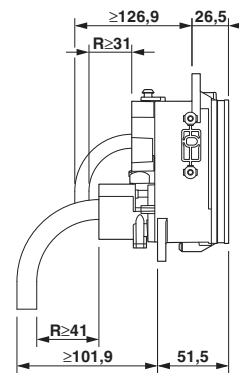

Dimensional drawing, side view

Dimensional drawing

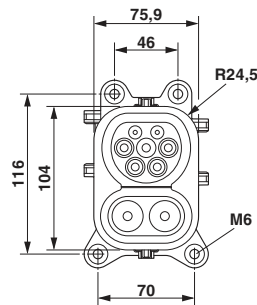

Dimensional drawing top view

## Test accessories - EV-T2MBIE24-1ACDC-INFRA - 1410506

Schematic diagram

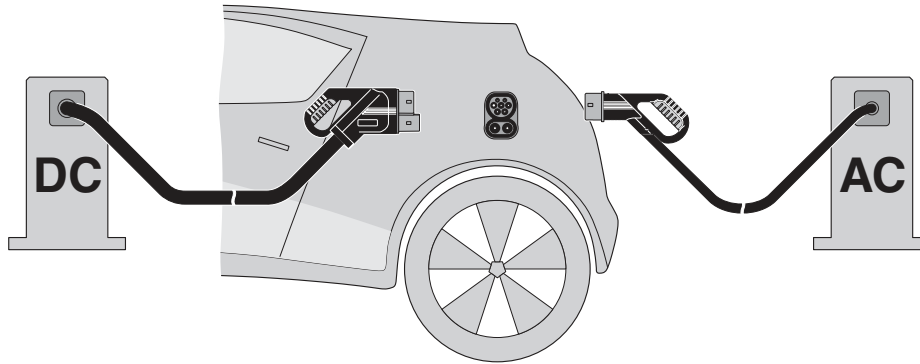

The Combined Charging System (CCS) principle - standard-compliant charging system for electric vehicles, which supports both conventional AC charging and fast DC charging. Both Vehicle Connectors fit into the CCS Vehicle Inlet.

# Test accessories - EV-T2MBIE24-1ACDC-INFRA - 1410506

Schematic diagram

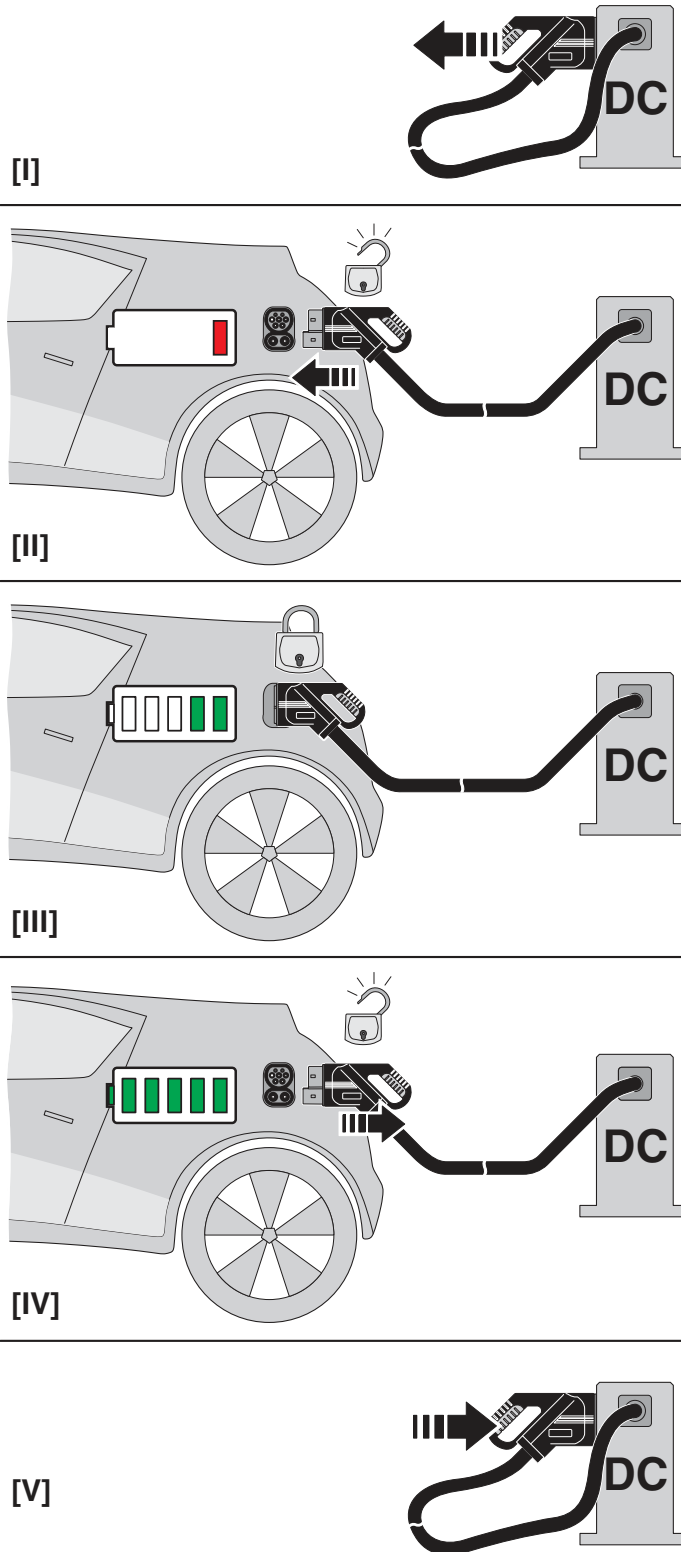

# Test accessories - EV-T2MBIE24-1ACDC-INFRA - 1410506

Schematic diagram

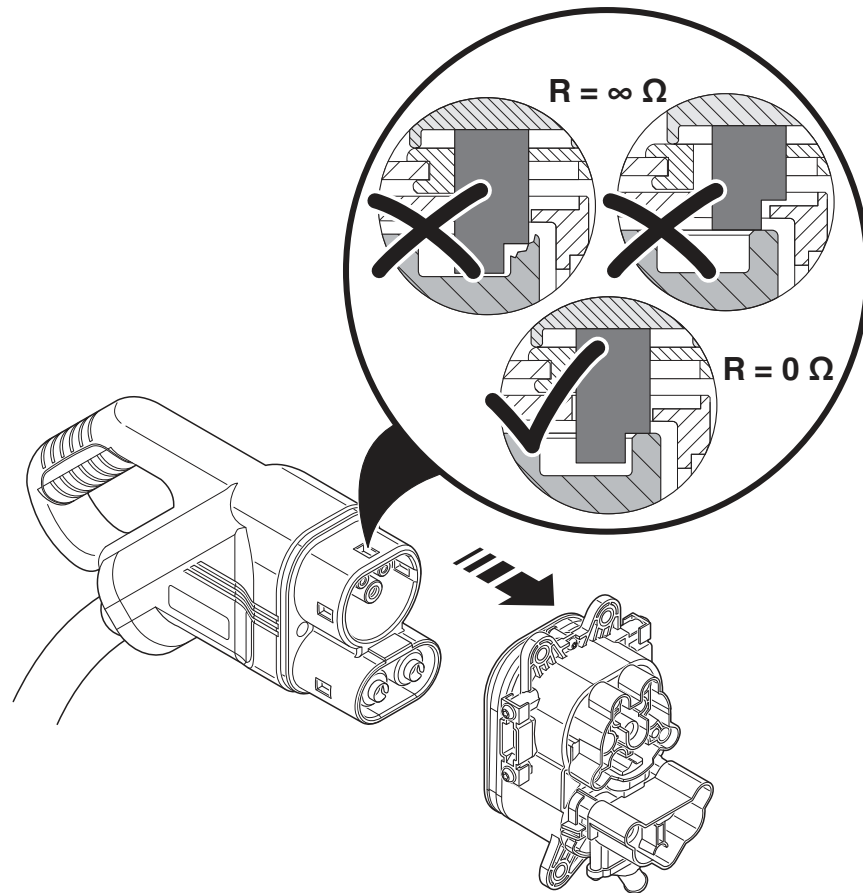

Detection for Vehicle Connector