

1. MAXIMUM PANEL THICKNESS = 6.35 [.25]
2. USE HAND TOOL 220022-2.
3. USE INSTRUCTION SHEET 408-9821.

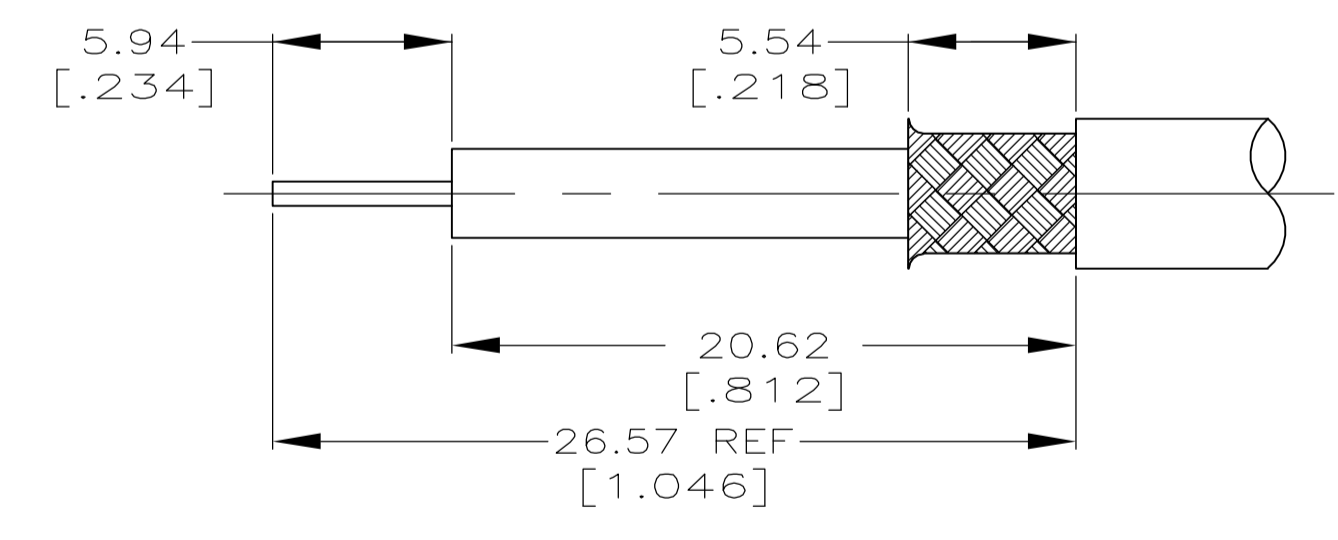
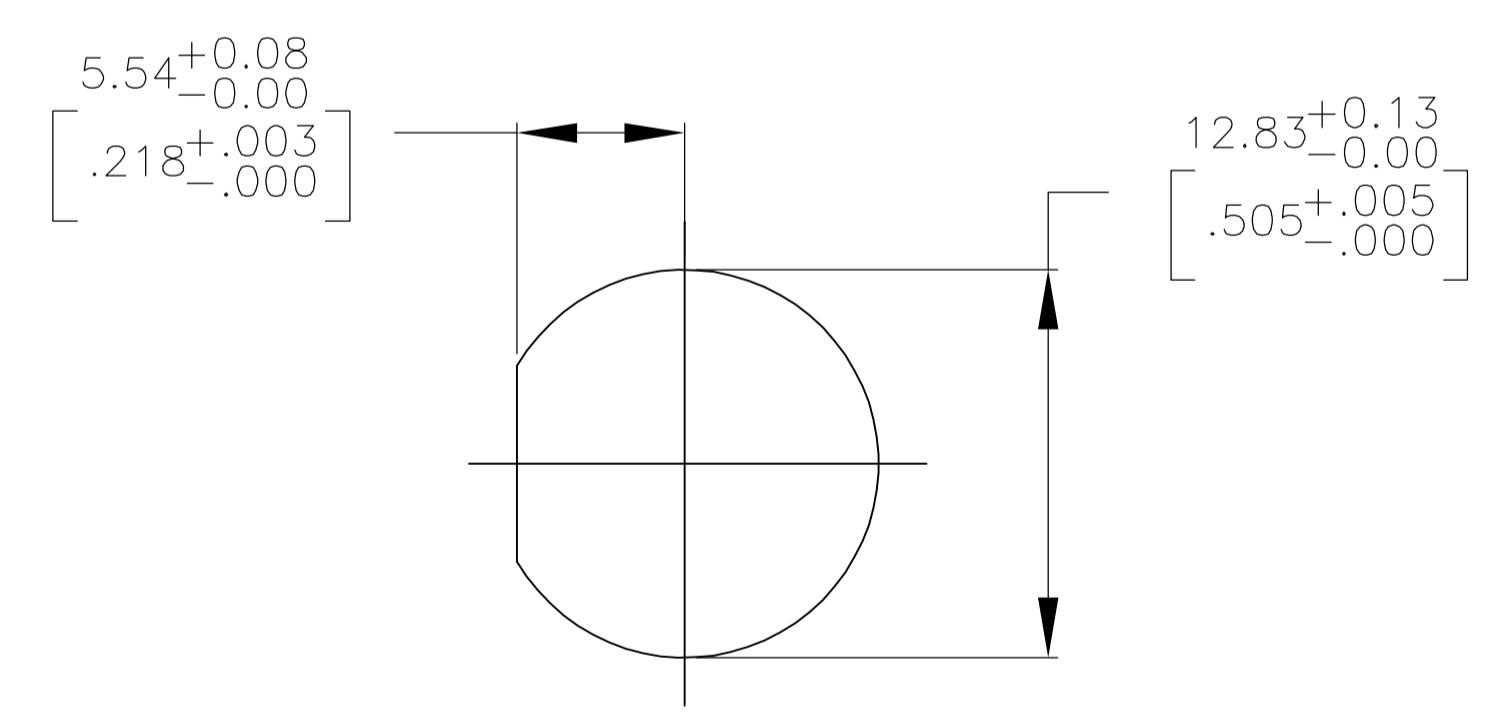
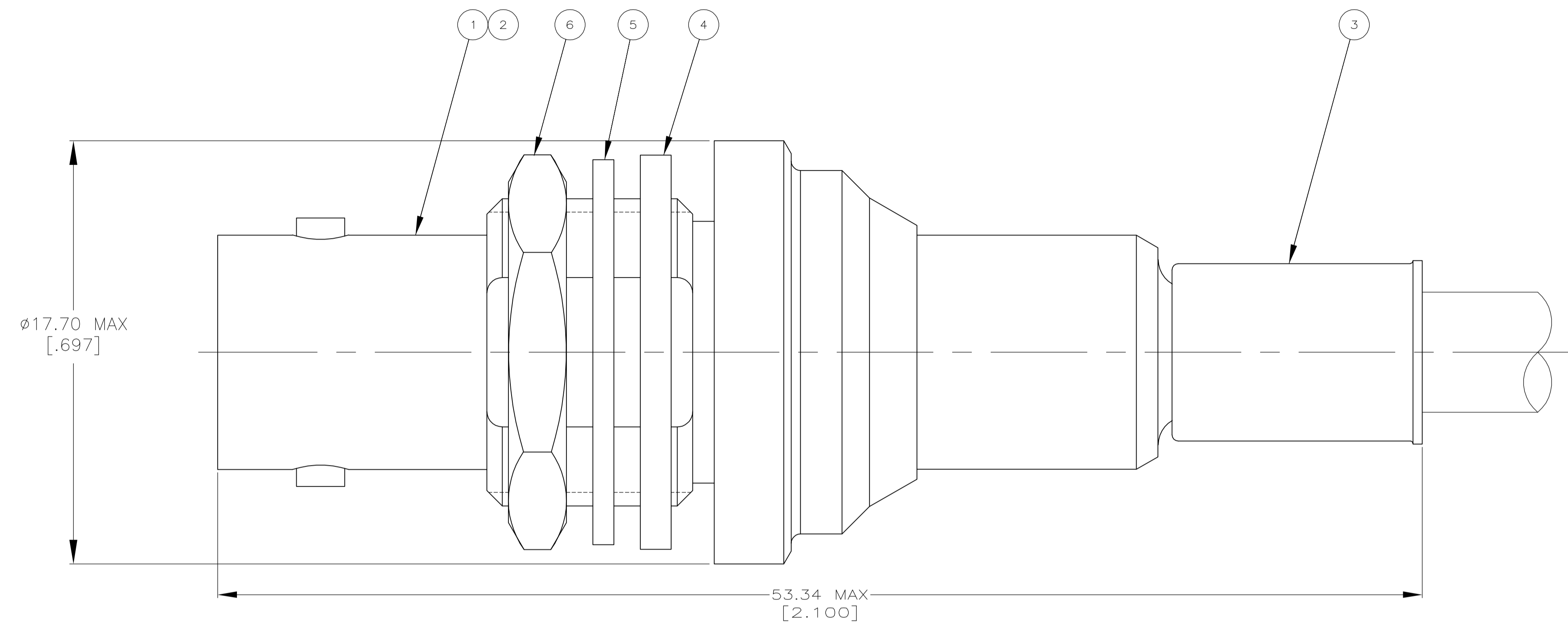

RG-59/U, 59A/U, 59B/U, 62/U, 62A/U, 62B/U	1-329631-2	1-329632-2	328633	9-50428-0	225057-2	225060-4	5225059-3
FOR USE WITH CABLE	⑥ JAM NUT QTY=1	⑤ LOCK WASHER QTY=1	④ GASKET QTY=1	③ FERRULE QTY=1	② CONTACT QTY=1	① JACK ASSEMBLY QTY=1	PART NUMBER

THIS DRAWING IS A CONTROLLED DOCUMENT.

DIMENSIONS: mm [INCHES]	TOLERANCES UNLESS OTHERWISE SPECIFIED:	DIN J. HAVENER 01MAR2005	 Tyco Electronics Corporation Harrisburg, Pa 17105-3608
0 PLC ± -	1 PLC ± -	01MAR2005	
2 PLC ± -	3 PLC ± 0.041 [0.16]	APVD J. LIPPERT 01MAR2005	NAME JACK, BULKHEAD, SHV
4 PLC ± -	ANGLES ± -	PRODUCT SPEC	APPLICATION SPEC
MATERIAL	FINISH	WEIGHT	RESTRICTED TO
		A1 00779	SCALE 8:1 SHEET 1 OF 1 REV 0

CUSTOMER DRAWING