

LOC	DIST	REVISIONS			
P	LTH	DESCRIPTION	DATE	DWN	APVD
GP	00	A	RELEASED FOR PRODUCTION	07MAR2016	TX SH

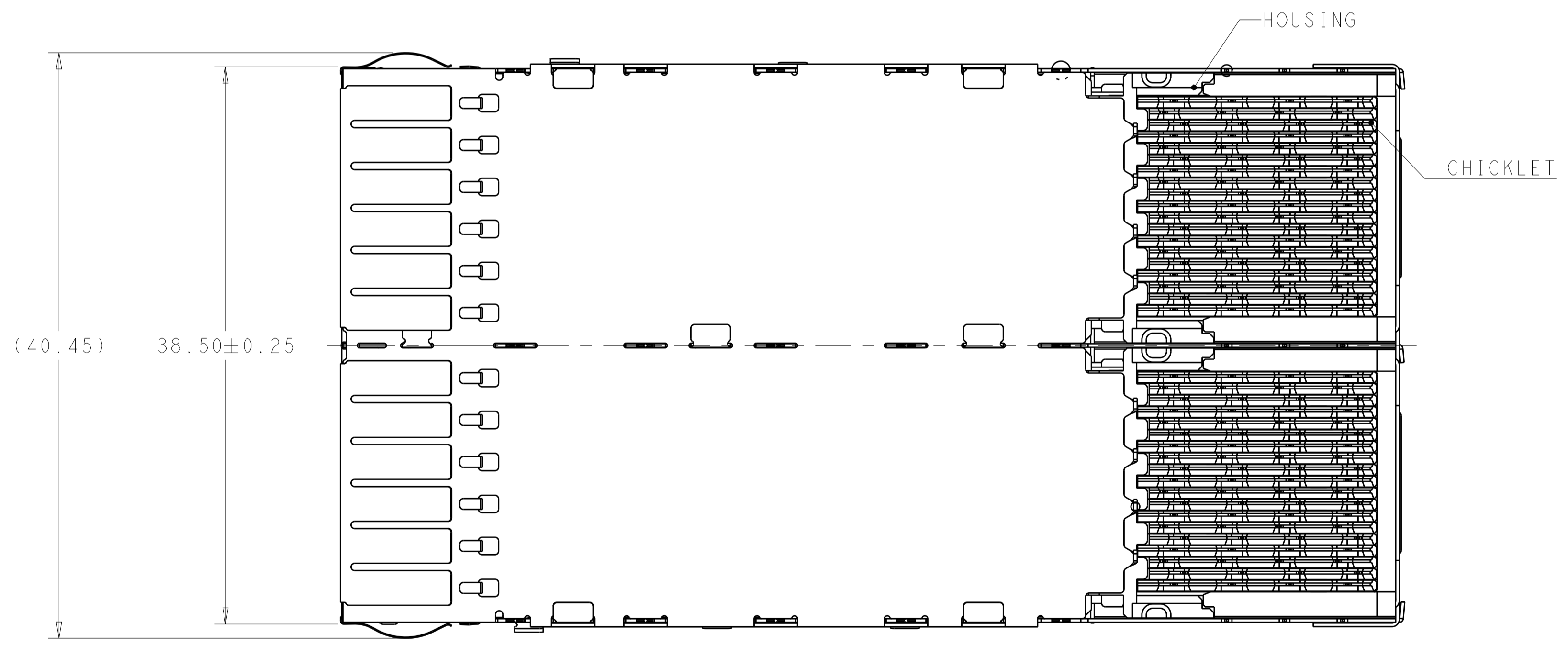
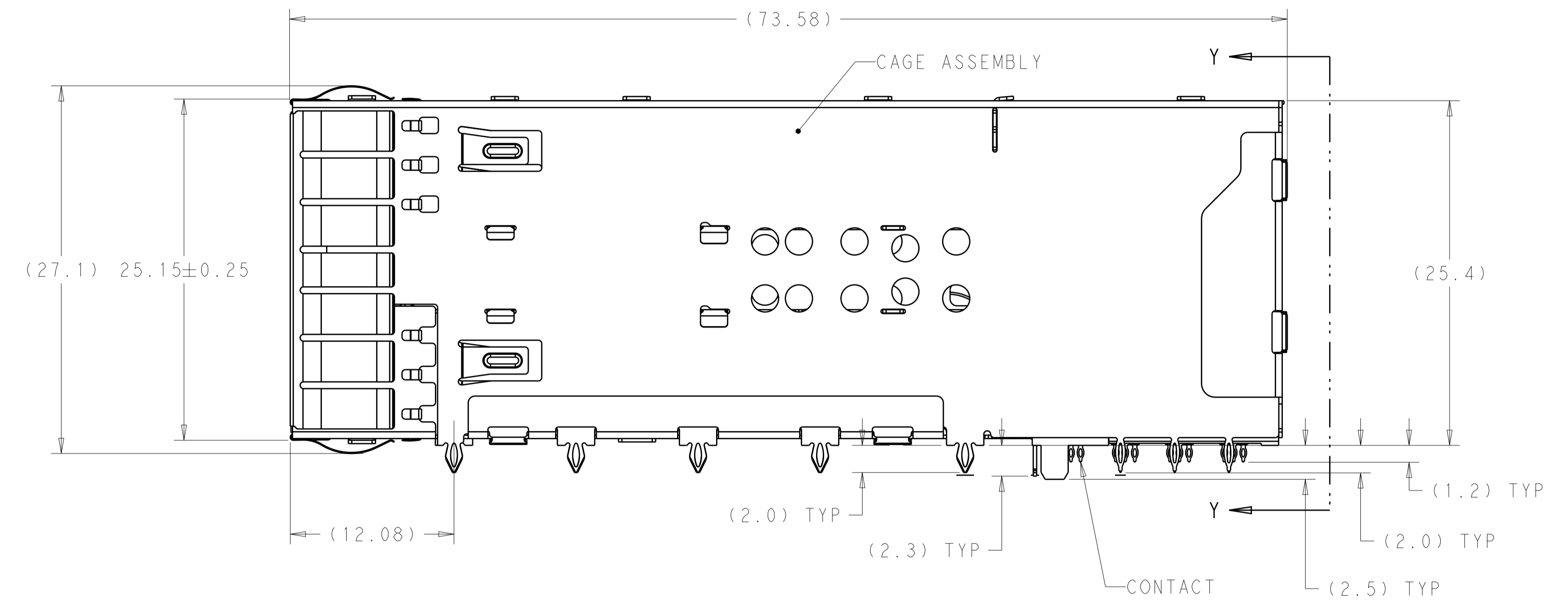
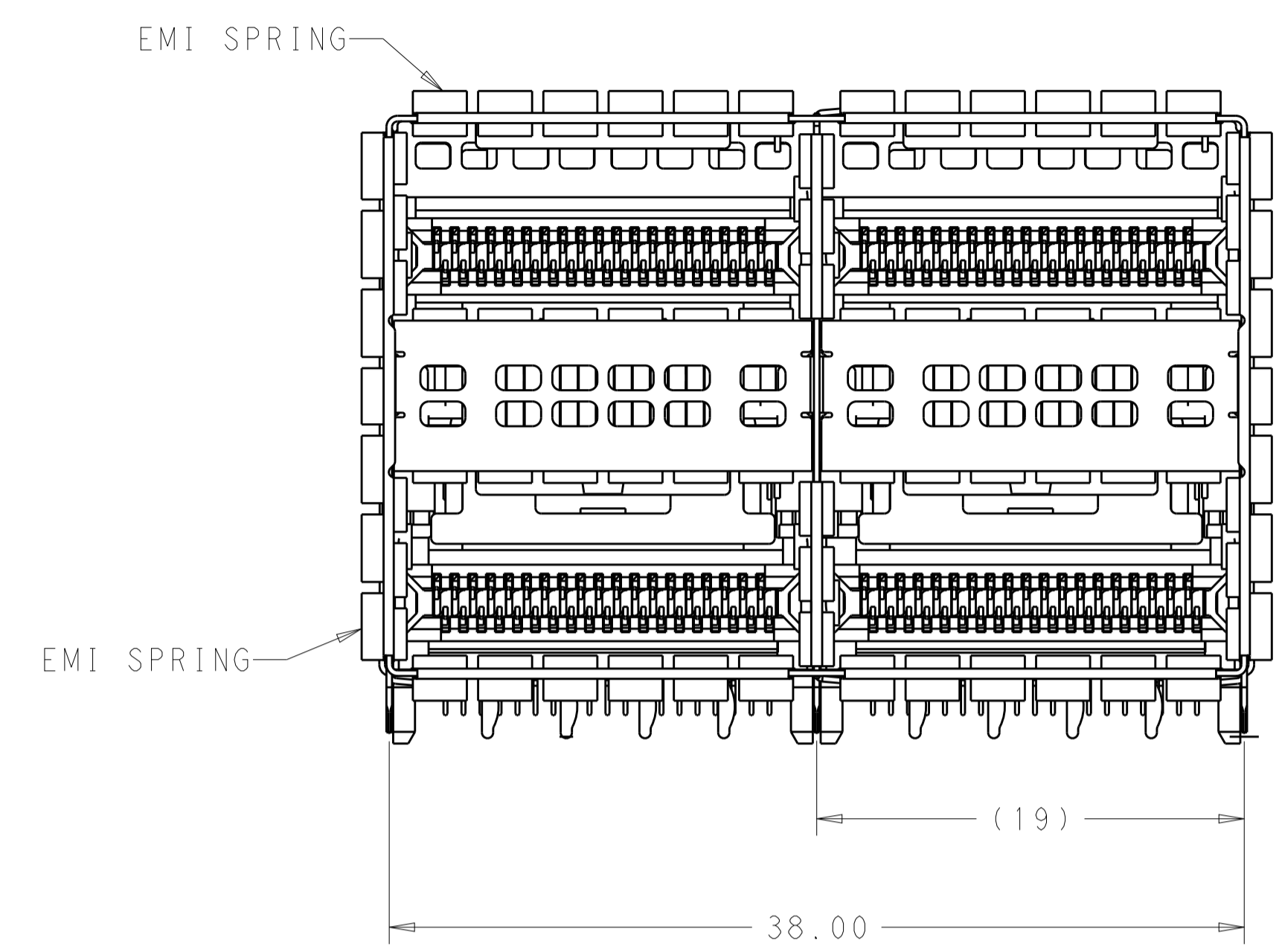

1. MATERIALS:
 CAGE ASSEMBLY- NICKEL SILVER ALLOY PER ASTM B 122.
 EMI SPRING- COPPER ALLOY, NICKEL PLATED.
 HOUSING- POLYESTER LCP WITH 94V-0.
 CHICKLET- POLYESTER LCP WITH 94V-0.
 CONTACT- COPPER ALLOY.
 LIGHTPIPE- POLYCARBONATE WITH 94V-0.

- ② CONTACT FINISH: 0.76µm GOLD ON MATING END, 1.25µm MATT TIN ON SOLDER TAIL, ALL OVER 1.27µm NICKEL.
 ③ DATUM AND BASIC DIMENSION ESTABLISHED BY CUSTOMER.
 4. MINIMUM PCB THICKNESS OF 1.57.
 ⑤ THE ENTIRE AREA OF THE CONNECTOR FOOTPRINT, INDICATED BY THE DASHED LINE, TO BE CONSIDERED THE KEEPOUT AREA FOR COMPONENTS.
 ⑥ CROSS-HATCHED AREAS REPRESENT ZONES ON THE PCB THAT COME IN CONTACT WITH OR BE IN CLOSE PROXIMITY TO THE PLASTIC HOUSING OR THE CONNECTOR CAGE. INDICATED AREAS TO BE CONSIDERED TRACE FREE.
 ⑦ PART NUMBER AND DATE CODE MADE IN APPROXIMATE AREA SHOWN.
 ⑧ THESE HOLES ARE OPTIONAL WHEN PINS ON BACK OF CAGE ARE REMOVED.
 ⑨ CONTACT FINISH: 0.08µm MINIMUM GOLD OVER 0.68µm PALLADIUM-NICKEL ON MATING END, 1.25µm MATT TIN ON SOLDER TAIL, ALL OVER 1.27µm NICKEL.
 ⑩ HATCHED AREA IS PLACEMENT ZONE FOR LED. LED SHOULD BE CENTERED WITHIN ZONE. RECOMMEND 0805 PACKAGE.

CONTACT FINISH	DESCRIPTION	PART NUMBER
⑨	LEFT INDICATOR DOWN	2227667-6
⑨	LEFT INDICATOR UP	2227667-5
⑨	NO LIGHTPIPE	2227667-4
②	LEFT INDICATOR DOWN	2227667-3
②	LEFT INDICATOR UP	2227667-2
②	NO LIGHTPIPE	2227667-1

THIS DRAWING IS A CONTROLLED DOCUMENT. DWN: M. SHIRK 18JAN2013
 CHK: D. SZCZESNY 18JAN2013
 APVD: -

DIMENSIONS: mm
 TOLERANCES UNLESS OTHERWISE SPECIFIED:
 0 PLC ±
 1 PLC ±0.25
 2 PLC ±0.15
 3 PLC ±
 4 PLC ±
 ANGLES ° ±
 FINISH

MATERIAL: SEE NOTE 1
 SEE NOTE 2

PRODUCT SPEC: 108-60102
 APPLICATION SPEC: 114-60015
 WEIGHT: -
 CUSTOMER DRAWING

NAME: CAGE AND CONNECTOR ASSEMBLY, WITH EMI SPRING, THRU BEZEL, 2X2, ZQSFP+ STACKED
 SIZE: A100779
 CAGE CODE: -
 DRAWING NO: C=2227667
 RESTRICTED TO: -

SCALE: 4:1 SHEET 1 OF 4 REV A

LOC		DIST		REVISIONS			
P	LTN	DESCRIPTION	DATE	DMN	APVD		
-	-	SEE SHEET 1	-	-	-		

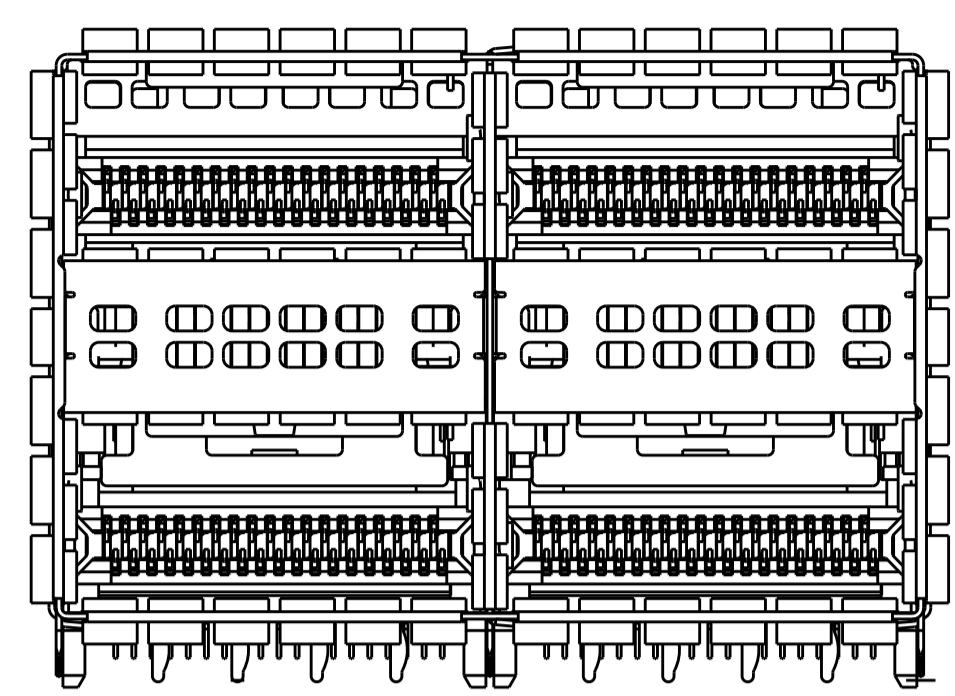

2227667-1 / 2227667-4
 NO LIGHTPIPE IN ASSEMBLY
 SCALE 3:1

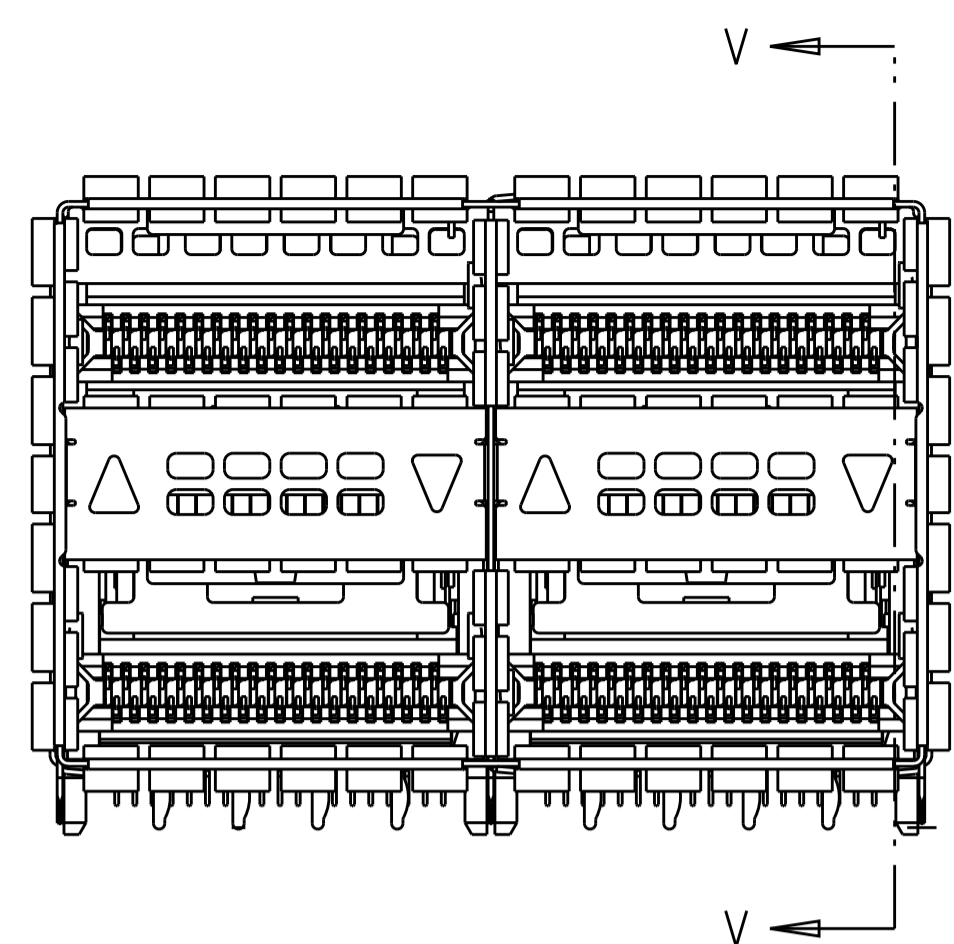

2227667-2 / 2227667-5
 LEFT LIGHTPIPE INDICATOR
 POINTING TO UPPER PORT
 SCALE 3:1

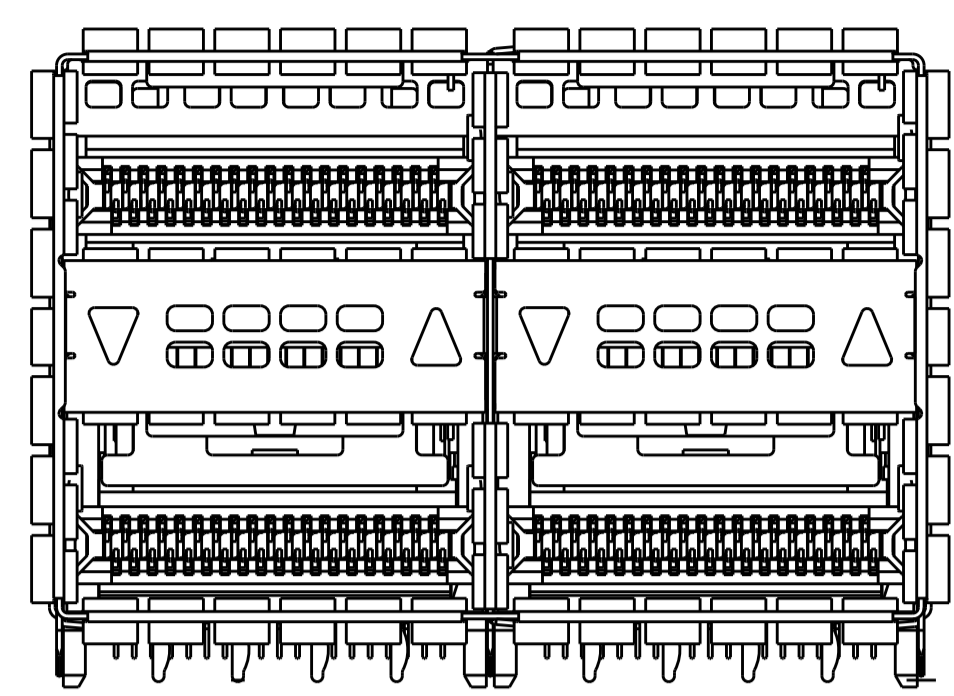

2227667-3 / 2227667-6
 LEFT LIGHTPIPE INDICATOR
 POINTING TO LOWER PORT
 SCALE 3:1

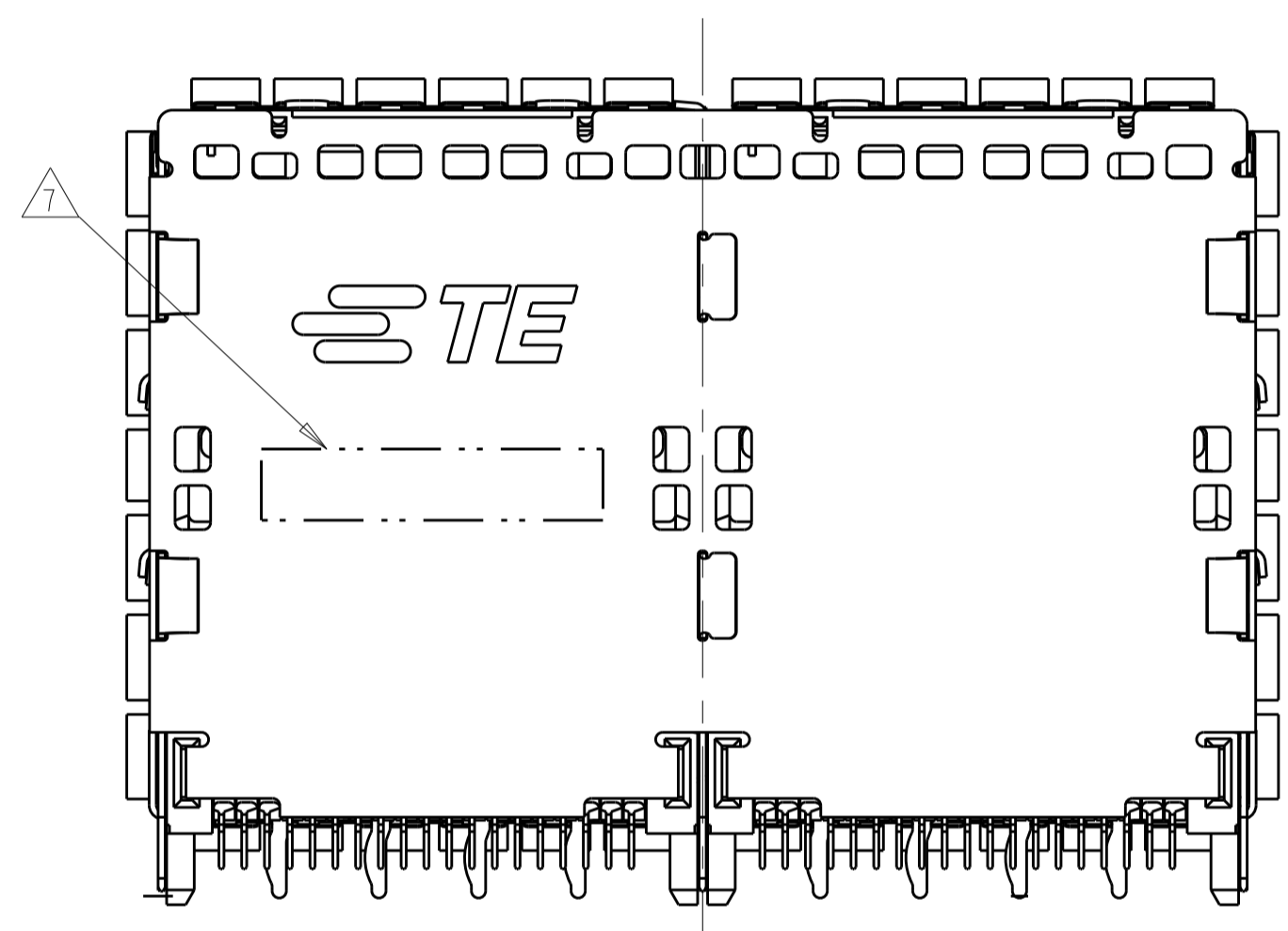

VIEW Y-Y

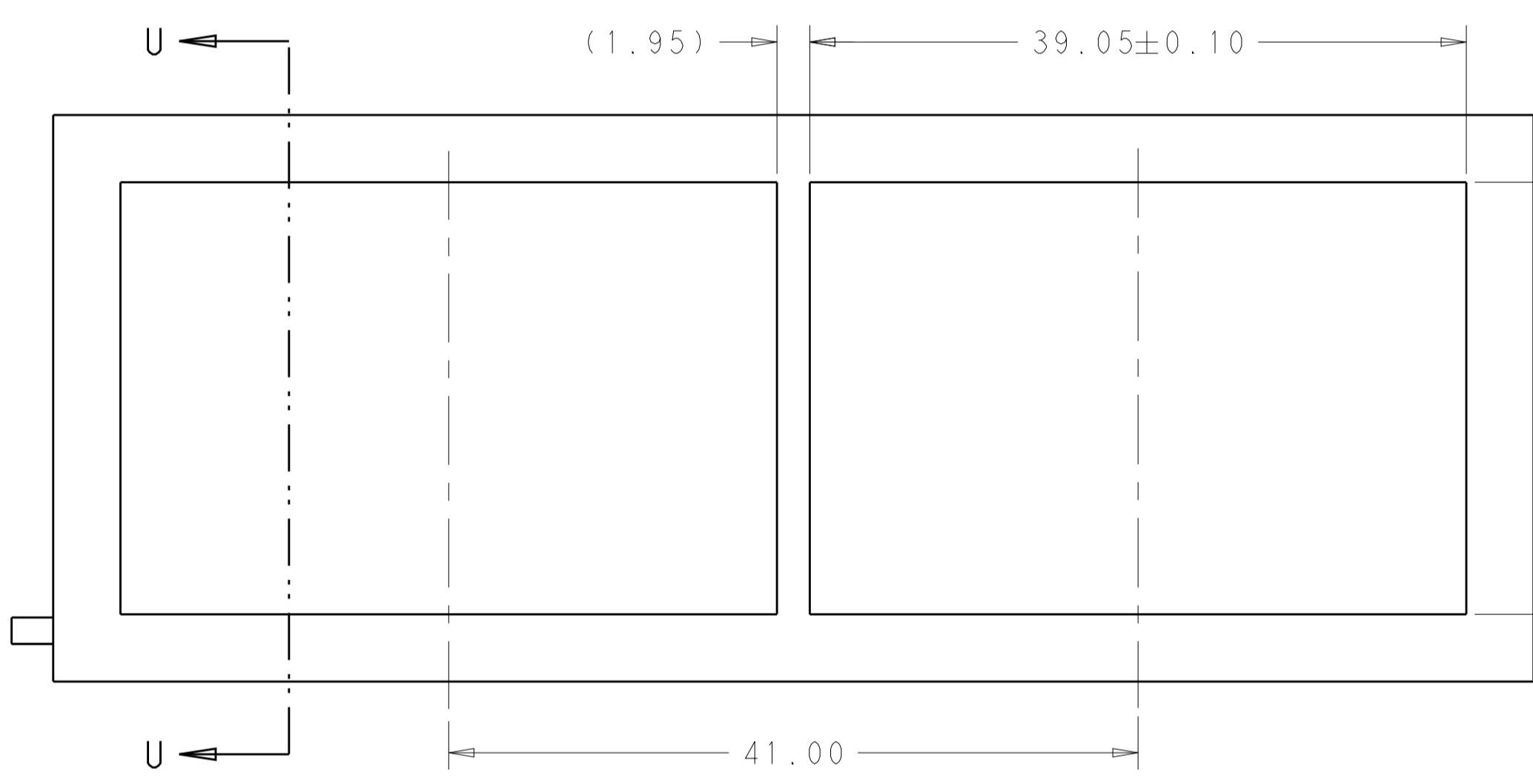

RECOMMENDED PANEL CUTOUT
 AND PC BOARD, PANEL POSITION
 SCALE 3:1

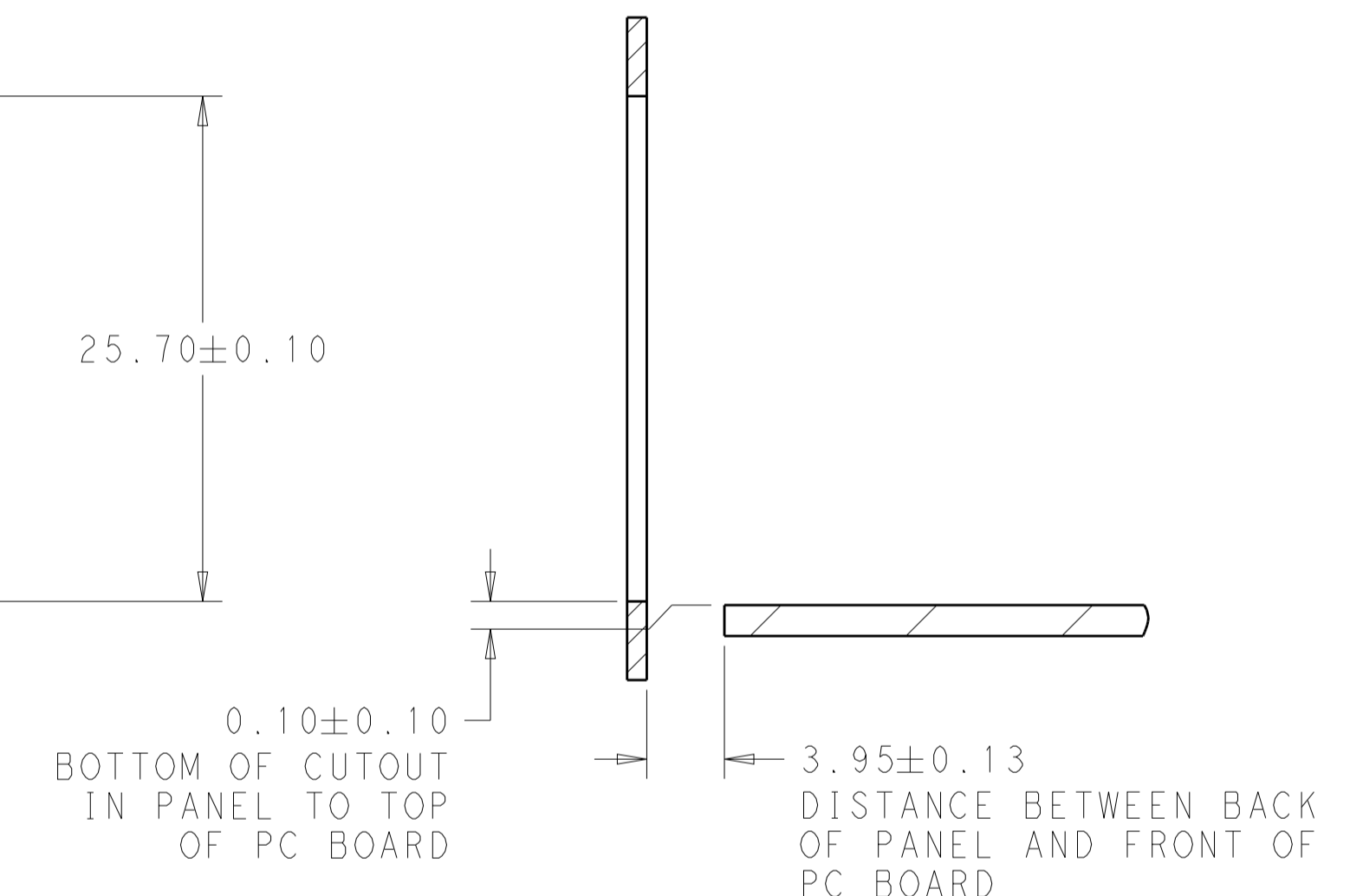

SECTION U-U

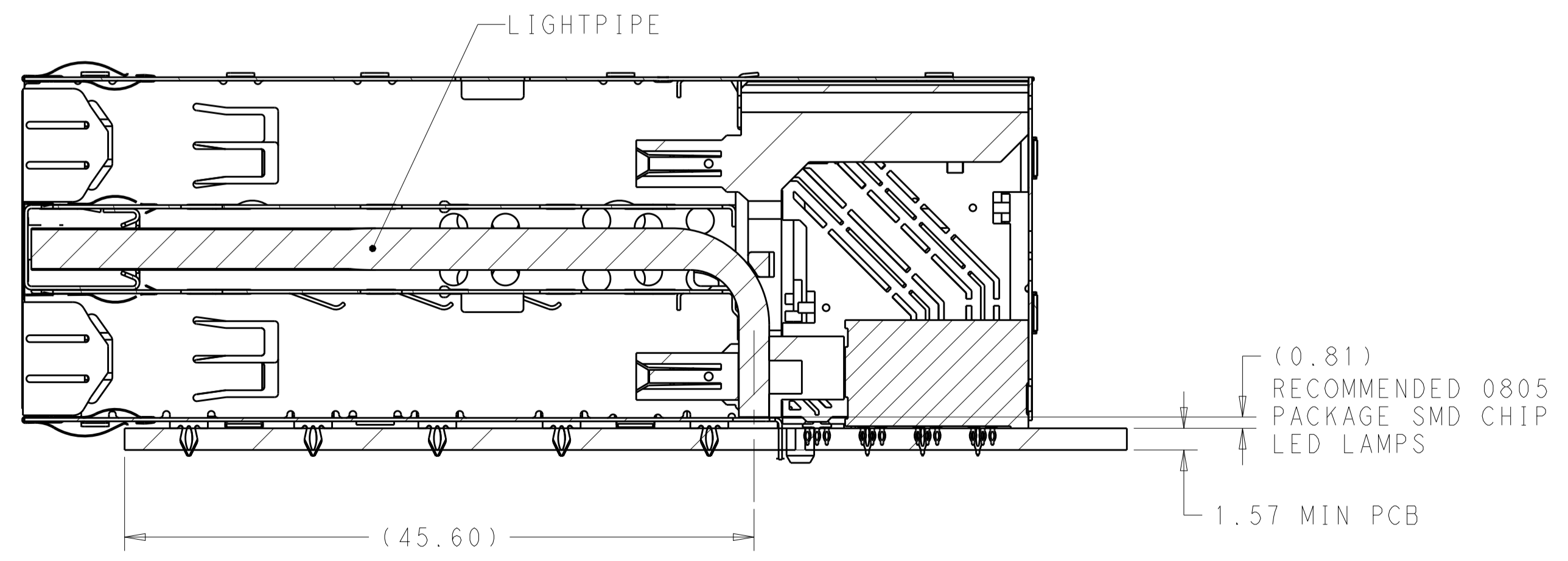

SECTION V-V
 SCALE 3:1

THIS DRAWING IS A CONTROLLED DOCUMENT.		DMN M. SHIRK 18JAN2013	TE Connectivity	
DIMENSIONS:		CHK D. SZCZESNY 18JAN2013	NAME CAGE AND CONNECTOR ASSEMBLY, WITH EMI SPRING, THRU BEZEL, 2X2, ZQSFP+ STACKED	
mm	TOLERANCES UNLESS OTHERWISE SPECIFIED:	APVD	PRODUCT SPEC 108-60102	RESTRICTED TO
	0 PLC ± 1 PLC ±0.25 2 PLC ±0.15 3 PLC ± 4 PLC ±	APPLICATION SPEC 114-60015	SIZE A100779	DRAWING NO C=2227667
MATERIAL	FINISH	WEIGHT	CUSTOMER DRAWING	SCALE 4:1 SHEET 2 OF 4 REV A
SEE NOTE 1	SEE NOTE 2			

REVISONS		DATE	OWN	APVD
P. LTH	DESCRIPTION			
-	SEE SHEET 1	-	-	-

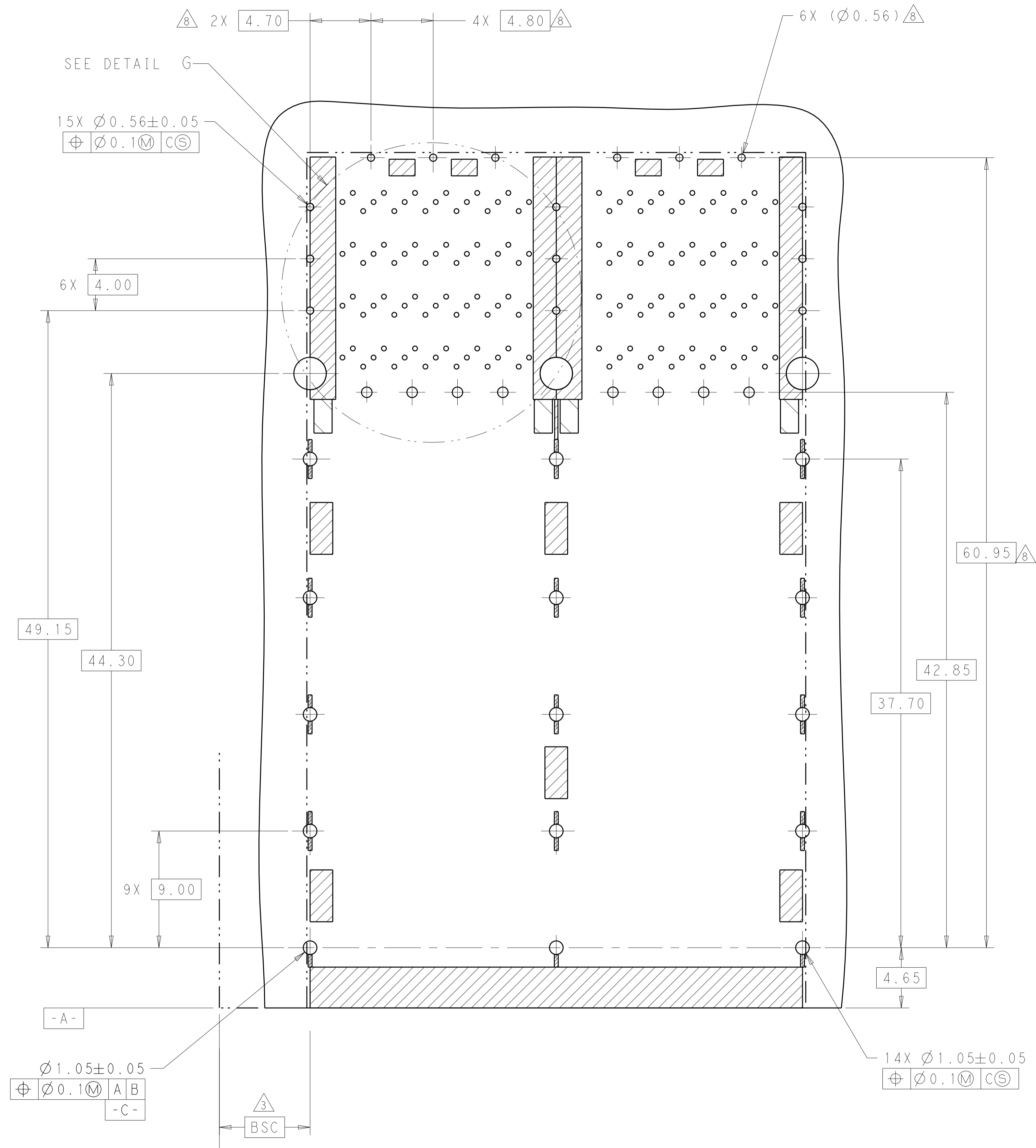

RECOMMENDED PCB BOARD LAYOUT
 COMPONENT SIDE OF BOARD
 (PCB TOLERANCE ±0.05)
 SCALE 5:1

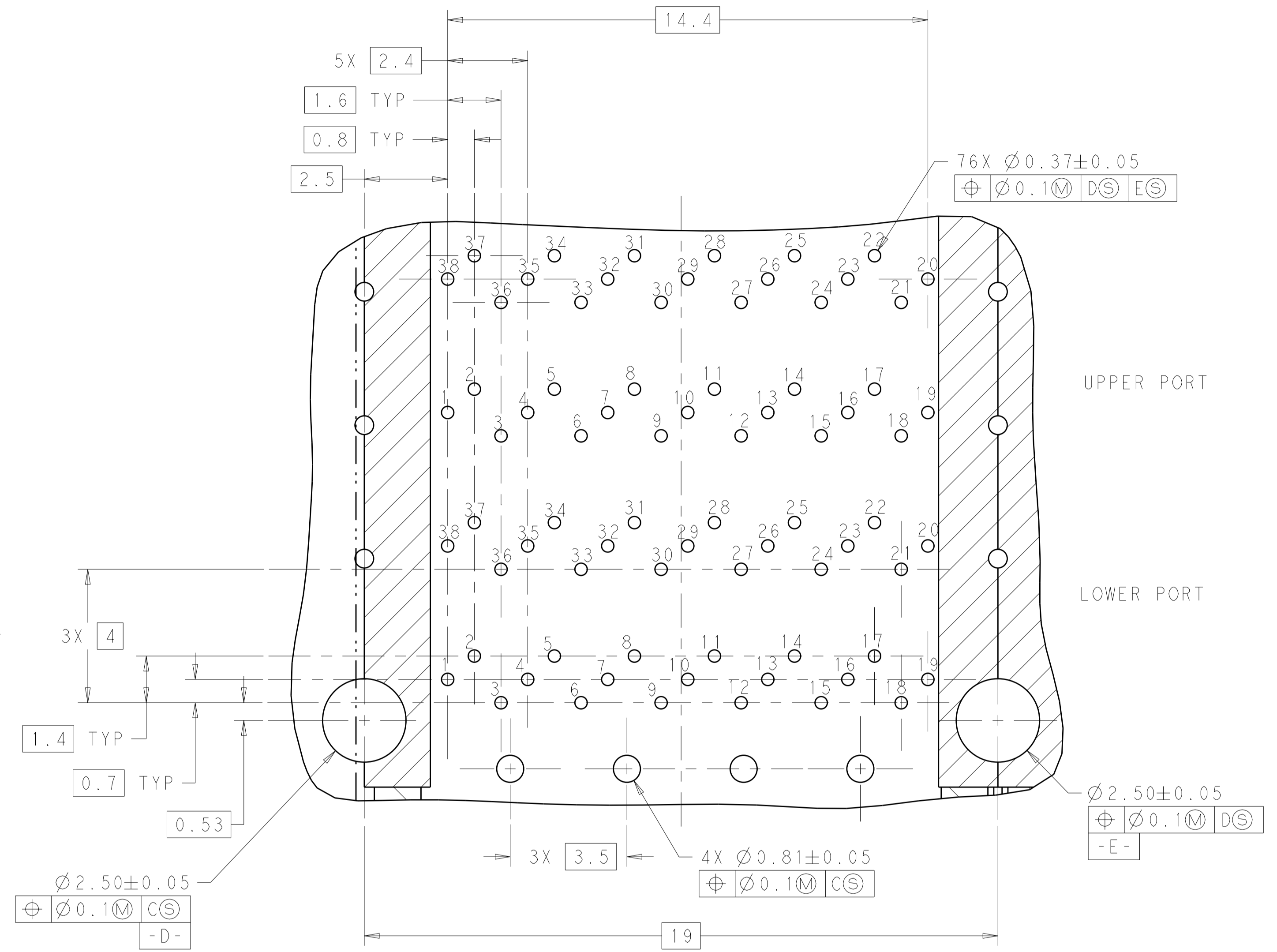

DETAIL G
 SCALE 10:1

THIS DRAWING IS A CONTROLLED DOCUMENT.		OWN: M. SHIRK 18JAN2013	TE Connectivity
DIMENSIONS: mm		CHK: D. SZCZESNY 18JAN2013	
TOLERANCES UNLESS OTHERWISE SPECIFIED:		APVD: -	NAME: CAGE AND CONNECTOR ASSEMBLY, WITH EMI SPRING, THRU BEZEL, 2X2, ZQSFP+ STACKED
0 PLC ±0.25	1 PLC ±0.15	PRODUCT SPEC: 108-60102	SIZE: 114-60015
2 PLC ±0.15	3 PLC ±0.15	APPLICATION SPEC: 114-60015	WEIGHT: -
4 PLC ±0.15	ANGLES ±0.15	FINISH: -	CUSTOMER DRAWING
MATERIAL: -	FINISH: -	SEE NOTE 1	SEE NOTE 2
SEE NOTE 1		SEE NOTE 2	
SCALE 4:1		SHEET 3 OF 4	
REV A		REV A	

LOC	DIST	REV	DATE	BY	APPD
		1			

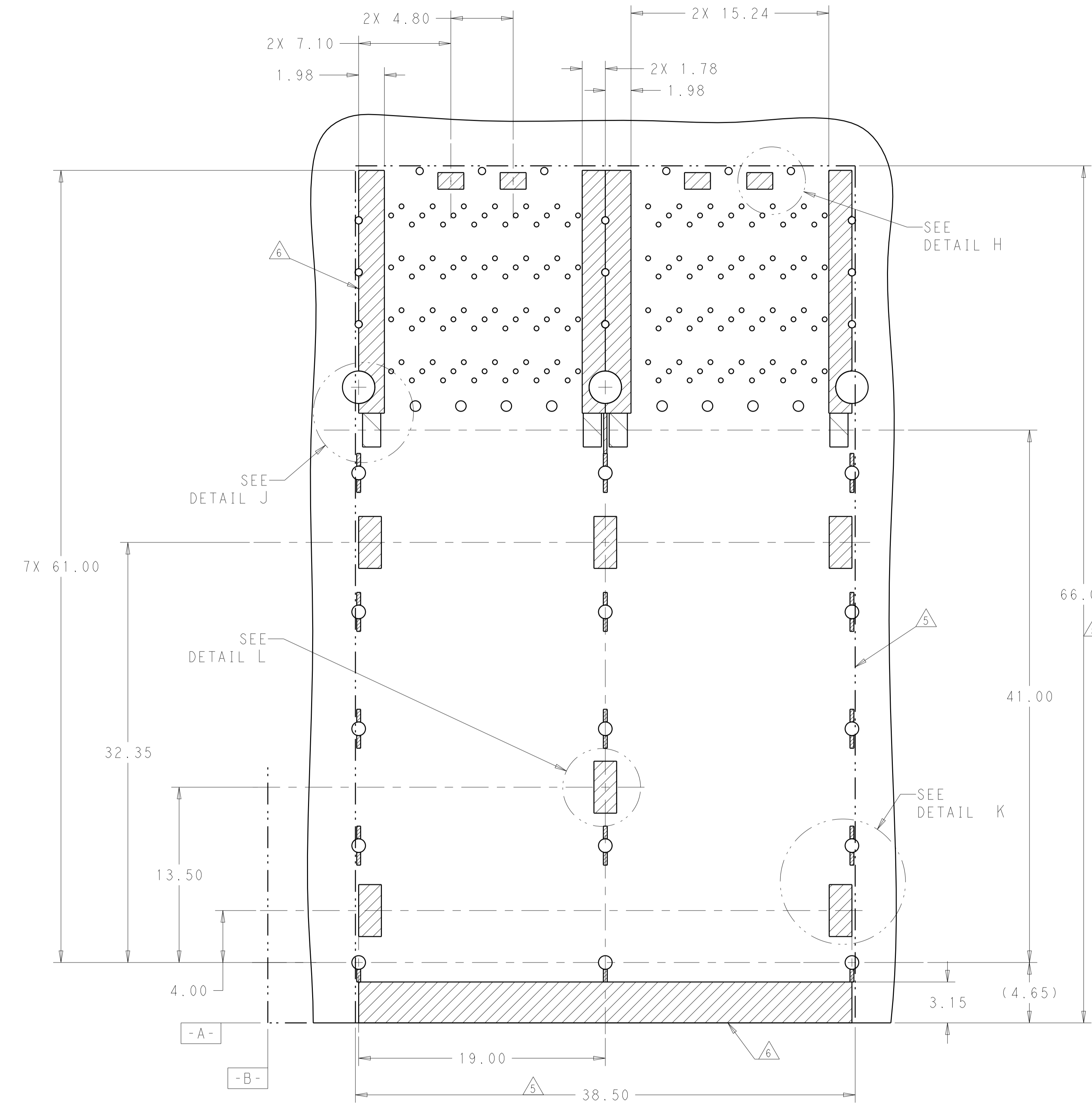

KEEP-OUT AREAS
 COMPONENT SIDE OF BOARD
 SCALE 5:1

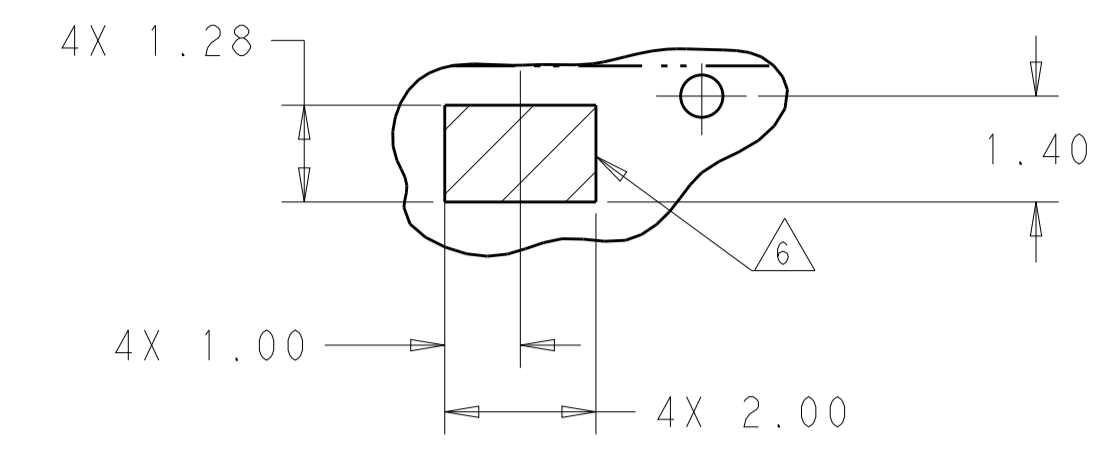

DETAIL H
 SCALE 10:1

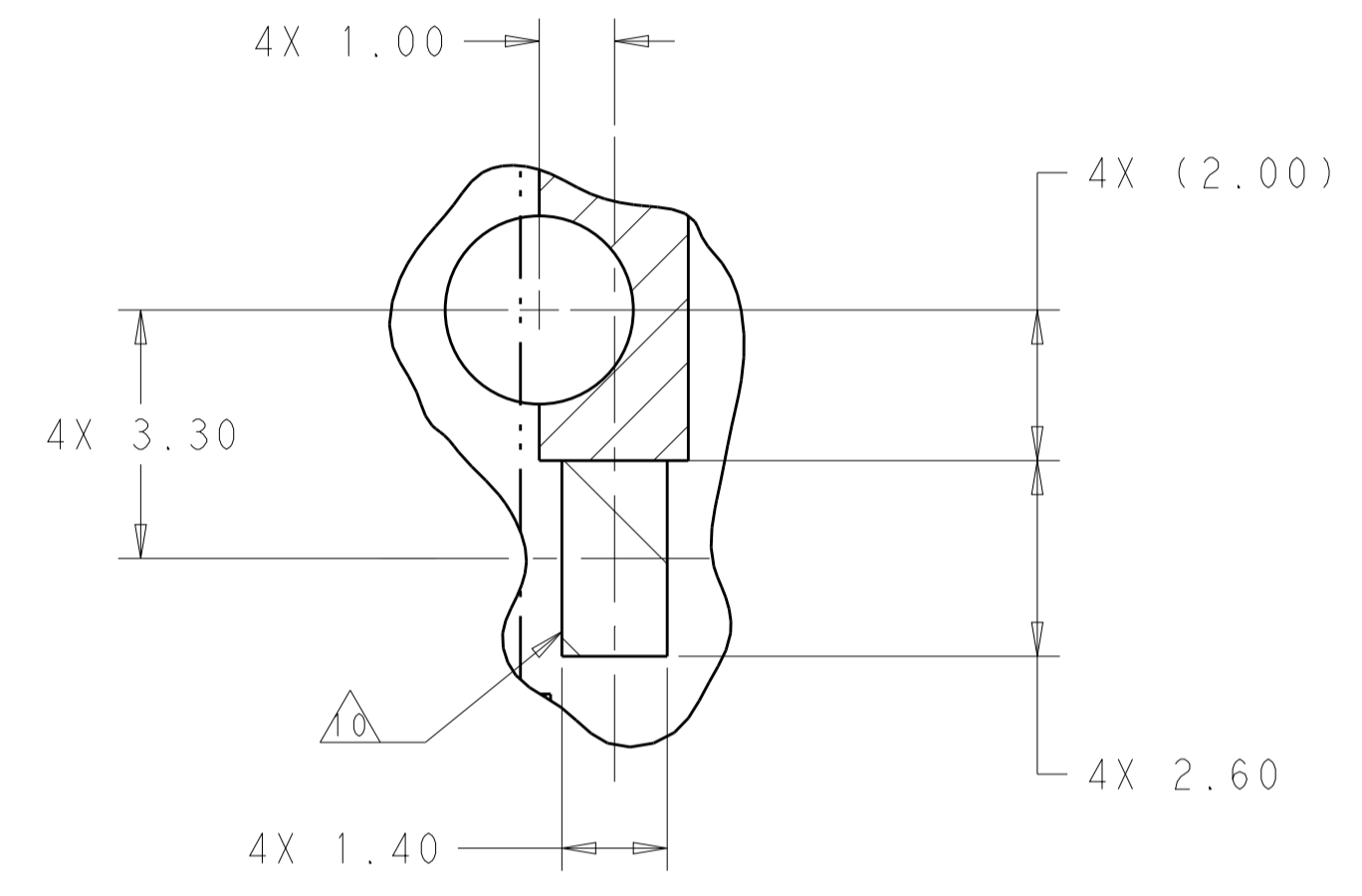

DETAIL J
 SCALE 10:1

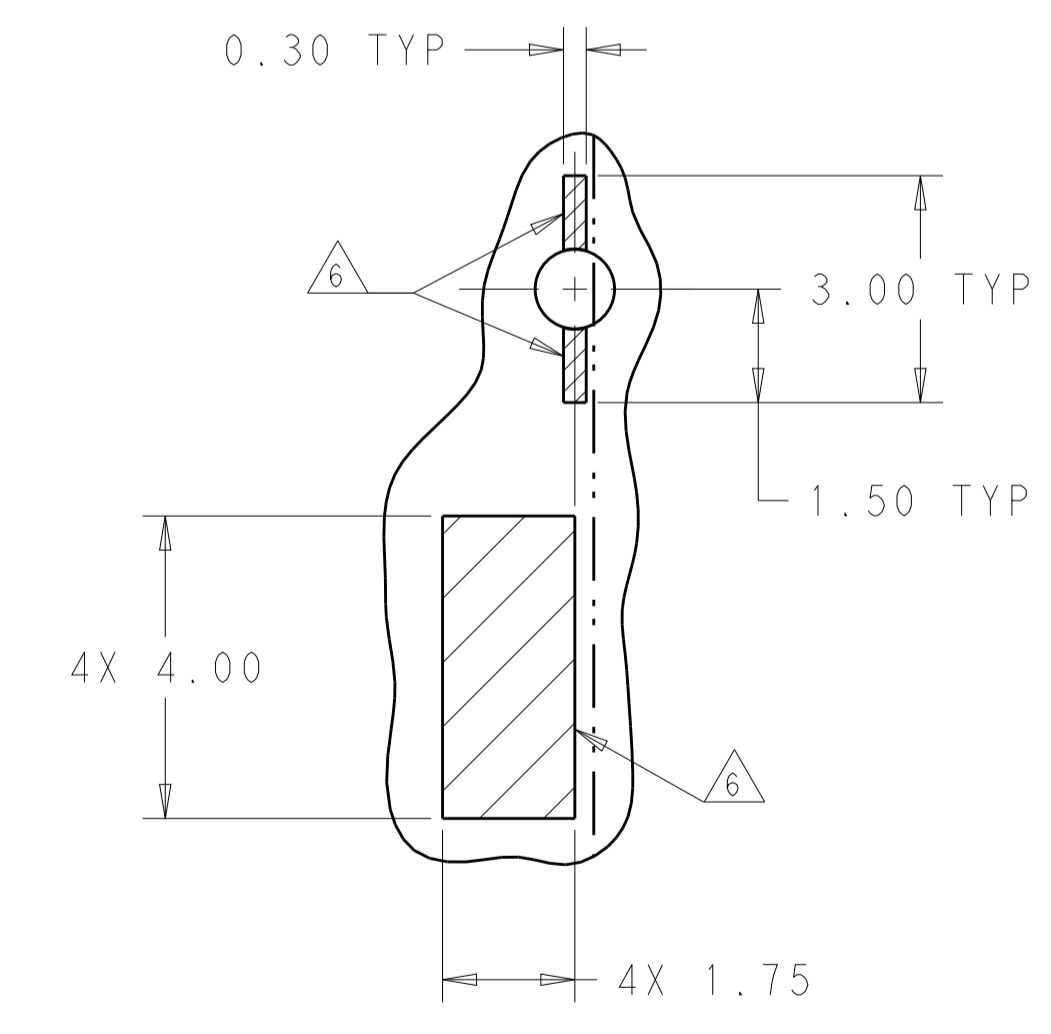

DETAIL K
 SCALE 10:1

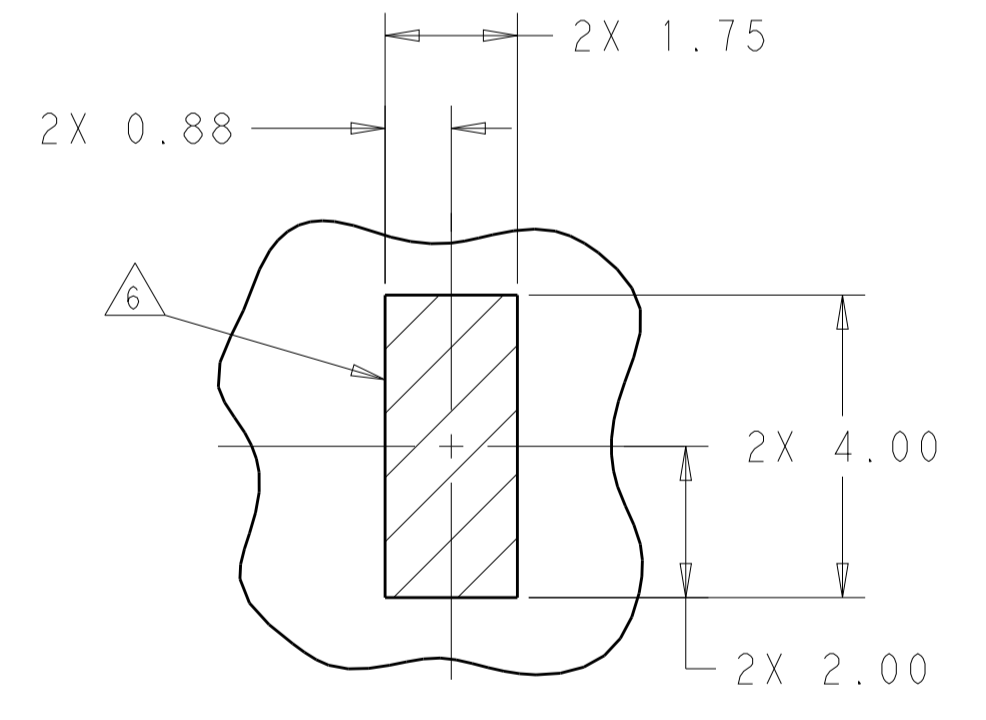

DETAIL L
 SCALE 10:1

THIS DRAWING IS A CONTROLLED DOCUMENT.		OWN: M. SHIRK 18JAN2013	TE Connectivity
DIMENSIONS: mm		CHK: D. SZCZESNY 18JAN2013	
TOLERANCES UNLESS OTHERWISE SPECIFIED:		APVD: -	NAME: CAGE AND CONNECTOR ASSEMBLY, WITH EMI SPRING, THRU BEZEL, 2X2, ZQSP+ STACKED
0 PLC ±0.25	1 PLC ±0.15	PRODUCT SPEC: 108-60102	RESTRICTED TO: -
2 PLC ±0.15	3 PLC ±0.15	APPLICATION SPEC: 114-60015	SIZE: A100779
4 PLC ±0.15	ANGLES ±0.15	WEIGHT: -	CAGE CODE: 2227667
MATERIAL: -	FINISH: -	CUSTOMER DRAWING	SCALE: 4:1 SHEET: 4 OF 4 REV: A