

SELECTED DETAIL

SCALE 5:1

BILL OF MATERIALS

NO.	QTY	SUPPLIER	DESCRIPTION	PART No.	SEE NOTE
1	1	NO PREFERRED SUPPLIER	2 CORE CABLE	99036-0045	3, 4, 6
2	1	MOLEX	MOULDED ON GROMMET	99038-0021	3
3	1	MOLEX	UPPER SHELL	91200-0004	2
	1		LOWER SHELL	91200-0003	
4	1	MOLEX	MOBILE PHONE CONTACT UNIT	91181-5002	1, 2
5	2	NO PREFERRED SUPPLIER	SELF TAPPING SCREWS	90848-0021	4
6	1	MOLEX	CABLE TIE WRAP	90848-0093	

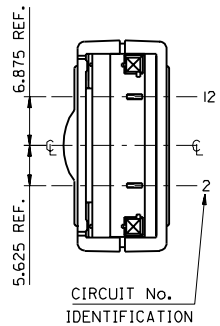
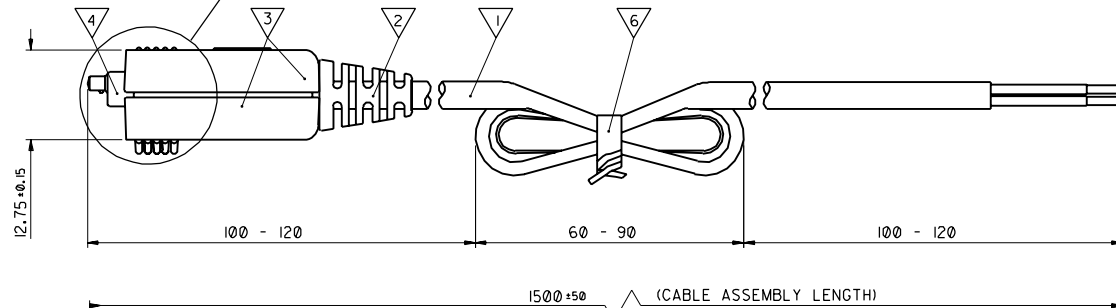

CIRCUIT No. IDENTIFICATION

NOTES:

- MATES WITH 91180 SERIES HANDSET CONNECTOR.
- SEE PRODUCT SPECIFICATION PS-91181-001.
- ONLY AVAILABLE FROM MOLEX AS PART OF A CABLE ASSEMBLY.
- SUPPLIER OR CUSTOMER APPROVED EQUIVALENT.
- PACKAGING : 150 PER CARTON.
- MAXIMUM DIAMETER OF CONDUCTORS AFTER STRIPPING & TINNING TO BE 1.1mm.

CABLE SPECIFICATION : 2 CORE CABLE

1. CABLE TYPE : FLAT SPIRAL CABLE RIBBON YES NO OTHER

NO. OF CONDUCTORS 2

2. CABLE REQUIREMENTS : N/A

3. CONDUCTOR SPECIFICATIONS :

CONDUCTOR :	CONDUCTOR NO.	
	1	2
- MATERIAL	TINNED Cu	TINNED Cu
- A.W.G.	22	22
- STRANDING QTY/GUAGE	7/30	7/30
- TENSILE STRENGTH	N/A	N/A
INSULATION :		
- MATERIAL	PVC	PVC
- MIN. WALL THICKNESS	0.22	
- COLOUR	RED	BLACK
- OUTSIDE DIAMETER	1.2 ± 0.05	
DIRECTION OF LAY	S	
LENGTH OF LAY	40 ± 10	
U.L. RATING	N/A	

4. FILLER : ENOUGH TO MAKE THE ASSEMBLY ROUND

5. SEPARATOR : N/A

6. SHIELD : FOIL TYPE N/A, FOIL FACING N/A

7. DRAIN WIRE : GAUGE N/A, STRANDING N/A, REQUIREMENT N/A

8. SPIRAL/BRAID : GAUGE N/A, COPPER TYPE N/A, COVERAGE N/A

9. CABLE JACKET : TYPE PVC, FINAL DIAMETER 3.80 ± 0.15, NOM. THICKNESS 0.70, COLOUR BLACK, FINISH MATT, U.L. RATING N/A, HARDNESS N/A, STRIPABILITY N/A, MARKINGS NONE

10. PACKAGING : PACKAGING SEE PACKAGING SPECIFICATION ESTABLISHED BY LOCAL PURCHASING AND MANUFACTURING DEPARTMENTS.

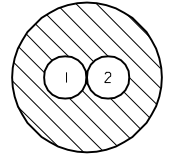

SCALE 10:1

WIRING DIAGRAM : 2 CORE CABLE

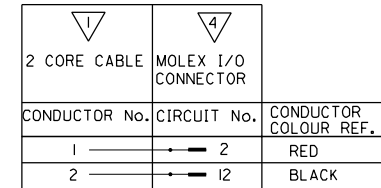

CORRECT CONN. VIEW EC NO. E1999-0630 DRWN: D. RYAN 99/06/24 CHK: / / / / APPR: / / / / REV A8	QUALITY SYMBOLS	GENERAL TOLERANCES: (UNLESS SPECIFIED)	SCALE N/A	DESIGN UNITS <input checked="" type="checkbox"/> mm <input type="checkbox"/> INCH	DIMENSIONS: mm <input type="checkbox"/> INCH <input type="checkbox"/> mm ONLY	SHT	REV	
	MAJOR	4 PLACES ±0. mm ±.	DRAWN BY & DATE D. RYAN 98/04/17	THIRD ANGLE PROJECTION	INCH			
	CRITICAL	3 PLACES ±0. mm ±.	CHECKED BY & DATE JJOCONNÉ 98/04/17					
	SPC	2 PLACES ±0.05 mm ±.	APPROVED BY & DATE MWILHITE 98/04/17					
		1 PLACE ±0.10 mm ±.	ANGULAR: ± 1/2°	CAD FILENAME S9260124.DGN	MATERIAL NO. 92601-0024	DRAWING NO. SD-92601-032	SHEET NO. 1 OF 1	
DRAFT WHERE APPLICABLE MUST REMAIN WITHIN DIMENSIONS			THIS DRAWING CONTAINS INFORMATION THAT IS PROPRIETARY TO MOLEX INCORPORATED AND SHOULD NOT BE USED WITHOUT WRITTEN PERMISSION.				SIZE C	

PART NO. 92601-0024
REV. SD-92601-032