

©1963 BY AMP INCORPORATED. ALL RIGHTS RESERVED. AMP PRODUCTS COVERED BY PATENTS AND/OR PATENTS PENDING.

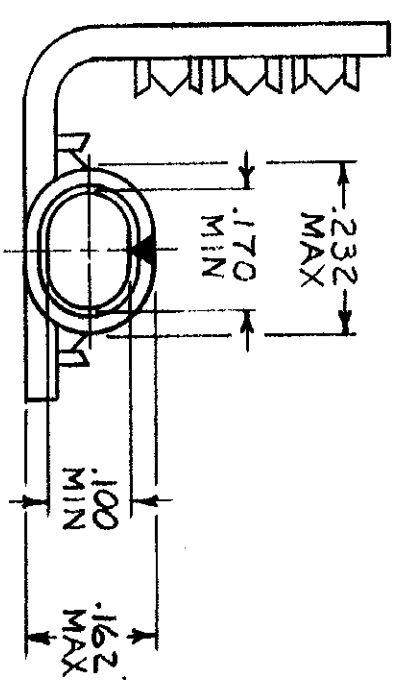
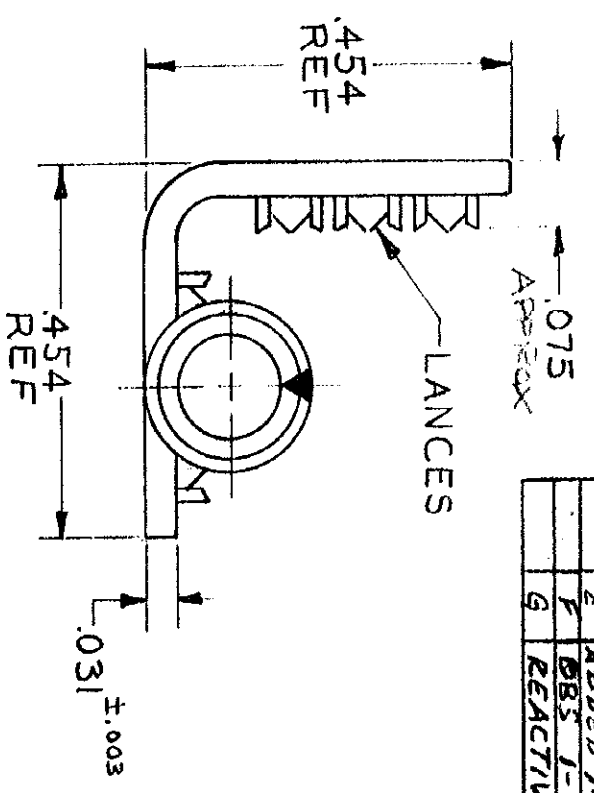
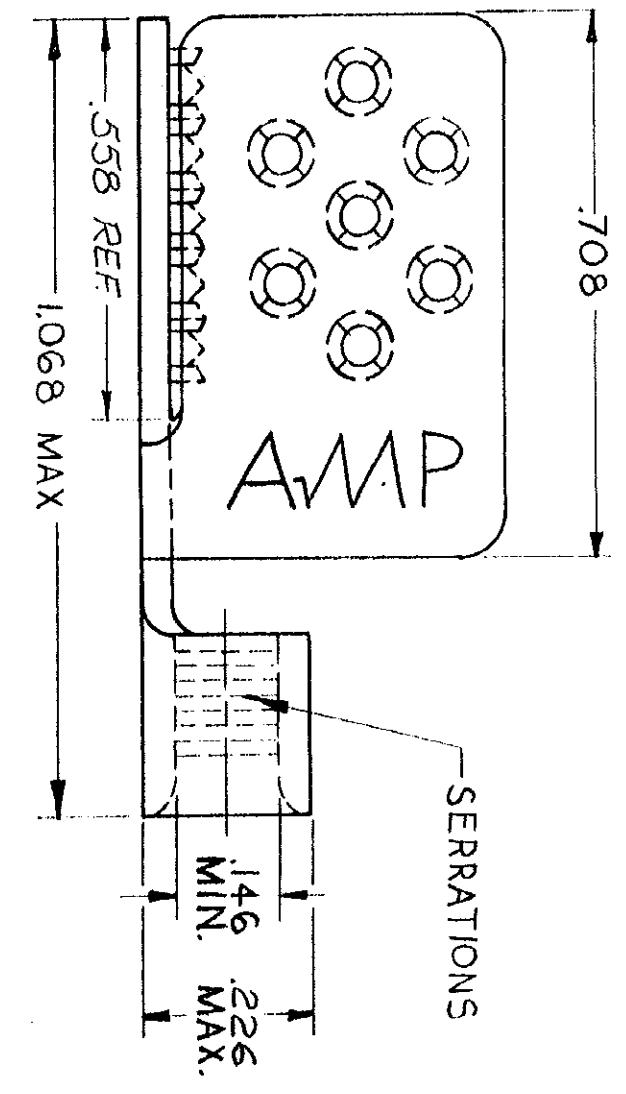

FORMED VIEW (BARREL) STYLE II

FORMED VIEW (BARREL) STYLE I

ZONE	LTR	REVISIONS	DESCRIPTION	DATE	APPROVED
O	NPS	G2-145G		3/27/67	RHM
A	ADDED REF	70.454 DIM ECN E-334		7/9/67	RHM
B	REV PER	D.S. 2.1.2		9-1-71	FCY
C	ADDED	1-330716-2 NPS 74-1806		12-16-74	R.M. [unclear]
D	ADDED	.558 REF DIM. - ECN PC7536		7/28/75	JM/102
E	ADDED	1-3 P84-0031		5-7-74	QUANIER
F	BBS	1-3 G-2841		8/15/82	182/m
G	REACTIVATE	1-3 G 4877		11-9-88	DKS/ [unclear]

1-330716-3	N/ PL (QQ-N-290) .0002 MIN EXT THK	II
1-330716-2	TIN PL (MIL-T-10727)	I
330716	NICKEL PL (QQ-N-290) .0002 MIN EXT THK	
PART NO.	FINISH	STYLE

UNLESS OTHERWISE SPECIFIED DIM. ARE IN INCHES. TOLERANCES ON: DECIMALS ±.008 ANGLES ±.5

MATERIAL: COPPER (QQ-C-576) ANNEALED

LOC PRINT DIST HEAT TREAT FINISH SEE TABLE

CONTRACT NO. 4-3-27-67

DR. Wm. Young

CHK. S. [unclear] 7/27/67

APPR. Barab [unclear] 3-31-67

DESIGNER [unclear] 12/16/64

OTHER APPR. [unclear]

AMP AMP INCORPORATED HARRISBURG, PENNSYLVANIA

NAME: WIRE TERMINAL

TERMI-FOIL SOLISTRAND

WIRE SIZE: 12-10

SIZE: B100779

CODE IDENT NO. NUMBER: 330716

SCALE: 4-1

WT. CALC ACTUAL

SHEET 1 OF 1

CUSTOMER DRAWING