

REVISIONS					
REV	DATE	DESCRIPTION	BY	CHK	APPV
E2	29JUN2022	REVISED PER ECR-22-142661	PJ	FL	
E3	11AUG2022	REVISED PER ECR-22-147279	PJ	FL	

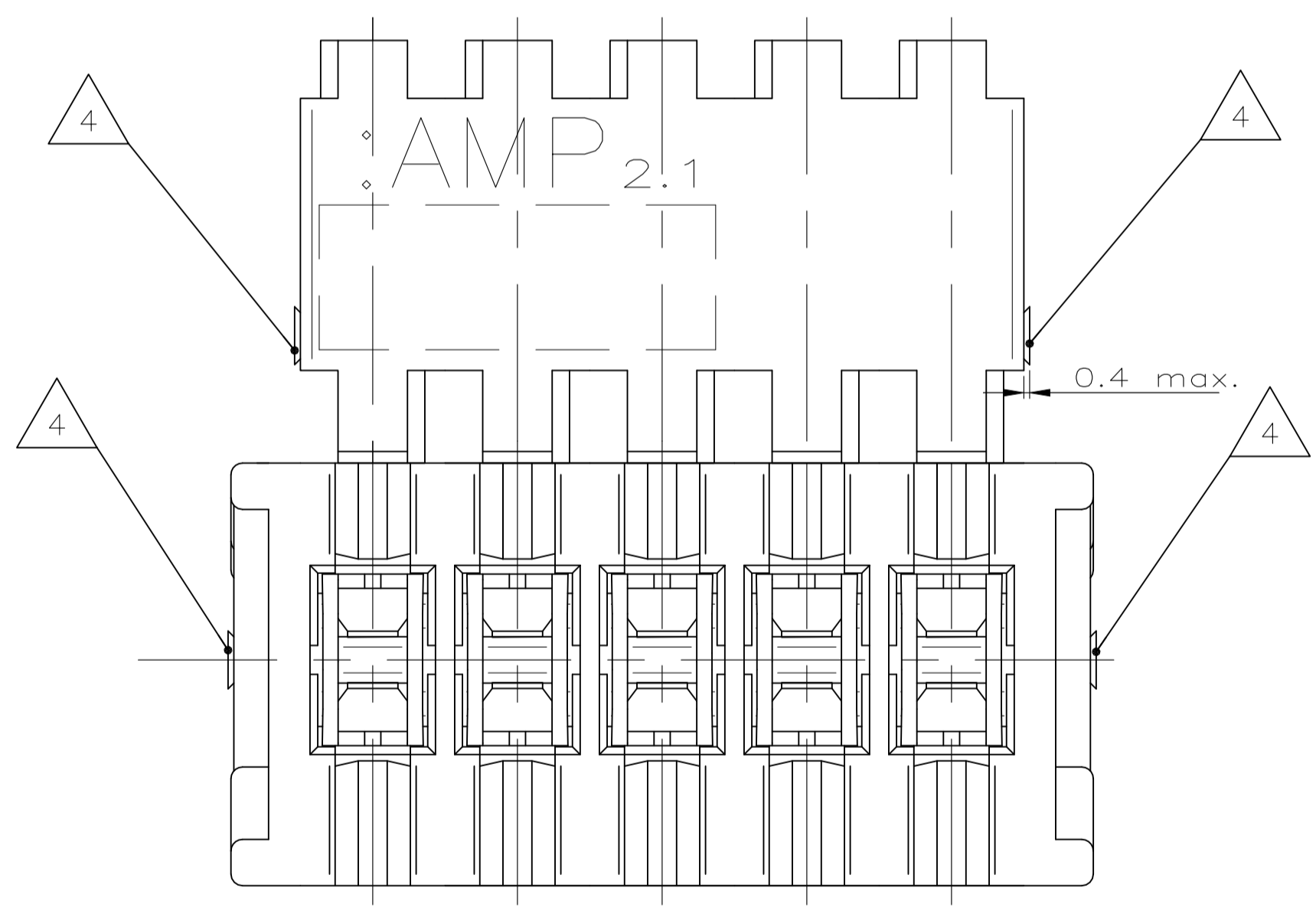
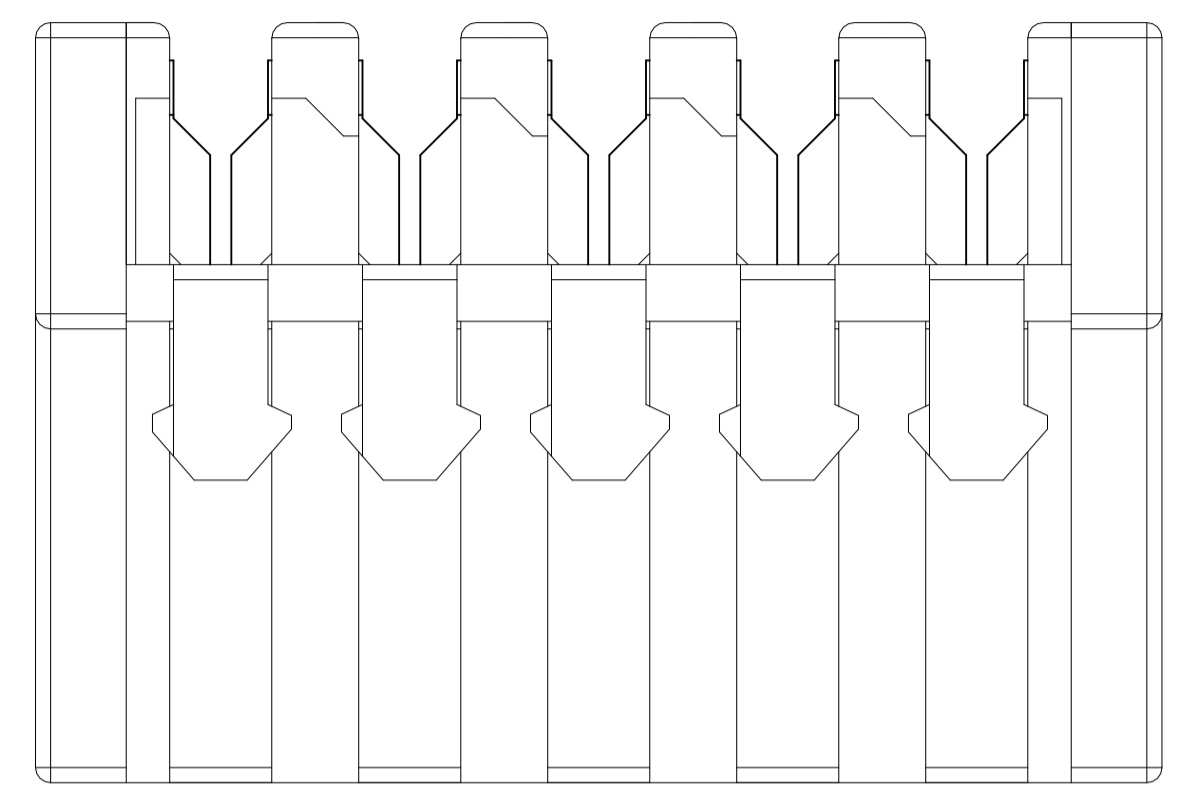
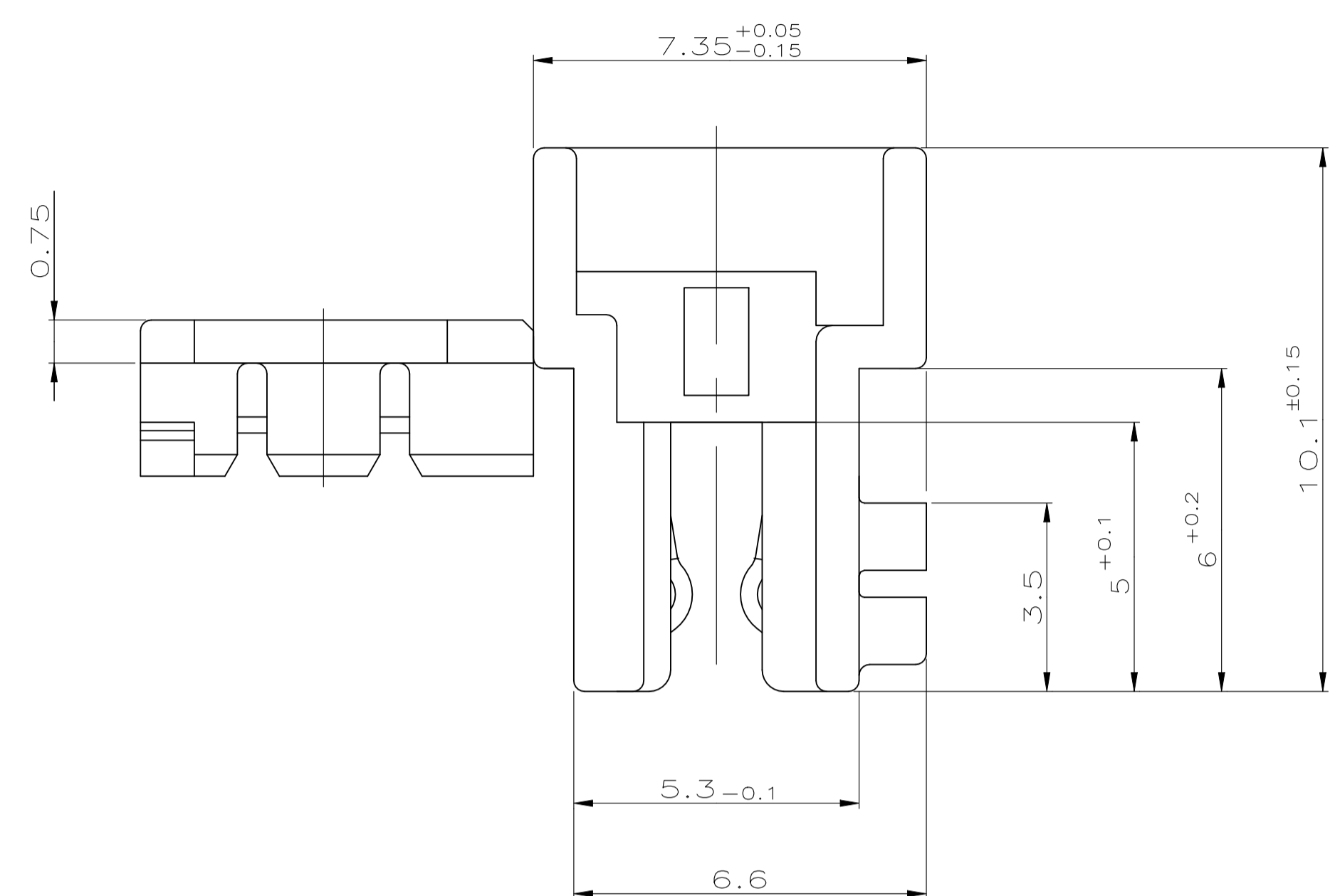
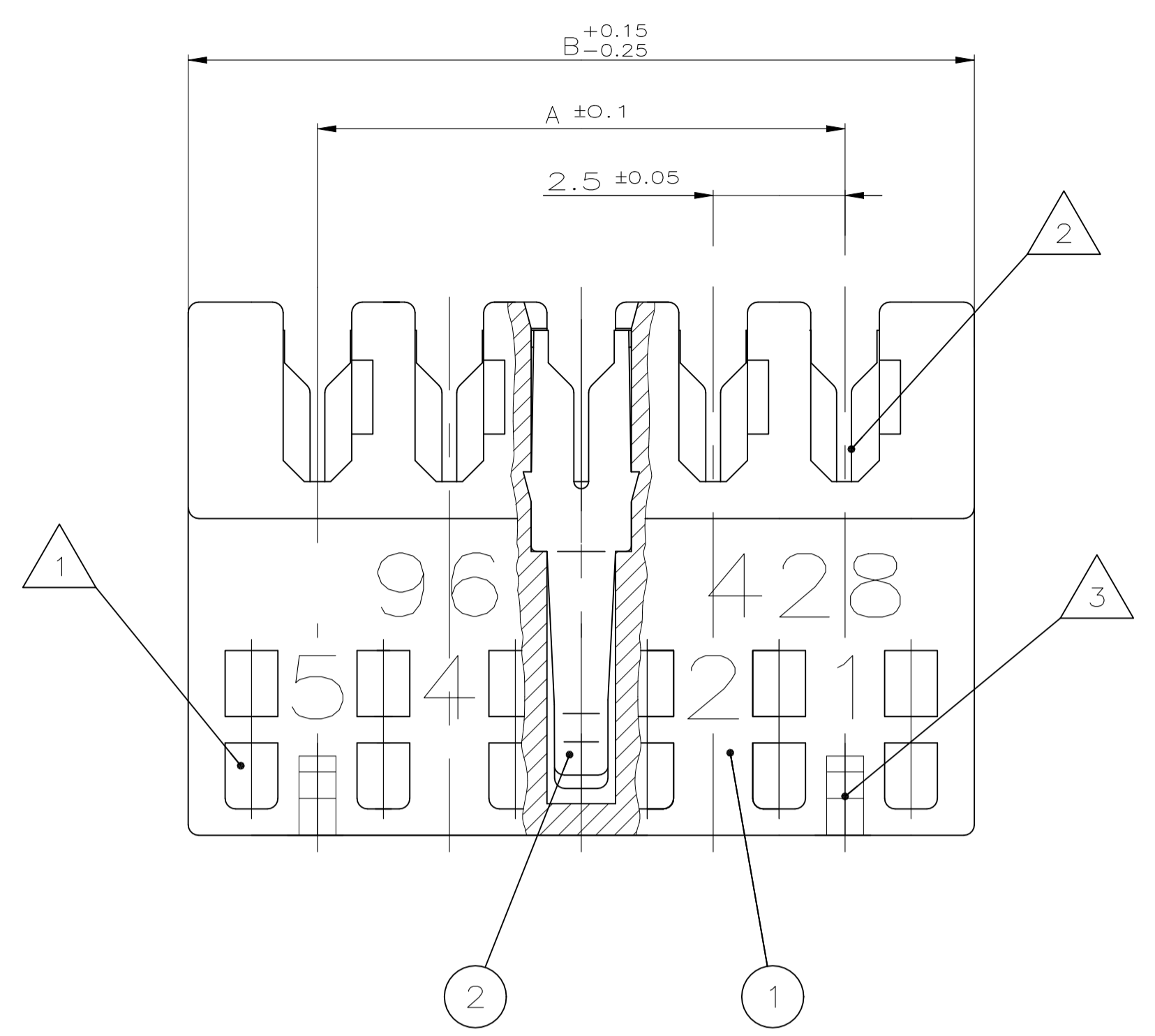

- 12 LOCKING FEATURE FOR INTERIOR LOCKING NOT PRESENT (NOTE 3 DOES NOT APPLY).
- 11 OBSOLETE.
- 10 PART RELEASED WITH PARTIAL VALIDATION AND PENDING AGENCY APPROVALS.
- 9 ALTERNATIVE RESIN PBT GF
- 8 PRELIMINARY PART, NOT YET RELEASED FOR PRODUCTION
- 7 PA GF, UL94-V0 & GWEPT 750 NO-FLAME, NATURAL
- 6 PBT GF
- 5 PASSENDE GEGENSTECKER:
 -TABWANNE SIEHE ZEICHNUNG 1971817 AND EQUIVALENT;
 -LEITERKARTENANSCHLUSS MIT RAHMEN SIEHE ZEICHNUNG 964 575
 -LEITERKARTENANSCHLUSS OHNE RAHMEN SIEHE SPEZIFIKATION 108-18056
 MATING PARTS:
 -TABHEADER SEE DRAWING NO. 1971817 AND EQUIVALENT;
 -PCB APPLICATION WITH FRAME SEE DRAWING 964 575
 -PCB APPLICATION WITHOUT FRAME SEE SPECIFICATION 108-18056
- 4 SCHNITTBEREICH DURCH HERSTELLUNGSPROZESS
CUTTING AREA FROM PRODUCING PROCESS
- 3 RASTMÖGLICHKEIT FÜR INNENVERRASTUNG AUF ANFRAGE
LOCKING FEATURE FOR INTERIOR LOCKING BY REQUEST
- 2 WIRE RANGE, DGB II (7xØ0.25=0.35mm²)
SEE APPLICATION SPECIFICATION 114-18049-1
- 1 KODIERRIPPEN; SCHNEIDEN AUF DER VERARBEITUNGSMASCHINE ÖM GLICH.
KEYING RIBS; CUTTING WITH THE TERMINATION MACHINE POSSIBLE

STICK	POS.	DIM A	DIM B	TE P/N	TE P/N	TE P/N
3x	20	47.5	52.4	1-966195-0	-	-
3x	19	45.0	49.9	1-966195-9	2311511-9	1-2404188-9
4x	18	42.5	47.4	1-966195-8	2311511-8	1-2404188-8
4x	17	40.0	44.9	1-966195-7	-	-
4x	16	37.5	42.4	1-966195-6	2311511-6	1-2404188-6
4x	15	35.0	39.9	1-966195-5	2311511-5	1-2404188-5
5x	14	32.5	37.4	1-966195-4	-	-
5x	13	30.0	34.9	1-966195-3	-	-
5x	12	27.5	32.4	1-966195-2	2311511-2	1-2404188-2
6x	11	25.0	29.9	1-966195-1	2311511-1	1-2404188-1
6x	10	22.5	27.4	1-966194-0	2-2311510-0	2-2403118-0
7x	9	20.0	24.9	1-966194-9	1-2311510-9	1-2403118-9
8x	8	17.5	22.4	1-966194-8	1-2311510-8	1-2403118-8
8x	7	15.0	19.9	1-966194-7	1-2311510-7	1-2403118-7
10x	6	12.5	17.4	1-966194-6	1-2311510-6	1-2403118-6
11x	5	10.0	14.9	1-966194-5	1-2311510-5	1-2403118-5
13x	4	7.5	12.4	1-966194-4	1-2311510-4	1-2403118-4
16x	3	5.0	9.9	1-966194-3	1-2311510-3	1-2403118-3

THIS DRAWING IS A CONTROLLED DOCUMENT.					DIN MASEK 31.03.93		TE Connectivity	
DIMENSIONS: mm					CHK BORMUTH 31.03.93		NAME	
TOLERANCES UNLESS OTHERWISE SPECIFIED:					PRODUCT SPEC		AMP DUOPLUG 2.5™ FEMALE CONNECTOR	
0 PLC ± -					APPLICATION SPEC		3-20 POSITION, DGB II	
1 PLC ± 0.2					114-18049-1		SIZE	
2 PLC ± -					WEIGHT 0		A1 00779	
3 PLC ± -					CUSTOMER DRAWING		SCALE 10:1	
4 PLC ± 1°					SHEET 1 of 1		REV E3	
ANGLES					DRAWING NO. 966194		SHEET 1 of 1	