

Overview

SEN-30007 is a quad (four) channel, high precision and high accuracy thermocouple shield based on the MAX31856 by Maxim Integrated and supplied in an Arduino R3 form factor. SEN-30007 is stocked in multiple thermocouple variants, as well as “universal” configurations. Mini flat-blade thermocouples are supported by the type-specific variants. Universal thermocouple types are supported by screw-terminal and spring-clamp variants using bare wire connections.



Features

- Quad MAX31856 Thermocouple
- Arduino R3 form factor
- B-, E-, J-, K-, N-, R-, S-, and T-type thermocouple support
- 19-bit hot-junction temperature resolution ($0.0078125^{\circ}\text{C}/\text{bit}$) with 0.15% TC voltage accuracy
- 6-bit cold junction resolution ($0.015625^{\circ}\text{C}/\text{bit}$) $\pm 0.7^{\circ}\text{C}$ accuracy
- Thermocouple nonlinearity correction
- Multi-fault detection: Short-to-Gnd, Short-to-Vcc, Open thermocouple
- 3.3V - 5.0V supply and digital IO range
- RoHS Compliant

Kit Includes

- SEN-30007-(x) quad TC shield
- Full stackable header kit (all 5 connectors must be installed)

Typical Applications

- Automotive temperature sensing (exhaust, coolant, brakes, etc)
- Industrial instrumentation
- Oven controls
- Home brewing controls
- Hobby applications

Description

Maxim has evolved their thermocouple measurement line from the MAX6674 and MAX6675, to the MAX31855, and now, the MAX31856. With the advent of the MAX31856, it is now possible to use a single IC to measure virtually any thermocouple type. However, care must still be taken to ensure consistent junction transitions to avoid unexpected errors. We accomplish this by offering the SEN-30007 in many different configurations. See Table 1 below for the different ordering codes, and the Appendix for pictures of the different configurations. [SEN-30008 is available](#) if a non-Arduino form factor is needed. We also offer [single-](#) and [dual-channel](#) breakout boards. There are many other [analog and digital solutions](#) offered if SEN-30007 doesn't quite fit your needs.

All of our SEN-30007 boards include analog filtering on each thermocouple channel. This includes both common- and differential-mode filtering, which compliments the on-chip notch filter for mains frequency noise (50hz or 60hz). This

Table 1: Orderable Parts

PwF Part No.	Connector	Thermocouple Type
SEN-30007-J	Mini-blade TC	J-type only
SEN-30007-K	Mini-blade TC	K-type only
SEN-30007-T	Mini-blade TC	T-type only
SEN-30007-ST	screw terminal	universal, bare wire
SEN-30007-W	push-release spring clamp	universal, bare wire

ensures a steady and reliable temperature reading.

Measurements from the MAX31856 are accessed via a 4-wire SPI interface. In the case of SEN-30007, SCK/MOSI/MISO signals are routed through the ICSP header. Chip selects for each IC are connected to D7-D10 by default, but onboard jumper resistors can be removed and fly-wires installed to connect CS lines to any digital-capable pin. This makes it possible to stack multiple SEN-30007 boards, achieving at least 12 thermocouple channels on a single Arduino! (see our [GitHub Page](#) for an example 12-channel MAX31856 datalogger)

While the MAX31856 is a 3.3V part, all SPI signals are level shifted to Vddio using high speed translator ICs. This makes the MAX31856 suitable for any Arduino R3 form factor device operating between 3.0V and 5.0V.

Application & Guide

SEN-30007 is designed for rapid setup and integration. We have provided several code examples on our [GitHub Page](#) designed to get you up and running quickly.

QuickStart

Start by soldering **all 5** stackable headers (or straight pin headers, not included) on the SEN-30007, using your Arduino as a

guide. Download the PwFusion example code from GitHub, flash your board, and connect a few thermocouples. Any thermocouple channel that isn't plugged will have an illuminated LED showing a fault on that channel (Open, in this case). Other channels will be reading via the serial monitor (be sure to set your baud rate to 115,200).

Advanced User

The PwFusion library can be used to change many of the settings on the MAX31856 based on descriptions in the datasheet. Things like the number of samples to average, notch filter frequency, faults to display, and high- and low-temperature triggers can all be configured via the SPI interface. It is recommended to spend some time with the MAX31856 datasheet once you have gotten the SEN-30007 up and running to ensure optimal performance in your application.

Common Issues

- Not installing all required headers. Power, Digital, and ICSP headers are *required* for operation
- Conflicting Chip Selects when stacking multiple Arduino shields
 - SEN-30007 uses D7-D10 by default, but you can switch this to anything by removing the CS jumper resistors and using fly wires to connect to the desired port pin
 - Remember, D0/D1 are used for serial, and D11-D13 for SPI. These can NOT be shared with CS pins
- Conflicting SPI modes when stacking multiple Arduino shields

- MAX31856 uses SPI Modes 1 or 3, while many Ethernet controllers and SD cards use Mode 0.
- Be sure to switch between modes before calling functions for the specific device you are talking to.
- We show an example of how to handle this in our [12-channel TC logger](#) example on GitHub
- Strange or inconsistent readings with multiple grounded thermocouples
 - Common mode range can result in erroneous readings when the thermocouple is grounded
 - MAX31856 is typically used for ungrounded thermocouple measurement
 - Try to select ungrounded thermocouples, when possible
 - If you see issues and must use grounded thermocouples, [contact us](#) to explore what we have available for isolated thermocouple products
- Difficulty soldering headers on SEN-30007 with mini-blade connectors
 - Stack multiple headers and invert on the back of an Arduino to get well-aligned headers for soldering

[SEN-30008](#): Quad MAX31856 TC breakout form factor

[SEN-30011](#): Quad MCP9601, Qwiic I2C interface, multiple thermocouple options

[IFB-10011](#): Qwiic-compatible I2C MUX based on TCA9548A

[WIR-10001](#): 10cm Qwiic-compatible interconnect cable

[SEN-30202](#): Dual MAX31865 RTD, SPI interface

Ordering Options & Related Parts

[SEN-30007-J](#): Quad MAX31856 TC shield, J-type flat-blade connectors

[SEN-30007-K](#): Quad MAX31856 TC shield, K-type flat-blade connectors

[SEN-30007-T](#): Quad MAX31856 TC shield, T-type flat-blade connectors

[SEN-30007-ST](#): Quad MAX31856 TC shield, screw terminal connectors

[SEN-30007-W](#): Quad MAX31856 TC shield, spring-clamp connector

[SEN-30005](#): Single MAX31856 Breakout

[SEN-30006](#): Dual MAX31856 Breakout

Appendix 1a: Mech Drawing, Mini Blade
(Top View)

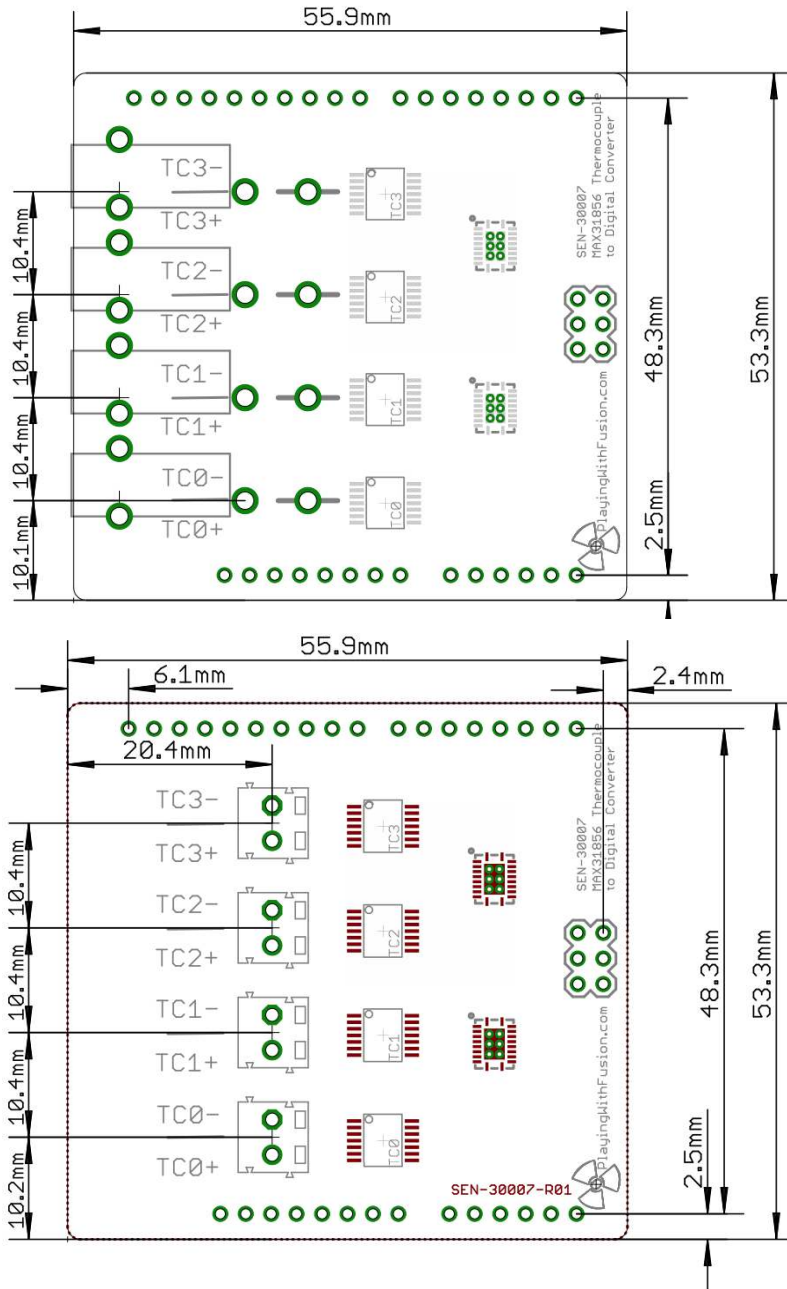

Appendix 1b: Mech Drawing, Screw
Terminal (Top View)

Appendix 2: Arduino Header Connections

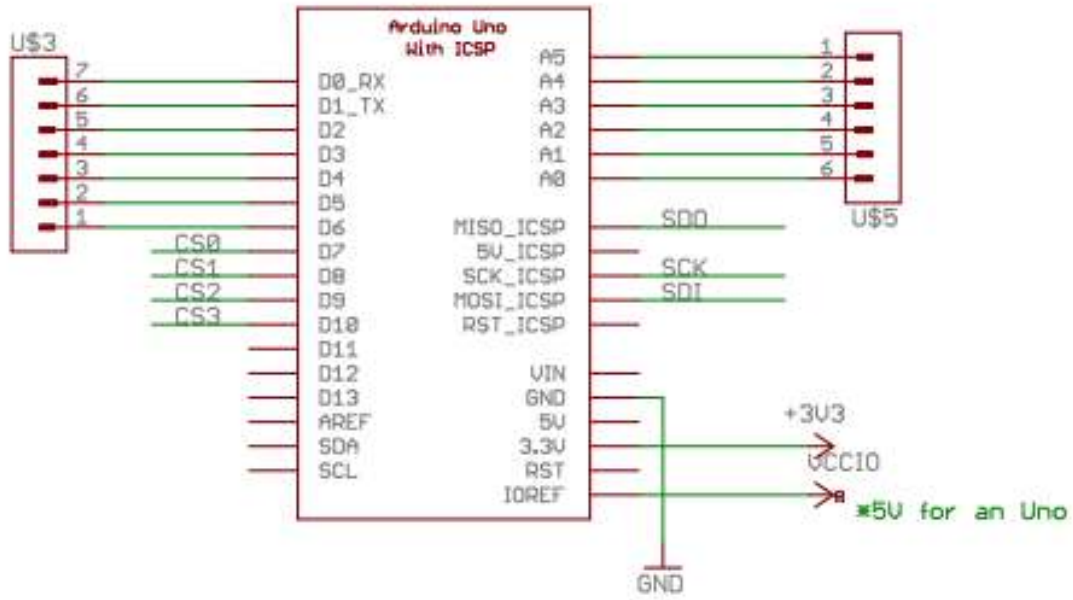

Appendix 3: CS Modification Instructions

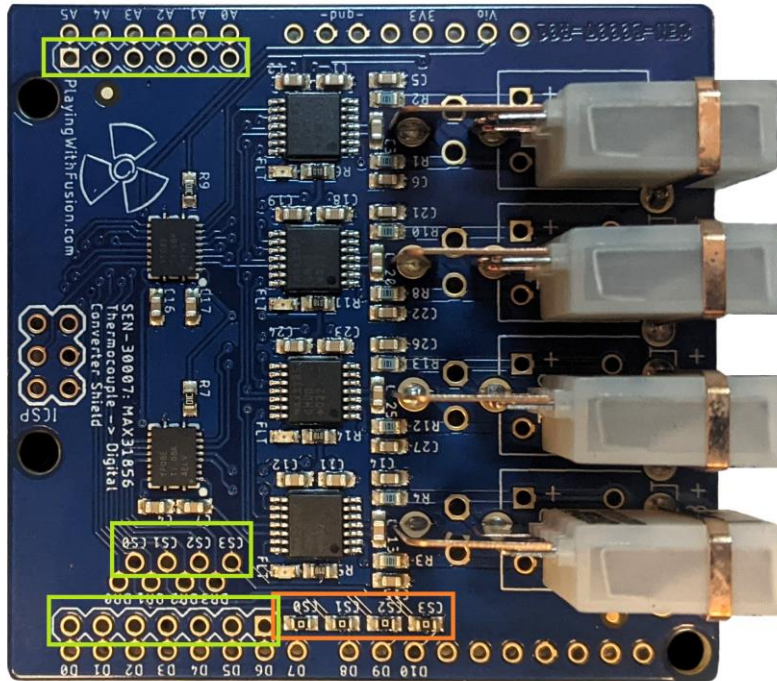

- 1) Remove CS jumper resistors (orange)
- 2) Connect fly wires between thru-hole pads labelled CS0-CS3 and your chosen alternative CS connection (green).

Note: analog pins can be used as digital IO

Note2: D0 and D1 are typically used for serial, and are not recommended for CS

Appendix 4b: SEN-30007, J-Type (R00)

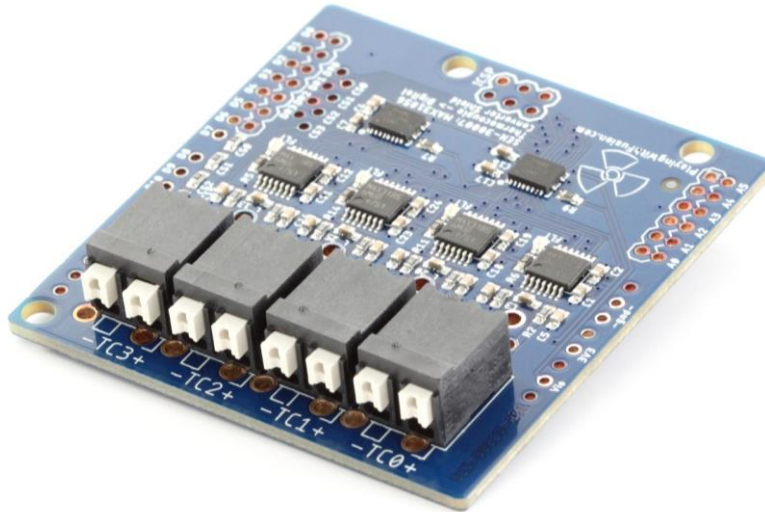

shown, see Appendix 3 for R01 layout)

Appendix 4a: SEN-30007, Spring Clamp
connector, pushbutton release

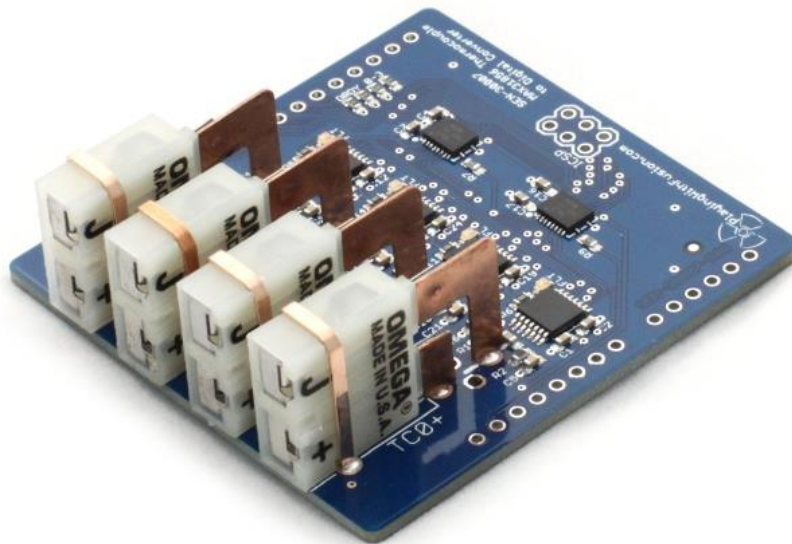

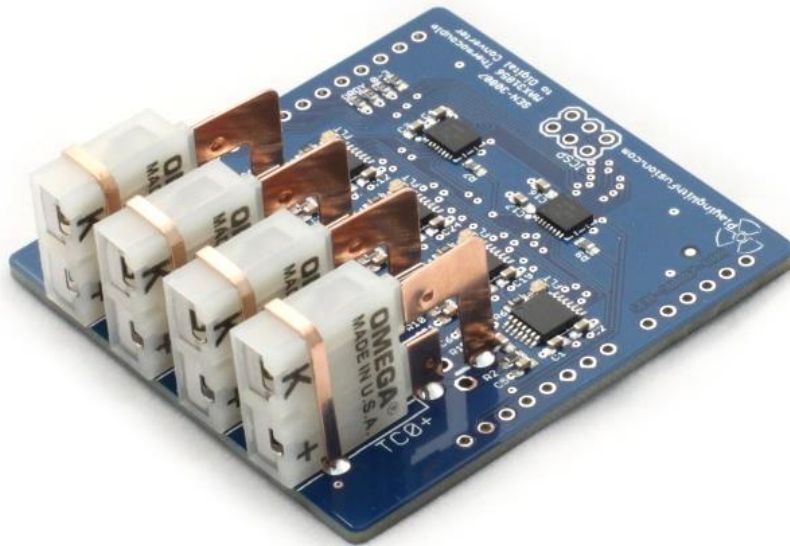

Appendix 4d: SEN-30007, T-Type (R00
shown, see Appendix 3 for R01 layout)

Appendix 4c: SEN-30007, K-Type (R00

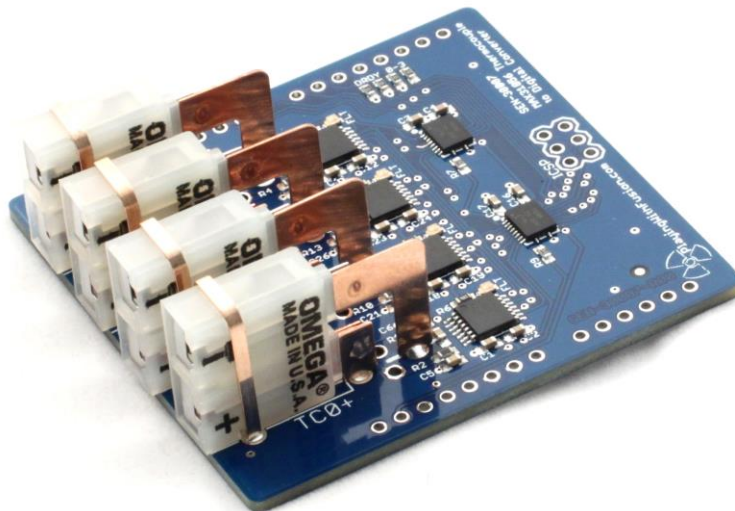

shown, see Appendix 3 for R01 layout)

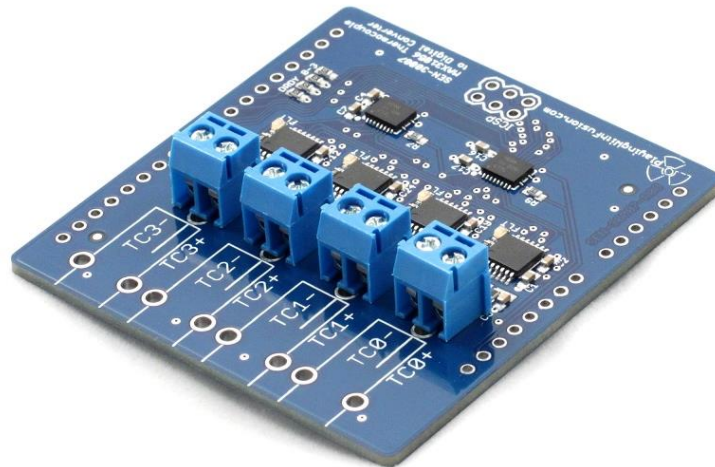

Appendix 4e: SEN-30007, Screw Terminal

Revision History

Date	Author	Notes
03/12/2021	J. Steinlage	Add pictures