



STEVAL-IPE010V2

Energy meter demonstration kit motherboard based on the STPMC1

Data brief

Features

- V_{nom} : 230 V_{RMS}
- I_{nom} CT: 1 A (I_{max} 30 A)
- I_{nom} Sh: 5 A (I_{max} 80 A)
- f_{LIN} : 50 / 60 ± 10% Hz
- Operating temperature: -40 - +85 °C
- RoHS compliant

Description

The purpose of the demonstration board is to provide an evaluation platform for the STPMC1 and STPMS2L devices, but it can also be used as a starting point to design a Class 1 meter for 2 to 4-wire power line systems using delta or wye service.

The STPMC1 is a metering ASSP implemented through an advanced 0.35 µm BCD6 technology.

The STPMS2L is an ASSP designed as a building block for single or multi-phase energy meters.

The STEVAL-IPE010V2 board is the motherboard based on the STPMC1 and works in conjunction with up to 5 STEVAL-IPE014V1 daughterboards (to be ordered separately), each with an STPMS2L mounted to sense the voltage and current of each phase.

Each phase is monitored by an independent daughterboard, in which an autonomous power supply is provided to the board itself and, once it is connected, also to the motherboard.

On this board, the STPMS2L device senses the phase current through a CT or a shunt sensor, and the phase voltage through a voltage divider.

The presence of dedicated networks greatly reduces the sampling (aliasing) noise and the crosstalk noise between voltage and current channels, increasing meter precision. The STPMS2L produces a sigma-delta stream, sent

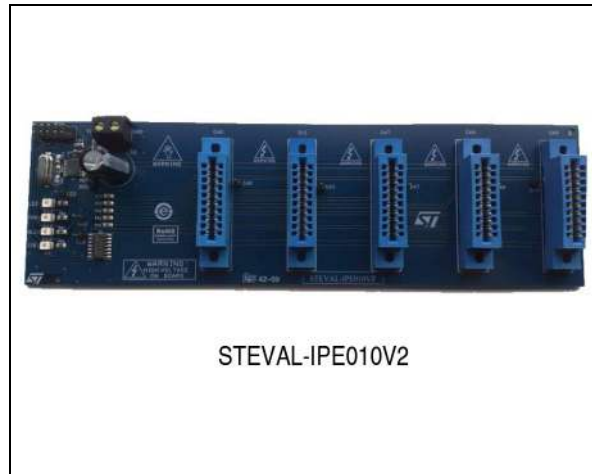

together with the supply voltage, to the STPMC1 through a card edge connector.

The STEVAL-IPE010V2 motherboard receives the sigma-delta streams from the daughterboards which are further elaborated by the STPMC1. This device, from a 4.194 MHz crystal oscillator, provides a common clock with programmable frequency to all the daughterboards.

The STEVAL-IPE010V2 motherboard, through a 10-pin flat cable connector, can be interfaced to a microprocessor board to implement advanced metering features (multi-tariff, data management and storage, communication, etc). It also has stepper motor connectors for simple energy meter implementation.

1 Schematic diagram

Figure 1. Circuit schematic

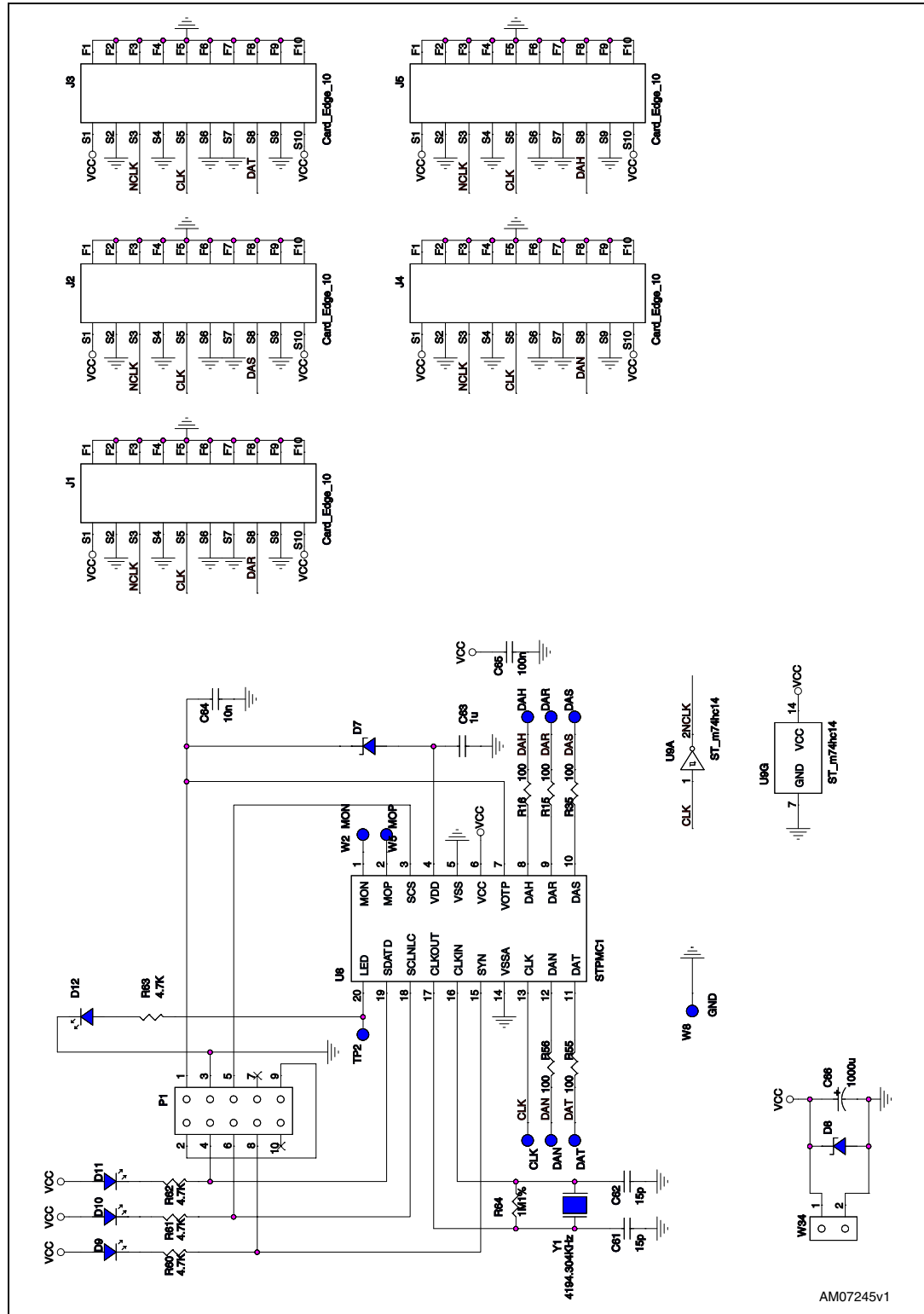

2 Revision history

Table 1. Document revision history

Date	Revision	Changes
01-Feb-2012	1	Initial release.
15-Feb-2012	2	Modified: description

Please Read Carefully:

Information in this document is provided solely in connection with ST products. STMicroelectronics NV and its subsidiaries ("ST") reserve the right to make changes, corrections, modifications or improvements, to this document, and the products and services described herein at any time, without notice.

All ST products are sold pursuant to ST's terms and conditions of sale.

Purchasers are solely responsible for the choice, selection and use of the ST products and services described herein, and ST assumes no liability whatsoever relating to the choice, selection or use of the ST products and services described herein.

No license, express or implied, by estoppel or otherwise, to any intellectual property rights is granted under this document. If any part of this document refers to any third party products or services it shall not be deemed a license grant by ST for the use of such third party products or services, or any intellectual property contained therein or considered as a warranty covering the use in any manner whatsoever of such third party products or services or any intellectual property contained therein.

UNLESS OTHERWISE SET FORTH IN ST'S TERMS AND CONDITIONS OF SALE ST DISCLAIMS ANY EXPRESS OR IMPLIED WARRANTY WITH RESPECT TO THE USE AND/OR SALE OF ST PRODUCTS INCLUDING WITHOUT LIMITATION IMPLIED WARRANTIES OF MERCHANTABILITY, FITNESS FOR A PARTICULAR PURPOSE (AND THEIR EQUIVALENTS UNDER THE LAWS OF ANY JURISDICTION), OR INFRINGEMENT OF ANY PATENT, COPYRIGHT OR OTHER INTELLECTUAL PROPERTY RIGHT.

UNLESS EXPRESSLY APPROVED IN WRITING BY TWO AUTHORIZED ST REPRESENTATIVES, ST PRODUCTS ARE NOT RECOMMENDED, AUTHORIZED OR WARRANTED FOR USE IN MILITARY, AIR CRAFT, SPACE, LIFE SAVING, OR LIFE SUSTAINING APPLICATIONS, NOR IN PRODUCTS OR SYSTEMS WHERE FAILURE OR MALFUNCTION MAY RESULT IN PERSONAL INJURY, DEATH, OR SEVERE PROPERTY OR ENVIRONMENTAL DAMAGE. ST PRODUCTS WHICH ARE NOT SPECIFIED AS "AUTOMOTIVE GRADE" MAY ONLY BE USED IN AUTOMOTIVE APPLICATIONS AT USER'S OWN RISK.

Resale of ST products with provisions different from the statements and/or technical features set forth in this document shall immediately void any warranty granted by ST for the ST product or service described herein and shall not create or extend in any manner whatsoever, any liability of ST.

ST and the ST logo are trademarks or registered trademarks of ST in various countries.

Information in this document supersedes and replaces all information previously supplied.

The ST logo is a registered trademark of STMicroelectronics. All other names are the property of their respective owners.

© 2012 STMicroelectronics - All rights reserved

STMicroelectronics group of companies

Australia - Belgium - Brazil - Canada - China - Czech Republic - Finland - France - Germany - Hong Kong - India - Israel - Italy - Japan - Malaysia - Malta - Morocco - Philippines - Singapore - Spain - Sweden - Switzerland - United Kingdom - United States of America

www.st.com