

New

BC3.5LFB1.4

LLC Full-Bridge 1.4:1 Transformer 3.5kW 70-200kHz

INDUCTIVE COMPONENTS / OBC TRANSFORMERS

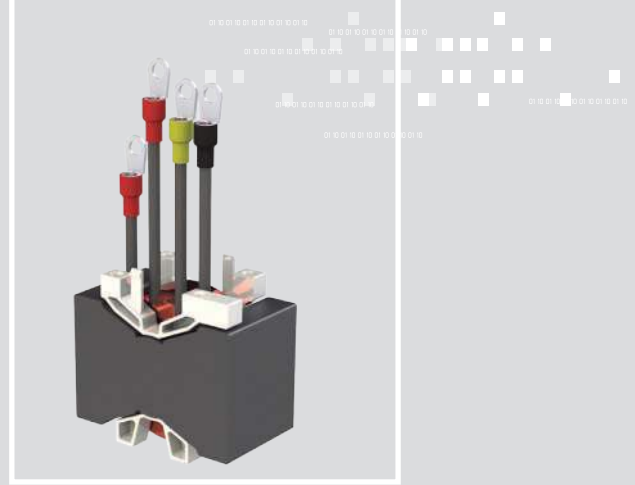

APPLICATIONS

- › Automotive EV/PHV AC/DC onboard battery chargers

01 FEATURES

- › LLC resonant 3.5 kW full-bridge transformer
- › Works with $L_r = 22\mu\text{H}$ and $C_r = 33\text{nF}$
- › Frequency range 70-200kHz
- › Reinforced insulation between prim/sec and with core
- › UL94 and RoHS materials (F/155°C)
- › Design based on AEC-Q200
- › Weight : approx 350grams

02 OPERATION

- › $V_{in} = 220-420\text{Vdc}$ / $V_{out} = 200-430\text{Vdc}$
- › $I_p = 19\text{Arms MAX}$ / $I_s = 18.5\text{Arms MAX}$
- › Operating temperature $-40/+140^\circ\text{C}$ with cooling (potting)

03 SPECIFICATIONS

DIMENSIONS

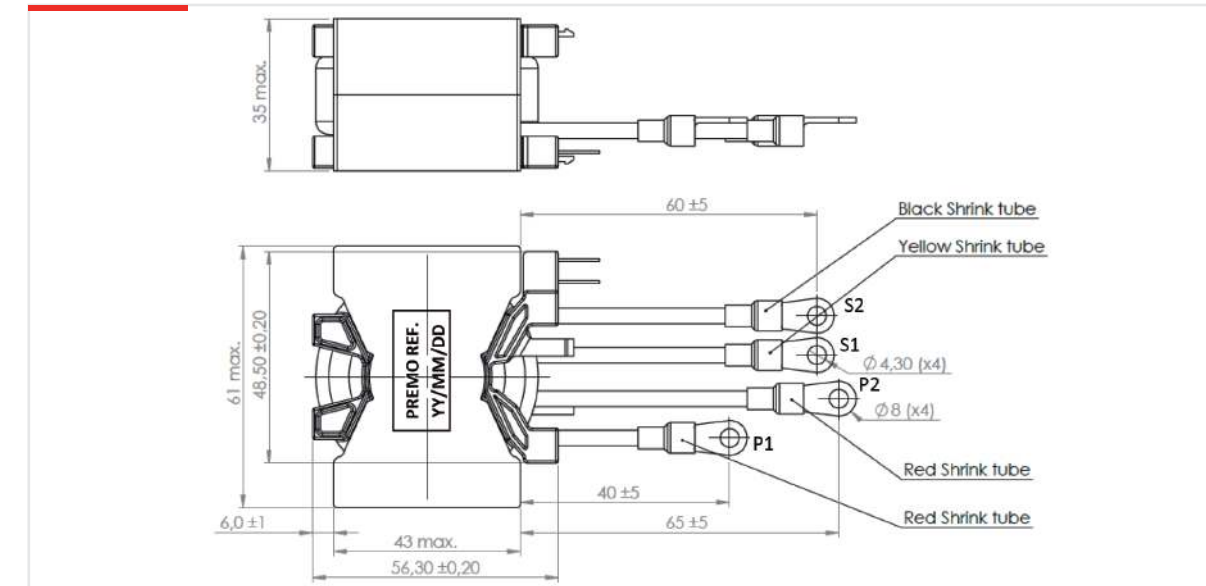

ELECTRICAL DIAGRAM

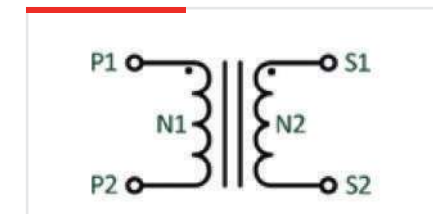

ELECTRICAL SPECIFICATIONS

INDUCTANCE at 25°C

$L_1 = L_p$ (100kHz/1Vac) 130 $\mu\text{H} \pm 7.5\%$

DC RESISTANCE at 25°C

R1 17m Ω TYP (19m Ω MAX)

R2 13m Ω TYP (15m Ω MAX)

TURN-RATIO

N1:N2 1.4:1

LEAKAGE INDUCTANCE

L1lk (100kHz/1Vac, N2 shorted) 2 μH MAX

DIELECTRIC STRENGTH

{N1}/{N2}/{CORE} 4kVAc/50Hz/5mA/1min*

{N2}/{CORE} 2kVAc/50Hz/3mA/1min*

(*) 1min in qualification / 2sec in mass production