

Description

The AP33772 is a highly integrated USB Type-C® PD3.0/PPS sink controller targeted for DC power request and control for USB Type-C connector-equipped devices (TCD). To leverage the increasing popularity of standard USB Type-C PD3.0 power adaptors, the AP33772 negotiates with an existing PD3.0 adaptor to acquire the required power profile to power the TCD.

For more flexible PD3.0 and PPS power applications that require direct voltage and current request with fine-tuning capabilities (20mV/Step, 50mA/Step), the AP33772 supports I2C communication: I2C Interface pins (SCL, SDA), I2C registers, and command settings for the host CPU of TCD to communicate with.

Rich power functions are embedded on the chip to reduce total BOM while maintaining maximum flexibility. A one-time-programming (OTP) ROM is provided for main firmware, and a multi-time-programming (MTP) ROM will be provided for user configuration purposes.

Features

- Compliant with USB PD Rev. 3.0 v1.2 with PPS
- PD sink controller with I2C bus communication
- Supports PPS with 20mV/step voltage and 50mA/step current
- Supports OTP (overtemperature protection), derating function
- Supports interrupt and its mask to a host MCU
- Supports status register for system monitor and control
- Supports flash FAULT LED indication for negotiation mismatch
- Supports OTP (one-time-programming) for main firmware
- Supports OVP with auto restart
- Supports OCP with auto restart
- Supports power-saving mode
- Supports driver for N-MOS VBUS power switch
- Supports dead-battery mode
- Operating voltage range: 3.3V to 24V
- MTP (multi-time-programming) is reserved for future configuration
- **Totally Lead-Free & Fully RoHS Compliant (Notes 1 & 2)**
- **Halogen and Antimony Free. “Green” Device (Note 3)**
- **For automotive applications requiring specific change control (i.e. parts qualified to AEC-Q100/101/104/200, PPAP capable, and manufactured in IATF 16949 certified facilities), please [contact us](mailto:contact@diodes.com) or your local Diodes representative. <https://www.diodes.com/quality/product-definitions/>**

Notes: 1. No purposely added lead. Fully EU Directive 2002/95/EC (RoHS), 2011/65/EU (RoHS 2) & 2015/863/EU (RoHS 3) compliant.
 2. See <https://www.diodes.com/quality/lead-free/> for more information about Diodes Incorporated’s definitions of Halogen- and Antimony-free, “Green” and Lead-free.
 3. Halogen- and Antimony-free “Green” products are defined as those which contain <900ppm bromine, <900ppm chlorine (<1500ppm total Br + Cl) and <1000ppm antimony compounds.

Pin Assignments

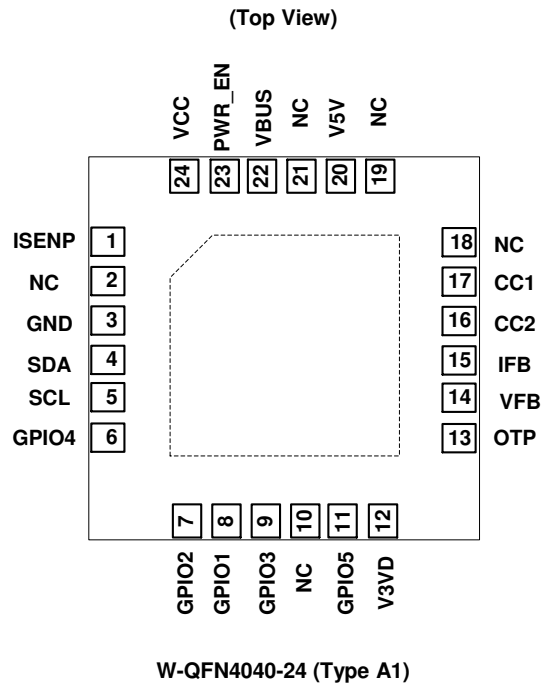

Applications

- USB Type-C connector-equipped battery-powered devices
- USB Type-C connector-equipped dc-power input devices
- USB PD3.0 PPS testers
- USB Type-C to traditional barrel-connector power-adaptor cables

Typical Applications Circuit

The AP33772 is a USB Type-C power delivery sink controller and used to request power from a standard USB PD source adapter, as shown in the figure 1 below.

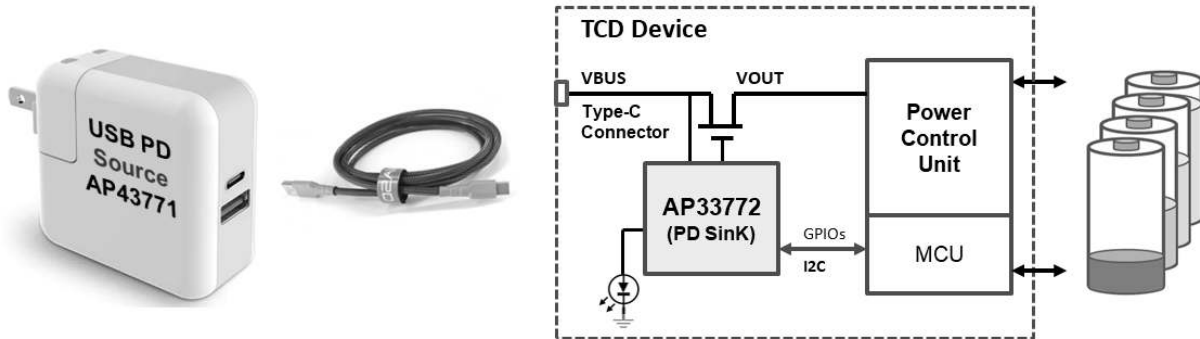

Figure 1. Typical Application structure of AP33772

The AP33772 request a power through I2C communication controlled by the host CPU of the TCD device. A typical AP33772 application circuit which uses I2C bus is shown as below.

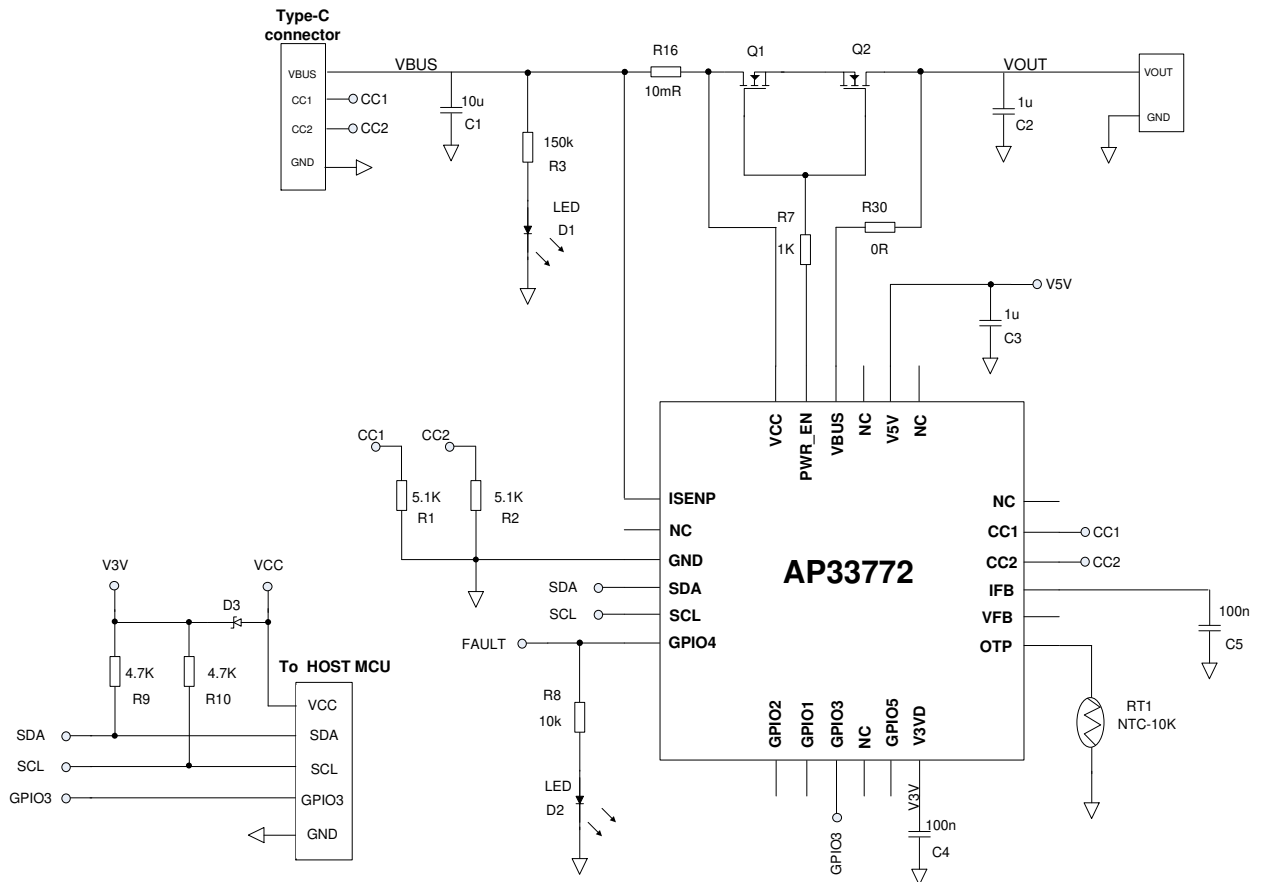

Figure 2. Typical Application Circuit of AP33772

Pin Descriptions

Pin No	Pin Name	Type (Note)	Pin Function
1	ISENP	AIO	Current Sense Positive Node.
2	NC	-	No Connection
3	GND	GND	Ground
4	SDA	DIO	I2C Data
5	SCL	DIO	I2C Clock
6	GPIO4	DIO	General-Purpose Input / Output, for LED usage
7	GPIO2	DIO	General-Purpose Input / Output
8	GPIO1	DIO	General-Purpose Input / Output
9	GPIO3	DIO	For Interrupt usage
10	NC	-	No Connection
11	GPIO5	DIO	General-Purpose Input / Output
12	V3VD	DP	3.3V LDO output. Power for Digital circuit and Digital I/O pins, with 100nF to Ground
13	OTP	AIO	Current Source Output. Can be connected to external NTC sensor for Overtemperature Protection.
14	VFB	AI	For Voltage Measurement.
15	IFB	AI	For Current Measurement, with 100nF to Ground
16	CC2	AIO	USB Type-C configuration channel 2
17	CC1	AIO	USB Type-C configuration channel 1
18	NC	-	No Connection
19	NC	-	No Connection
20	V5V	AP	5V LDO output. Power for Analog circuit and Analog I/O pins, with 1uF to Ground
21	NC	-	No Connection
22	VBUS	AHV	Terminal for Discharge Path.
23	PWR_EN	AHV	To control external NMOS switch ON (High) or OFF (Low).
24	VCC	AHV	The power supply of the IC, connected to a ceramic capacitor.
-	EP	GND	Exposed pad is connected to Ground

Note:

AHV– Analog High Voltage pin
 AP – Power for Analog Circuit and Analog I/O pins, 5.0V operation
 AI – Analog Input pin
 DP – Power for Digital Circuit and I/O pins, 3.3V operation
 AIO – Analog I/O pin.
 DIO – Digital I/O pin.

Functional Block Diagram

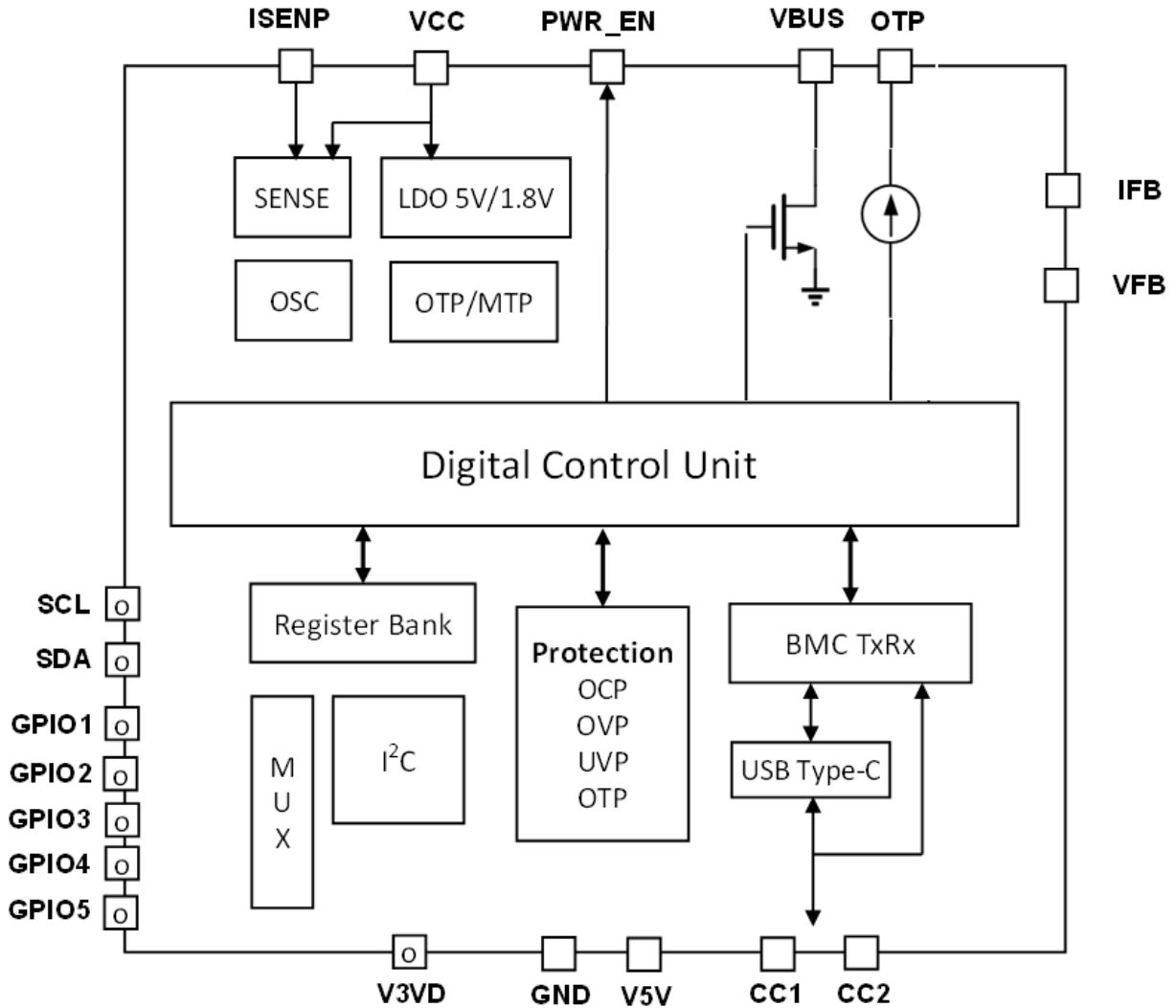

Absolute Maximum Ratings (Note 4)

Symbol	Parameter	Rating	Unit
V _{CC}	Input Voltage at VCC Pin	-0.3 to 24	V
V _{FB} , V _{IFB} , V _{OTP}	Input Voltage at VFB, IFB, OTP Pins	-0.3 to 7	V
V _{BUS} , V _{PWR_EN} , V _{ISENP}	Input Voltage at VBUS, PWR_EN, ISENP Pins	-0.3 to 24	V
—	Voltage from PWR_EN to VCC Pin	-16 to 7	V
V _{V5V}	Input Voltage at V5V Pin	-0.3 to 7	V
V _{V3VD}	Input Voltage at V3VD Pin	-0.3 to 5	V
V _{CC1} , V _{CC2}	Input Voltage at CC1, CC2 Pins	-0.3 to 7	V
V _{SCL} , V _{SDA} , V _{GPIO1 ~ GPIO5}	Input Voltage at SCL, SDA, GPIO1 ~ GPIO5 Pins	-0.3 to 5	V
T _J	Operating Junction Temperature	-40 to +150	°C
T _{STG}	Storage Temperature	-65 to +150	°C
T _{LEAD}	Lead Temperature (Soldering, 10s)	+300	°C
θ _{JA}	Thermal Resistance (Junction to Ambient) (Note 5)	28	°C/W
θ _{JC}	Thermal Resistance (Junction to Case) (Note 5)	16	°C/W
ESD	Human Body Model	2	kV
ESD	Charged Device Model	750	V

- Notes:
- Stresses greater than those listed under “*Absolute Maximum Ratings*” can cause permanent damage to the device. These are stress ratings only, and functional operation of the device at these or any other conditions beyond those indicated under “*Recommended Operating Conditions*” is not implied. Exposure to “*Absolute Maximum Ratings*” for extended periods can affect device reliability.
 - Test condition: Device mounted on FR-4 substrate PC board, 2oz copper, with the minimum footprint.

Recommended Operating Conditions

Symbol	Parameter	Min	Max	Unit
V _{CC}	Power Supply Voltage	3.3	24	V
V _{OTP}	Input Voltage at OTP Pin	0	3.7	V
V _{SDA} , V _{SCL}	Input Voltage at SDA, SCL Pins	0	3.7	V
V _{GPIO1 ~ GPIO5}	Input Voltage at GPIO1 ~ GPIO5 Pins	0	3.7	V
T _{OP}	Operating Temperature Range	-40	+85	°C

Electrical Characteristics (@ T_A = +25°C, unless otherwise specified.)

Symbol	Parameter	Condition	Min	Typ	Max	Unit
VCC SECTION						
V _{ST}	Startup Voltage	—	2.5	2.8	3.2	V
V _{UVLO}	Minimum Operating Voltage	—	2.4	2.7	3	V
V _{CC_HYS}	V _{CC} Hysteresis (V _{ST} -V _{UVLO})	—	0.05	—	—	V
I _{CC_OPR}	Operating Supply Current	V _{CC} = 5V	—	3.3	6	mA
CC1/CC2 SECTION						
V _{L_RD3A}	Low Voltage Threshold Used to Distinguish R _D Attached or Detached for 3A Delivery	—	—	1.35	—	V
V _{H_RD3A}	High Voltage Threshold Used to Distinguish R _D Attached or Detached for 3A Delivery	—	—	2.0	—	V
OTP SECTION						
I _{OTP}	OTP Pin Current Source (Note 7)	—	—	100	—	μA
I _{OTP_Range}	OTP Pin Current Source Range (Note 7)	—	-3	—	+3	%
R _{NTC}	NTC Resistance	—	—	10	—	kΩ
GPIO and I2C SECTION						
V _{GPIO_HI}	GPIO1~GPIO5 High Voltage (Note 7)	V _{CC} = 5V	1.4	—	—	V
V _{GPIO_LO}	GPIO1~GPIO5 Low Voltage (Note 7)	V _{CC} = 5V	—	—	0.4	V
I _{GPIO}	GPIO1~GPIO5 Sink/Source Capability (Note 7)	—	2	—	—	mA
V _{I2C_HI}	SDA, SCL High Voltage (Note 7)	V _{CC} = 5V	1.4	—	—	V
V _{I2C_LO}	SDA, SCL Low Voltage (Note 7)	V _{CC} = 5V	—	—	0.4	V
F _{SCL}	SCL Clock Frequency (Note 7)	—	—	—	400	kHz
PROTECTION FUNCTION SECTION						
V _{OVP5V}	OVP_5V Enable Voltage (Note 6, 7)	—	—	7	—	V
V _{OVP20V}	OVP_20V Enable Voltage (Note 6, 7)	—	—	22	—	V
t _{DEBOUNCE_OVP}	OVP Debounce Time (Note 8)	—	—	90	—	ms
I _{OVD}	Overvoltage Discharge Current	V _{CC} = 5V	150	200	250	mA
t _{OV_DELAY}	Delay from OVP Threshold Trip to NMOS Gate Turn-Off (Note 7)	—	—	—	50	μs
t _{OCP}	OCP Deglitch Time (Note 7)	—	—	30	—	ms

Notes: 6. 110% OVP setting @PDO>18V. PDO+2V OVP setting @PDO<=18V.
7. Guaranteed by design.
8. OVP blanking time during V_O transition from high output voltage to low output voltage, such as 9V to 5V, or 12V to 5V.

Performance Characteristics

Function Description

The AP33772 is a USB Type-C power delivery sink controller which meets USB Power Delivery specification Rev. 3.0 v1.2. Because of its high voltage process, the AP33772 provides a cost-effective solution without the need for external discrete high-voltage components like LDOs. During the protocol handshake process, packets are transmitted and received through a Biphase Mark Coding (BMC) transceiver with good eye diagram and high noise immunity. The AP33772 supports I2C communication to implement all of the PD sink functions, such as the requesting of power profiles—Power Device Objects (PDO) and Augmented Power Device Objects (APDO). The on-chip OTP/ MTP memories are used to store main protocol decoding and application programs as well as system configuration parameters. The on-chip multiple-channel ADC converter can be used to sense internal and outside signal variations to support various system status updates and controls accordingly.

CC Interface and BMC Transceiver

For high inter-operability consideration, CC interface detection and BMC transceivers are specially considered to maintain tolerance and noise immunity.

USB Power Delivery Sink Controller

To be compliant with critical USB Power Delivery specification Rev. 3.0 v1.2, the AP33772 is optimally implemented based on a flexible MCU+OTP design style and blended with dedicated hardware circuitry. Leveraging the MCU+OTP design, the AP33772 supports built-in PD3.0 PPS sink-controller-compliant firmware and useful application firmware, which can be requested through the I2C interface by the host MCU for any TCD design.

Sink PDO and APDO Capability

The AP33772 provides search algorithm for fixed PDO and PPS APDO, where 20mV/step voltage resolution and 50mA/step current resolution for power management are supported.

OCP and Rsense

The AP33772 supports OCP to control the output load condition. When the OCP function is enabled, the AP33772 monitors the output current through detection of IR drop on the 10mΩ Rsense resistor. Once the TCD device draws more current than the OCP threshold level, the AP33772 enables OCP by turning off the NMOS VBUS switch. OCP threshold level can also be configured through I2C communication during the AP33772 initialization.

NMOS VBUS Switch Control

With the embedded on-chip gate driver, the AP33772 works with an external NMOS switch for many different controls and protections. To combine it with VBUS voltage and current-sensing circuitry, the AP33772 is used for systems requiring reliable power from USB PD sources. Any non-PD source connected to an A33772-embedded TCD will trigger a mismatch during the power-request process. The VBUS will get to 5V, MOS VBUS switch will turn off, and the LED will start flickering accordingly.

OVP/OTP Protection

The AP33772 implements OVP feature by sending hard reset to the PD source when VBUS is higher than OVP voltage. As soon as OVP is triggered, the AP33772 provides internal discharge path to reduce the overvoltage condition. Thermal management of a TCD is a crucial safety design consideration. The temperature sensing of the TCD is enabled by connecting a 10kΩ NTC (Negative Temperature Coefficient) thermistor between the OTP pin and ground nearby a potential hot spot. The characteristic data of temperature vs. resistance values at four temperature points (25°C, 50°C, 75°C, 100°C) of the NTC thermistor needs to be set by the user through I2C (TR25, TR50, TR75, and TR100 Register). Leveraging the built-in multiple-channel ADC and application firmware, the AP33772 calculates the actual temperature and stores in the relevant register (TEMP). The AP33772 also implements useful features such as OTP (OTPTHR Register) and thermal power derating (DRTHU Register).

I2C Support

The I2C functions of the AP33772 are enabled by three pins—SDA (Pin 4—I2C data), SCL (Pin 5—I2C Clock), and GPIO3 (Pin 9—Interrupt). The host MCU of the TCD, functioning as the I2C master, writes proper contents to the relevant I2C register of the AP33772, working as an I2C slave device, to specify desired power profiles and various protection features. It also accesses the AP33772 for various statuses to take proper actions and maintain normal functions of the TCD during the charging process.

I2C Command/Register Summary

The AP33772, functioning as an I2C slave device, has the assigned slave physical address 0x51. The I2C read and write operations are supported as below. All commands (CMDs) are summarized in the following I2C Register Map table. The AP33772 can be monitored and controlled by the I2C commands.

All transactions begin with a START (S) and end with a STOP (P). A START condition is defined as a HIGH to LOW transition of the SDA while SCL is HIGH. A STOP condition is defined as a LOW to HIGH transition of the SDA while SCL is HIGH. START and STOP conditions are always generated by the I2C master, the host MCU of the TCD.

I2C Format for Write Data:



I2C Format for Read Data:

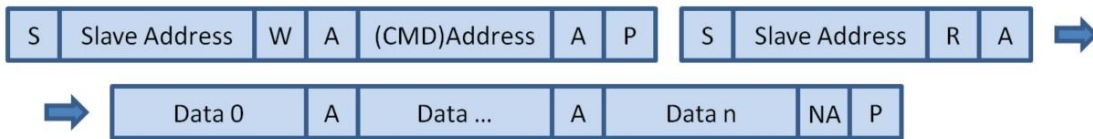

I2C Register Map

Register Content	I2C Address	Length	Attribute	Pwr-on	Description
SRCPDO	0x00	28	RO	All 00h	PDO used to expose PD Source (SRC) power capabilities. Total length is 28 bytes
PDONUM	0x1C	1	RO	00h	Valid source PDO number
STATUS	0x1D	1	RC	00h	AP33772 status
MASK	0x1E	1	RW	01h	Interrupt enable mask
VOLTAGE	0x20	1	RO	00h	LSB 80mV
CURRENT	0x21	1	RO	00h	LSB 24mA
TEMP	0x22	1	RO	19h	Temperature, Unit: °C
OCPTHTR	0x23	1	RW	00h	OCPTHTR threshold, LSB 50mA
OTPTHTR	0x24	1	RW	78h	OTP threshold, Unit: °C
DRTHTR	0x25	1	RW	78h	De-rating threshold, Unit: °C
TR25	0x28	2	RW	2710h	Thermal Resistance @25°C, Unit: Ω
TR50	0x2A	2	RW	1041h	Thermal Resistance @50°C, Unit: Ω
TR75	0x2C	2	RW	0788h	Thermal Resistance @75°C, Unit: Ω
TR100	0x2E	2	RW	03CEh	Thermal Resistance @100°C, Unit: Ω
RDO	0x30	4	WO	00000000h	Request Data Object (RDO) is use to request power capabilities.

Attribute Convention

- RW: Readable / Writable
- RO: Read-Only
- RC: Read-Clear
- WO: Write-Only

Ordering Information

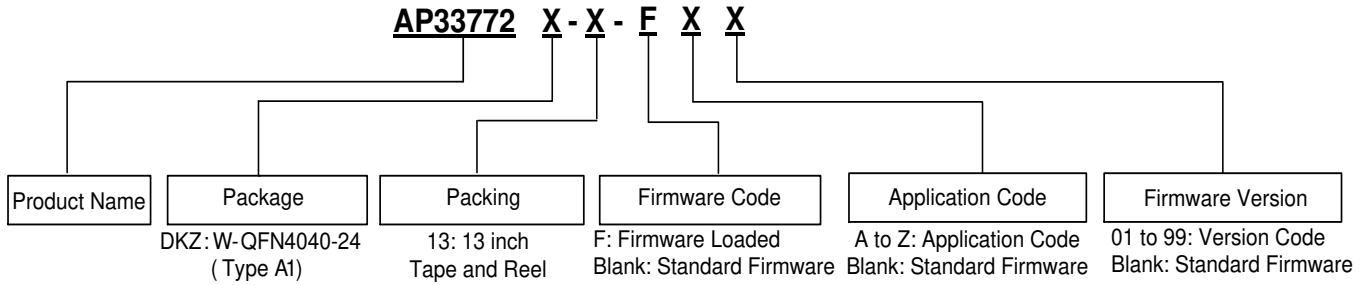

Orderable Part Number	Package	Identification Code	Packing		
			Quantity	Carrier	Part Number Suffix
AP33772DKZ-13-FXX	W-QFN4040-24 (Type A1)	6E	3,000	13" Tape and Reel	-13

Marking Information

W-QFN4040-24 (Type A1)

(Top View)

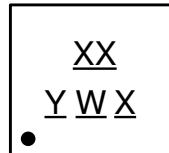

- XX : Identification Code
- Y : Year : 0~9
- W : Week : A~Z : 1~26 week;
a~z : 27~52 week; z represents 52 and 53 week
- X : Internal Code

Package Outline Dimensions

Please see <http://www.diodes.com/package-outlines.html> for the latest version.

W-QFN4040-24 (Type A1)

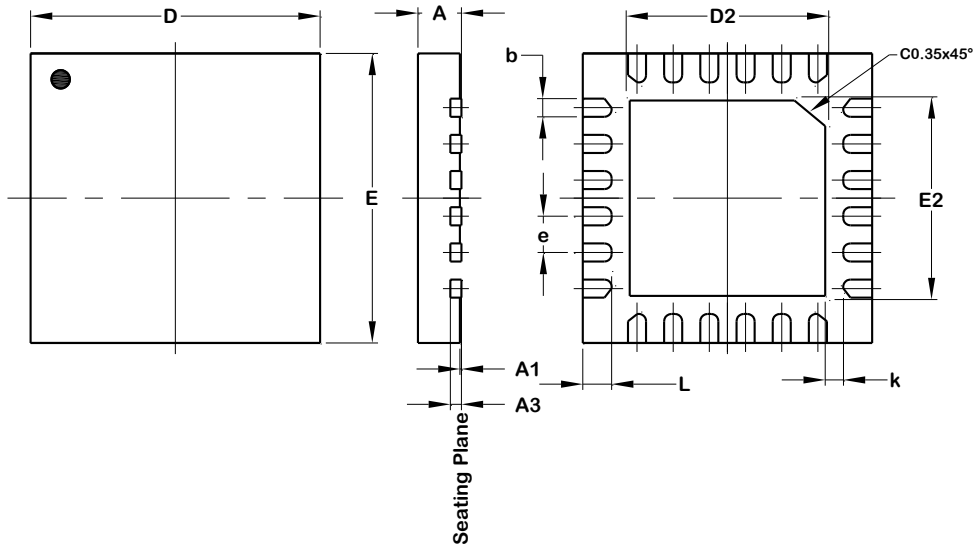

W-QFN4040-24 (Type A1)			
Dim	Min	Max	Typ
A	0.70	0.80	0.75
A1	0.00	0.05	0.02
A3	0.203 REF		
b	0.18	0.30	0.25
D	4.00 BSC		
D2	2.65	2.75	2.70
E	4.00 BSC		
E2	2.65	2.75	2.70
e	0.50 BSC		
k	0.20	--	--
L	0.35	0.45	0.40
All Dimensions in mm			

Suggested Pad Layout

Please see <http://www.diodes.com/package-outlines.html> for the latest version.

W-QFN4040-24 (Type A1)

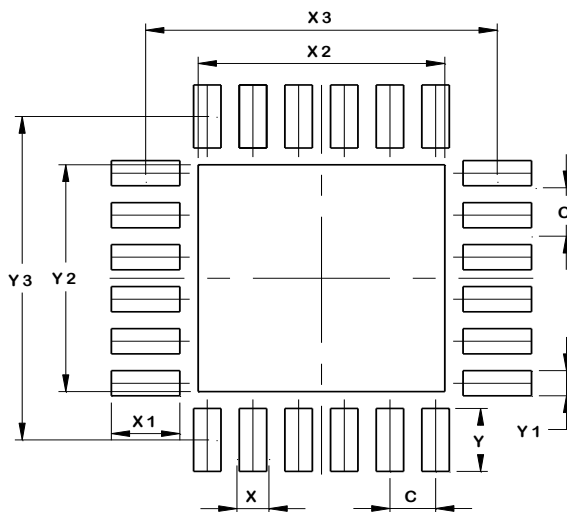

Dimensions	Value (in mm)
C	0.500
X	0.300
X1	0.750
X2	2.700
X3	3.850
Y	0.750
Y1	0.300
Y2	2.700
Y3	3.850

Mechanical Data

- Moisture Sensitivity: Level 1 per J-STD-020
- Terminals: Finish – Matte Tin Plated Leads, Solderable per J-STD-202 ②
- Weight: 0.041 grams (Approximate)

IMPORTANT NOTICE

1. DIODES INCORPORATED (Diodes) AND ITS SUBSIDIARIES MAKE NO WARRANTY OF ANY KIND, EXPRESS OR IMPLIED, WITH REGARDS TO ANY INFORMATION CONTAINED IN THIS DOCUMENT, INCLUDING, BUT NOT LIMITED TO, THE IMPLIED WARRANTIES OF MERCHANTABILITY, FITNESS FOR A PARTICULAR PURPOSE OR NON-INFRINGEMENT OF THIRD PARTY INTELLECTUAL PROPERTY RIGHTS (AND THEIR EQUIVALENTS UNDER THE LAWS OF ANY JURISDICTION).
2. The Information contained herein is for informational purpose only and is provided only to illustrate the operation of Diodes' products described herein and application examples. Diodes does not assume any liability arising out of the application or use of this document or any product described herein. This document is intended for skilled and technically trained engineering customers and users who design with Diodes' products. Diodes' products may be used to facilitate safety-related applications; however, in all instances customers and users are responsible for (a) selecting the appropriate Diodes products for their applications, (b) evaluating the suitability of Diodes' products for their intended applications, (c) ensuring their applications, which incorporate Diodes' products, comply the applicable legal and regulatory requirements as well as safety and functional-safety related standards, and (d) ensuring they design with appropriate safeguards (including testing, validation, quality control techniques, redundancy, malfunction prevention, and appropriate treatment for aging degradation) to minimize the risks associated with their applications.
3. Diodes assumes no liability for any application-related information, support, assistance or feedback that may be provided by Diodes from time to time. Any customer or user of this document or products described herein will assume all risks and liabilities associated with such use, and will hold Diodes and all companies whose products are represented herein or on Diodes' websites, harmless against all damages and liabilities.
4. Products described herein may be covered by one or more United States, international or foreign patents and pending patent applications. Product names and markings noted herein may also be covered by one or more United States, international or foreign trademarks and trademark applications. Diodes does not convey any license under any of its intellectual property rights or the rights of any third parties (including third parties whose products and services may be described in this document or on Diodes' website) under this document.
5. Diodes' products are provided subject to Diodes' Standard Terms and Conditions of Sale (<https://www.diodes.com/about/company/terms-and-conditions/terms-and-conditions-of-sales/>) or other applicable terms. This document does not alter or expand the applicable warranties provided by Diodes. Diodes does not warrant or accept any liability whatsoever in respect of any products purchased through unauthorized sales channel.
6. Diodes' products and technology may not be used for or incorporated into any products or systems whose manufacture, use or sale is prohibited under any applicable laws and regulations. Should customers or users use Diodes' products in contravention of any applicable laws or regulations, or for any unintended or unauthorized application, customers and users will (a) be solely responsible for any damages, losses or penalties arising in connection therewith or as a result thereof, and (b) indemnify and hold Diodes and its representatives and agents harmless against any and all claims, damages, expenses, and attorney fees arising out of, directly or indirectly, any claim relating to any noncompliance with the applicable laws and regulations, as well as any unintended or unauthorized application.
7. While efforts have been made to ensure the information contained in this document is accurate, complete and current, it may contain technical inaccuracies, omissions and typographical errors. Diodes does not warrant that information contained in this document is error-free and Diodes is under no obligation to update or otherwise correct this information. Notwithstanding the foregoing, Diodes reserves the right to make modifications, enhancements, improvements, corrections or other changes without further notice to this document and any product described herein. This document is written in English but may be translated into multiple languages for reference. Only the English version of this document is the final and determinative format released by Diodes.
8. Any unauthorized copying, modification, distribution, transmission, display or other use of this document (or any portion hereof) is prohibited. Diodes assumes no responsibility for any losses incurred by the customers or users or any third parties arising from any such unauthorized use.
9. This Notice may be periodically updated with the most recent version available at <https://www.diodes.com/about/company/terms-and-conditions/important-notice>

The Diodes logo is a registered trademark of Diodes Incorporated in the United States and other countries.
All other trademarks are the property of their respective owners.
© 2023 Diodes Incorporated. All Rights Reserved.

www.diodes.com