

THIS DRAWING IS UNPUBLISHED. RELEASED FOR PUBLICATION
 © COPYRIGHT - TE Connectivity Ltd. ALL RIGHTS RESERVED.

REVISIONS				
P	LTR	DESCRIPTION	DATE	APVD
L		REVISED PER ECO-18-007010	23MAY2018	KH MZ

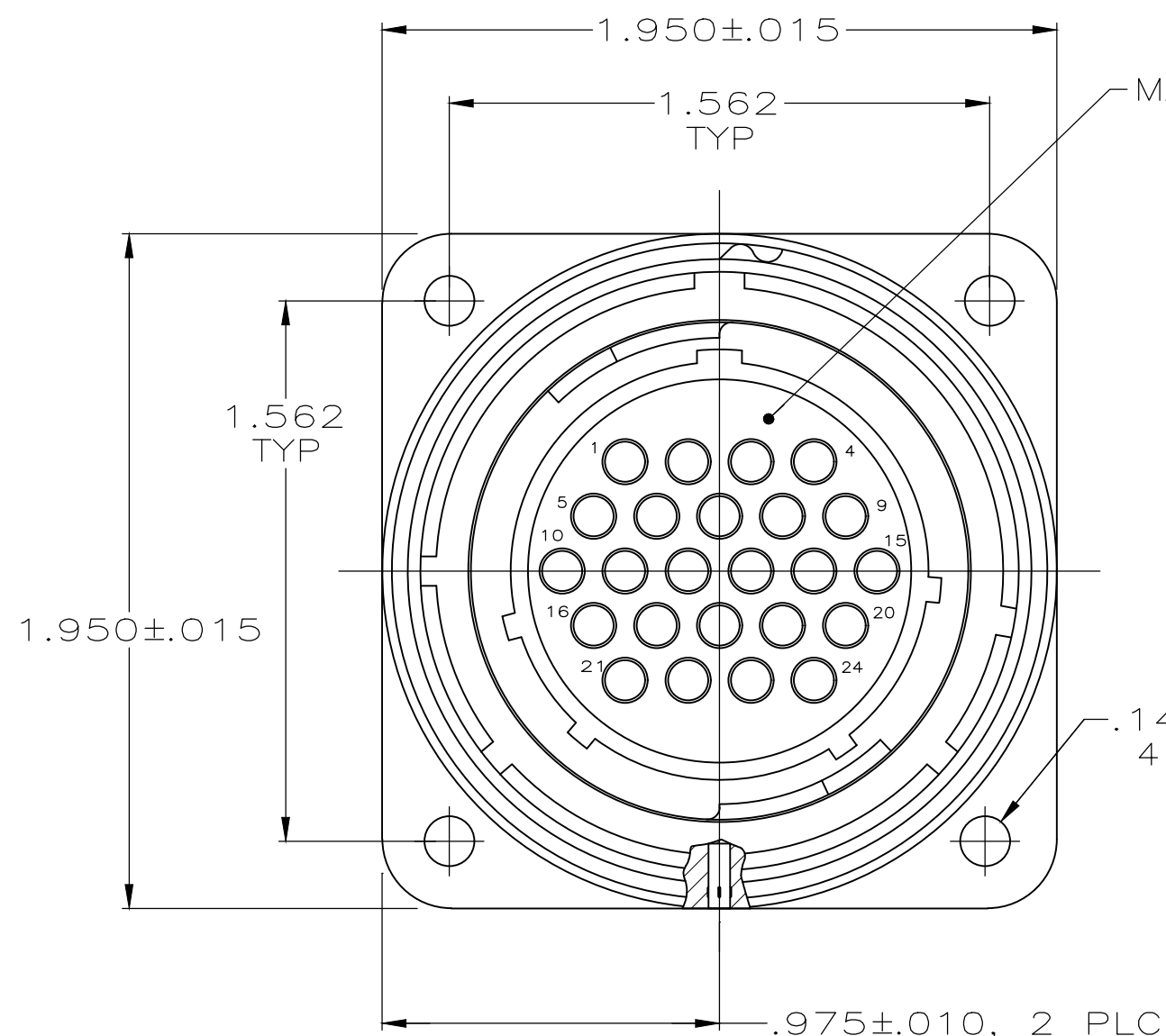

MATING FACE
 RECEPTACLE, STD SEX ARRANGEMENT 23-24
 MATERIAL: THERMOPLASTIC
 COLOR: BLACK
 METAL SHELL RECEPTACLE
 MATERIAL: ZINC ALLOY
 FINISH: NICKEL PLATED
 PER QQ-N-290
 GROOVED PIN, 2 PLC
 MATERIAL: STEEL ALLOY
 FINISH: NICKEL PLATED
 PER QQ-N-290

PERIPHERAL SEAL
 SEE TABLE

1.900 MAX

.125 MAX
 PANEL THK

.875 ± 0.010

.125 ± 0.010

1.555 MAX

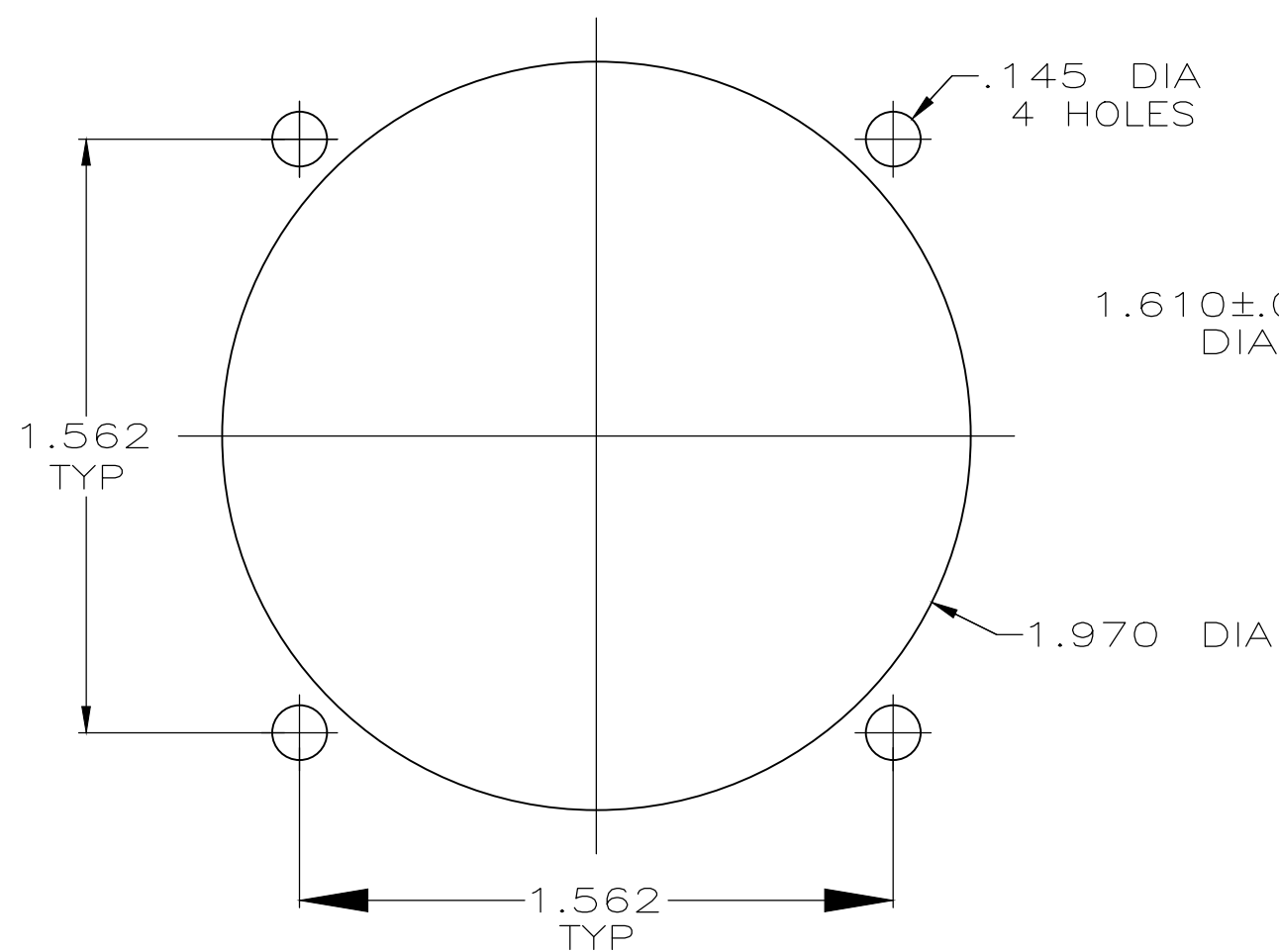

REAR MOUNTED PANEL CUTOUT

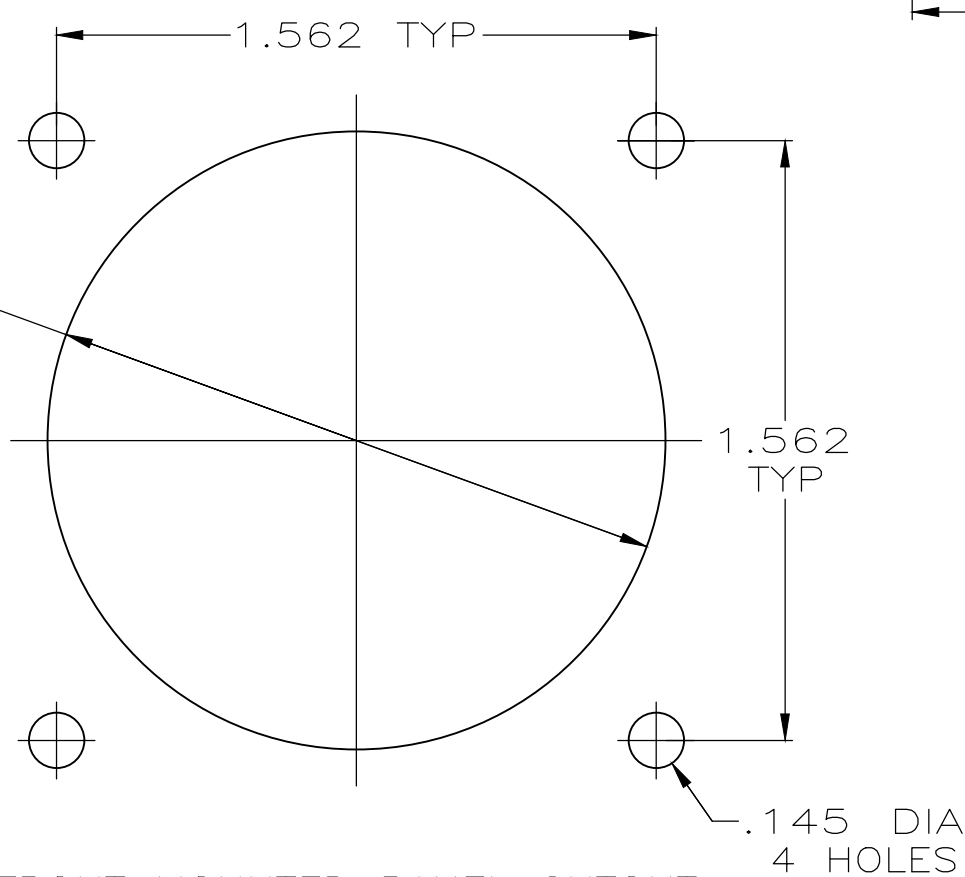

FRONT MOUNTED PANEL CUTOUT

OBSOLETE	YES	208459-2
	NO	208459-1
	PERIPHERAL SEAL	PART NUMBER

- 208459-1 MATES WITH AMP PLUG 208457-1 OR -3.
208459-2 MATES WITH 208457-1 ONLY.
- PART NUMBER AND DATE CODE MARKED ON ANY ANY FLANGE EDGE.

THIS DRAWING IS A CONTROLLED DOCUMENT.		DWN	R.LEE BG	6-22-91	TE Connectivity Ltd.
DIMENSIONS: INCHES		CHK	W.G.LENKER	4-15-92	
TOLERANCES UNLESS OTHERWISE SPECIFIED:		APVD	K.BEAVER	4-15-92	
0 PLC ± - 1 PLC ± - 2 PLC ± - 3 PLC ± .005 4 PLC ± - ANGLES ± -		PRODUCT SPEC	108-10040		
MATERIAL	-	FINISH	SEE CALLOUT	WEIGHT	0
		CUSTOMER DRAWING		SCALE	2:1
				SHEET	1 OF 1
				REV	L