

DVP-7642E/7651E

8/16-ch H.264 PCIe Video Capture Card with SDK

NEW

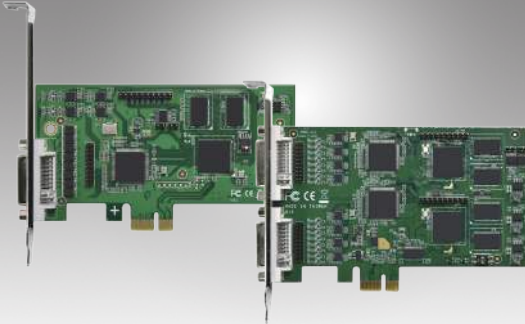

DVP 7642E

DVP-7651E

Features

- 8/16-channel composite video inputs with H.264 hardware compression
- 30/25fps (NTSC/PAL) at up to 4CIF resolution for each channel of display
- 30/25 fps (NTSC/PAL) at up to 4CIF / D1+CIF dual stream resolution for each channel of recording
- PCIe x 1 host interface
- Supports Watchdog function
- Windows/Linux OS supported



Introduction

DVP-7642E/DVP-7651E is a PCIe-bus, hardware compression video capture card with 8/16 analog video and 8/16 audio inputs. DVP-7642E/DVP-7651E series support H.264 compression format at up to 4CIF resolution at real-time frame rate (30/25fps) for each channel. With an easy-to-use software development kit (SDK) and flexibility to stack multiple cards, DVP-7642E/DVP-7651E series are ideal solutions for various video capture applications or video surveillance.

Specifications

Video	Video Standard	Composite for NTSC/PAL
	Video Input	8/16 x BNC connectors
	Compression	H/W H.264 Main Profile
	Max. Display Rate	30/25 fps (NTSC/PAL) @ 4CIF
	Max. Recording Rate	30/25 fps (NTSC/PAL) @ 4CIF+CIF dual stream/ch
Audio	Audio Input	8/16 x RCA
	Format	MONO/16 bits/8000HZ ~16000HZ
System Requirements	CPU (Display)	Intel Core 2 Duo E2200 2.2 GH
	CPU (Recording)	Intel Core 2 Duo E2200 2.2 GH
	Memory	2 GB
	VGA	1024 x 768, DirectX 9.0c
	Operating System	Windows XP/XPe/Vista/7; Linux 2.6.14 or higher; 32/64 bits
Physical Characteristics	Host Interface	PCIe x 1
	Operating Temperature	-20 ~ 70° C (-4 ~ 158° F)
	Storing Temperature	-40 ~ 85° C (-40 ~ 185° F)
	Dimensions	DVP-7642E: 122 x 69mm DVP-7651E: 132 x 85mm
	Safety	CE/FCC

Versatile SDK Support (For Windows Only)

Advantech provides software development kit (SDK), a set of development tools that allows a software engineer to integrate video capture modules into different types of system. Functions include video recording, playback and instant preview.

- Software Library
- SDK Manual
- Sample Program

Connection Diagram

DVP-7642E

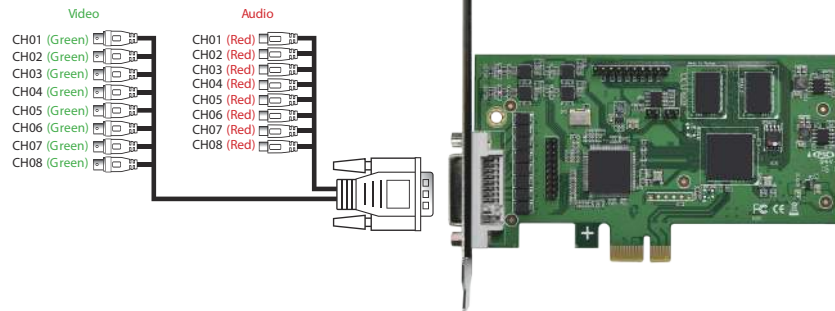

DVP-7651E

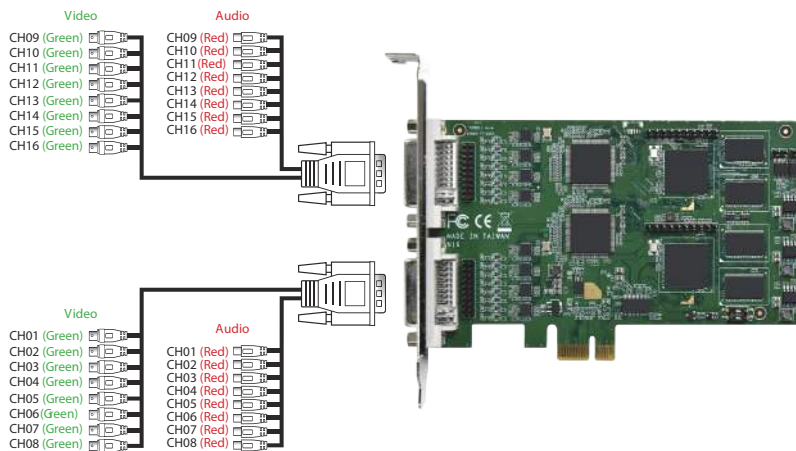

Ordering Information

Part Number	Description
DVP-7642E	8-ch H.264 PCIe Video Capture Card with SDK
DVP-7651E	16-ch H.264 PCIe Video Capture Card with SDK

Packing List

Item	Amount
DVP-7642E/DVP-7651E Capture Card	1 (piece)
Audio/Video cable (DVI-I male header)	1(7642E) (piece) 2(7651E) (piece)
Watchdog Cable (Option)	1 (piece)