

REVISIONS					
P	LTR	DESCRIPTION	DATE	DWN	APVD
E		ECR-21-122896	02DEC2021	LS	MP
E1		ECR-22-129065	09FEB2022	LS	MP
F		ECR-22-131292	03MAR2022	LS	MP
F1		ECR-22-140111	24MAY2022	LS	MP

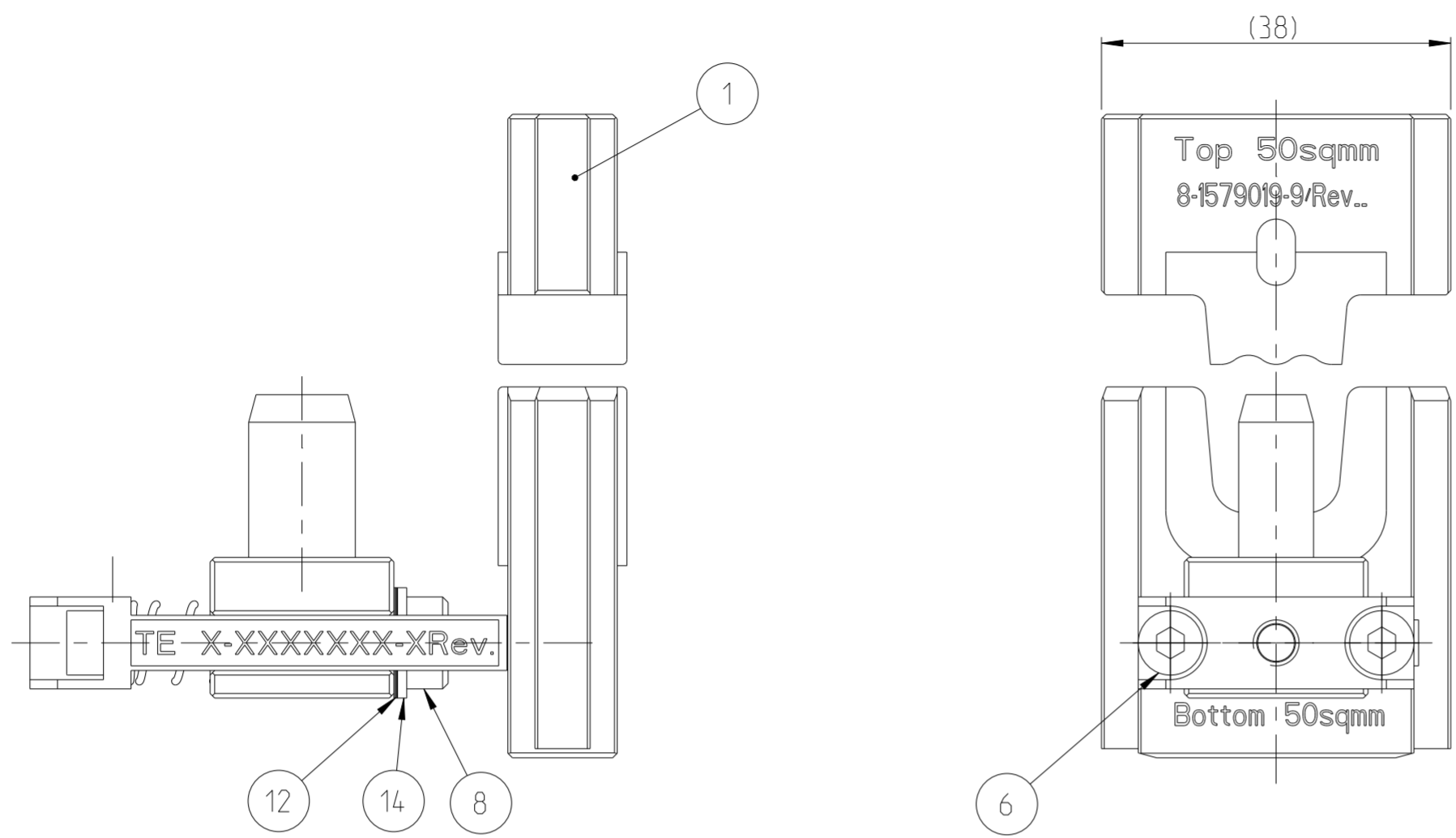

TERMINAL NAME	RING TONGUE, 50 SQ MM / M8 - INTERCABLE
TE TERMINAL PART NUMBER(S)	3-2177380-1 / 3-2177380-2 (INTERCABLE)
APPLICATION SPECIFICATION	114-94133 / VW TAB 016.358.AC
REFERENCE DRAWING	-
USED ON	528008-4 (HV CRIMPING MACHINE) - OBSOLETE WITH 541868-2 (ADAPTER) △1
INSTRUCTION SHEET	-

CABLE SUPPLIER/SPECIFICATION	CABLE SIZE	CRIMP HEIGHT	CRIMP HEIGHT REFERENCE SETTING
COROPLAST - FHLR2GCB2G/A12	50mm2	7.4 ±0.1	-

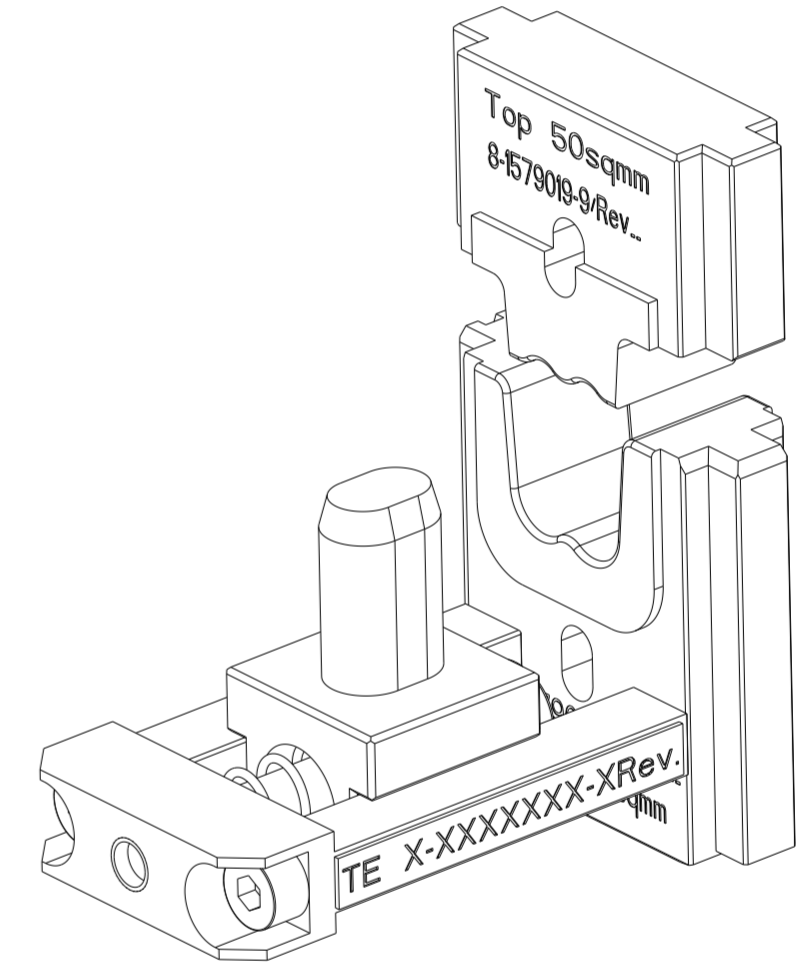

1	519115-4	A	WASHER, SHIM RING, 1.0 THICK	14
4	519035-4	O	WASHER, SHIM RING, 0.1 THICK	12
1	2-22282-0	D	SPRING, COMPRESSION	10
1	519152-6	A	FITTING SCREW	8
2	1-519072-4	O	SCREW, CAP, SOCKET HD, METRIC	6
1	6-519709-3	E	LOCATOR IPT-VW	4
1	519579-7	C	BAY IPT-VW	3
1	8-1579019-9	A	DIE SET IPT-VW WIRE, 50SQ.MM	1
QTY	PART NO	REV	DESCRIPTION	ITEM NO

△1 ALTERNATIVE COMPONENTS FOR USING HV20, TCPN 2348822:
 1x 2326383-1 (BASE PLATE ASSEMBLY)
 1x 2234755-1 (ADAPTOR ASSY, FOR 528041, HV-20T)
 1x 541868-1 (HV- CM DIE-SET ADAPTER)

△2 AS AN OPTION:
 ITEM 4 - LOCATOR IPT, CAN BE EXCHANGE BY TCPN 1-2234151-4 TO USE OTHER RING TONGUE TERMINAL WITH INTERCALE ORDER NO. 1012483.
 CRIMP SPECIFICATIONS REMAIN IN PLACE.
 LOCATOR MUST BE ORDER SEPARATELY.

THIS DRAWING IS A CONTROLLED DOCUMENT.		DWN R.GERMANN 25MAY12	STE TE Connectivity	
DIMENSIONS: mm		CHK G.STEGMAYER 25MAY12		
TOLERANCES UNLESS OTHERWISE SPECIFIED:		APVD G.STEGMAYER 25MAY12	NAME DIE SET IPT- VW, 50SQ.MM	
0 PLC ±		PRODUCT SPEC	SIZE CAGE CODE DRAWING NO RESTRICTED TO	
1 PLC ±		APPLICATION SPEC	A2 00779 C-528041-7	
2 PLC ±		WEIGHT	SCALE 3:2 SHEET 1 OF 1 REV F1	
3 PLC ±		CUSTOMER DRAWING		
4 PLC ±				
ANGLES ±				
FINISH				