

QUICK START GUIDE FOR DEMONSTRATION CIRCUIT 661 PHOTOFLASH CAPACITOR CHARGER, HIGH VOLTAGE SUPPLY

LT3468ES5/LT3468ES5-1

DESCRIPTION

Demonstration circuit 661 is a DC/DC flyback converter using the highly integrated LT®3468ES5/LT®3468ES5-1 to rapidly charge a photoflash capacitor up to 320V for photoflash applications. It demonstrates a simple application circuit operating in high efficiency and shows appropriate layout techniques for the LT3468ES5/LT3468ES5-1. The circuit uses small surface mount components and has very small board space compared to conventional solutions.

This demonstration circuit is particularly useful for applications such as camera flash, PDA and cell phone flash and high voltage power supplies that require high efficiency and extremely small size.

Design files for this circuit board are available. Call the LTC factory.

LT is a trademark of Linear Technology Corporation

Table 1. Demo Board Assembly Versions

ASSEMBLY VERSIONS	U1	I _{SW-PK} (PEAK SWITCH CURRENT LIMIT)
DC661A-A	LT3468ES5	1.4A
DC661A-B	LT3468ES5-1	0.6A

QUICK START PROCEDURE

Demonstration circuit 661 is easy to set up to evaluate the performance of the LT3468ES5/LT3468ES5-1. Refer to Figure 1 for proper measurement equipment setup and follow the procedure below:

NOTE: When measuring the input or output voltage ripple, care must be taken to avoid a long ground lead on the oscilloscope probe. Measure the input or output voltage ripple by touching the probe tip directly across the Vin or Vout and Gnd terminals. See Figure 2 for proper scope probe technique

NOTE: For safe operation, always shield the circuit when power is on, and always discharge the high voltage output capacitor after power is off.

1. With power off, connect input power source Vin to the Vin and Gnd terminals. Input voltage is limited to 2.5V to 8V.

2. Connect second power source Vcharge to the Charge and Gnd terminal. Input voltage is limited to 2.5V to 8V.

3. Connect load (a 220uF, 350V photoflash capacitor) between the +STROBE CAP and -STROBE CAP terminals.

4. Slowly turn on power source Vin. Turn Vcharge on to enable charge operation. Check for the proper output voltages. Vout= 320V

NOTE: If there is no output, temporarily disconnect the load and make sure that Vcharge is applied to Charge terminal.

5. For single source operation, connect Charge terminal to Vin through an on/off switch. Turn on the switch to enable charge operation.

Warning: Operate by high voltage trained personnel only.

QUICK START GUIDE FOR DEMONSTRATION CIRCUIT 661 PHOTOFLASH CAPACITOR CHARGER, HIGH VOLTAGE SUPPLY

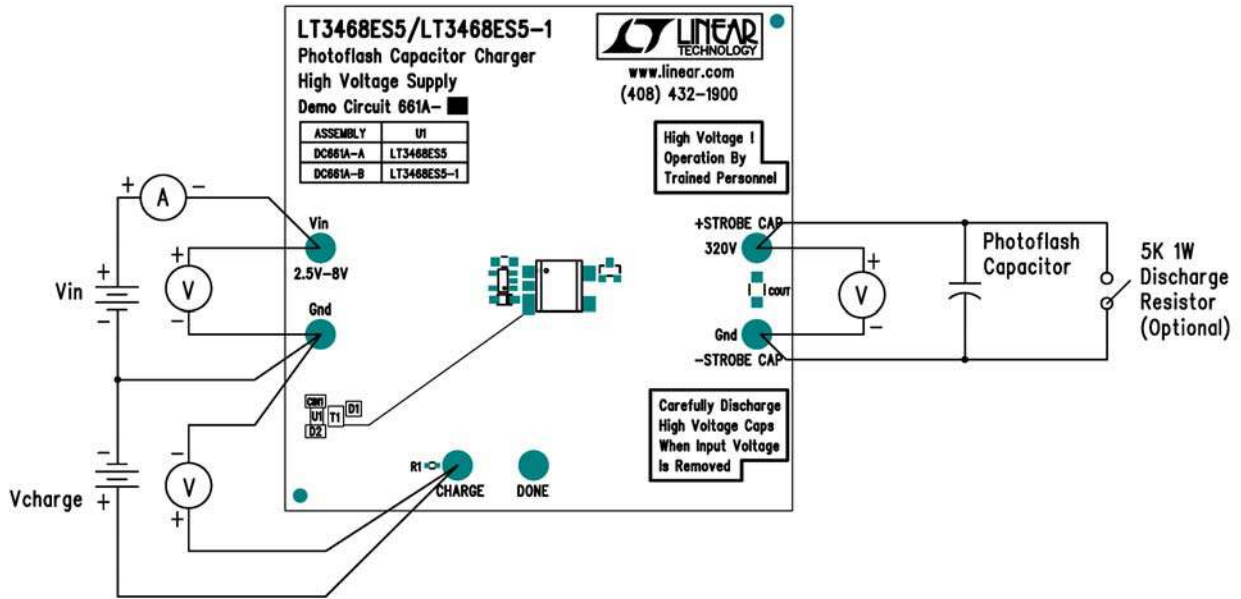

Figure 1. Proper Measurement Equipment Setup

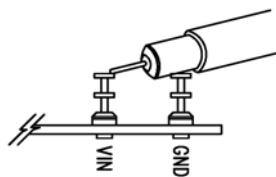
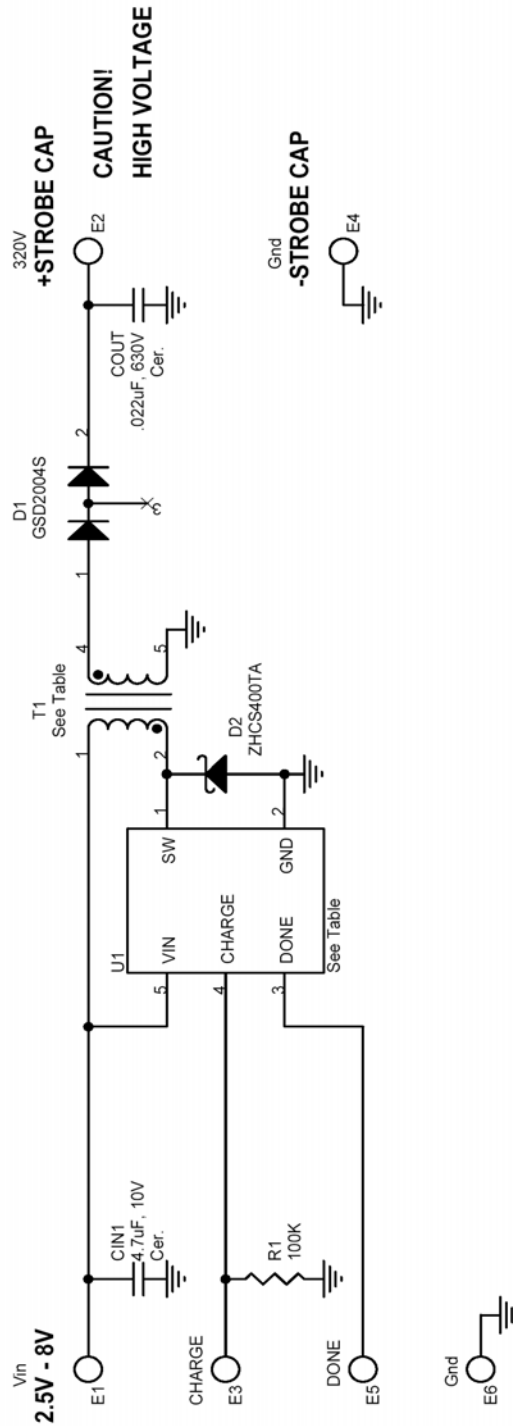

Figure 2. Scope Probe Placement for Measuring Input or Output Ripple

QUICK START GUIDE FOR DEMONSTRATION CIRCUIT 661 PHOTOFLASH CAPACITOR CHARGER, HIGH VOLTAGE SUPPLY

NOTES: UNLESS OTHERWISE SPECIFIED



LINEAR TECHNOLOGY CORPORATION
 1630 McCARTHY BLVD.
 MILPITAS, CA, 95035
 408-432-1900
 408-434-0507 FAX

TABLE

ASSEMBLY	U1	T1
DC661A-A	LT3468ES5	SBL-5.6-1
DC661A-B	LT3468ES5-1	SBL-5.6S-1

Title Photoflash Capacitor Charger High Voltage Supply		
Size DC661A-A & A-B	Document Number LT3468ES5/LT3468ES5-1	Rev
Date: Thursday, October 16, 2003	Sheet 1	of 1