

# ICL88xx

## Datasheet for ICL8800, ICL8810 and ICL8820

### Features

The ICL88xx family of single stage flyback controllers for constant voltage output is tailored for LED lighting applications to meet the required performance. They offer power factor correction (PFC) and low total harmonic distortion (THD) from low to full load conditions.

#### General features ICL8800, ICL8810, ICL8820

- Constant voltage (CV) output flyback topology with a feature set and operation targeting lighting applications
- Optimized for high power factor (HPF) flyback topology with secondary side regulation (SSR) operation, primary side regulation (PSR) possible
- Supports universal input voltage (90  $V_{AC}$  to 300  $V_{AC}$ , 45 Hz to 66 Hz) and DC input voltage operation
- High power factor and low THD, across wide AC input voltage and output load range
- Quasi-resonant mode (QRM) operation with continuous conduction mode (CCM)-prevention and valley switching discontinuous conduction mode (DCM) in mid to light load
- Adjustable on-time mapping at valley changing position, for the desired maximum operating switching frequency
- Adjustable maximum on-time – limits input power and current allowing safe-operation under low line condition
- Comprehensive set of protections:
  - internal overtemperature protection (OTP)
  - flyback output overvoltage protection (OVP)
  - primary side overcurrent protection (OCP)
  - brownin protection
  - brownout protection
  - $V_{CC}$  overvoltage protection
  - open loop protection
  - input overvoltage protection
- Soft start to reduce component stress during turn-on
- External start-up circuit control signal
- Reduced gate driver voltage during start-up sequence, to allow smaller  $V_{CC}$  capacitance for faster start-up

#### Additional features ICL8810, ICL8820

- Burst mode for very light loads and low system standby power consumption
- $V_{CC}$  wake-up burst operation, to maintain sufficient  $V_{VCC}$  in burst mode
- Reduced gate driver voltage in burst mode, to reduce gate charge loss, for lower standby power

#### Additional features ICL8820

- Jitter function for DC input, to ease electromagnetic interference (EMI) test compliance for emergency lighting

### Potential applications

#### HPF flyback CV

- Tailored for LED driver application
- Also suited for adapter, charger, ceiling fan, flat TV, all-in-one PC, monitor applications

**Product validation**

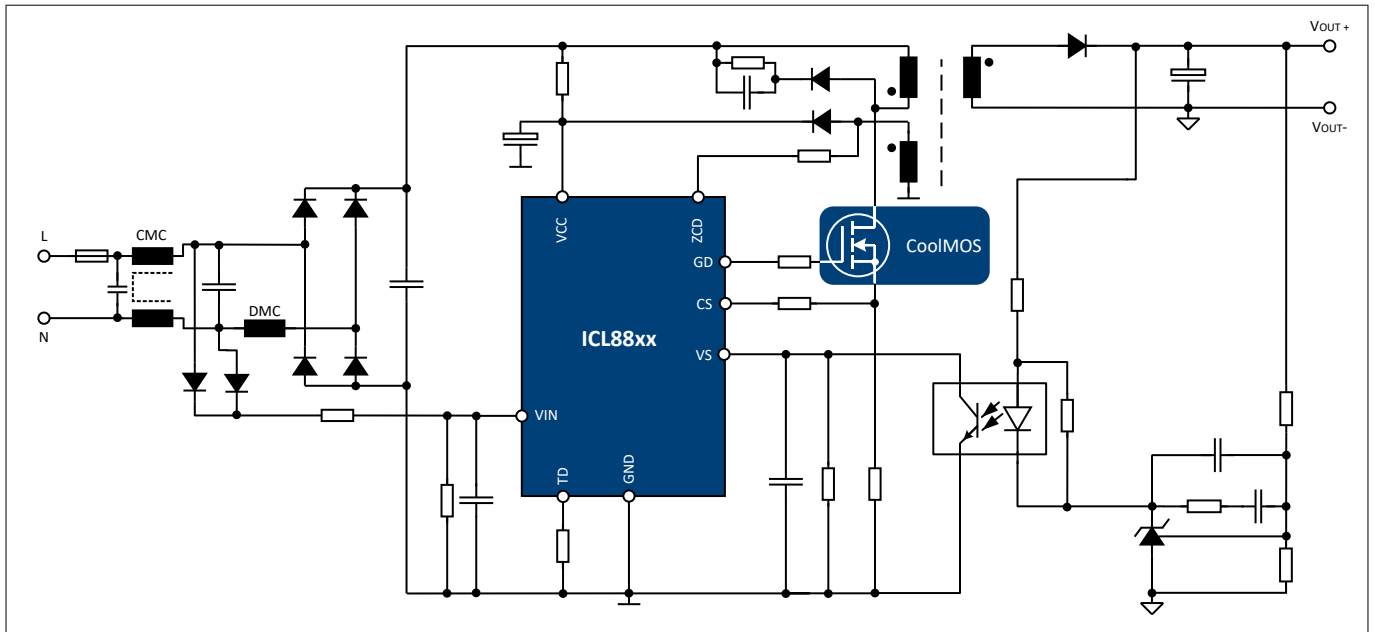

**Figure 1** Flyback-SSR-CV

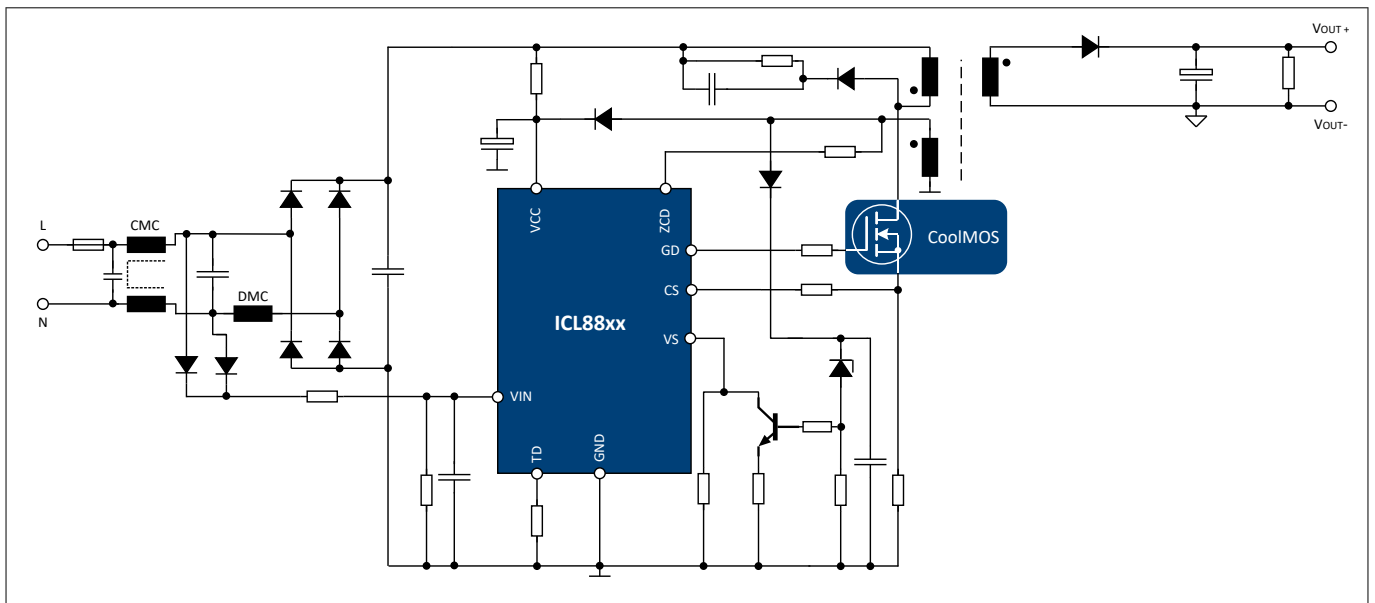

**Figure 2** Flyback-PSR-CV

Product type	Package	Marking	Ordering code
ICL8800	PG-DSO-8	L8800	SP003135776
ICL8810	PG-DSO-8	L8810	SP005418406
ICL8820	PG-DSO-8	L8820	SP005418407

**Product validation**

Qualified for applications listed above based on the test conditions in the relevant tests of JEDEC20/22.

**Description**

## **Description**

The ICL88xx is a voltage mode controller for flyback topologies operating in QRM and valley switching DCM. It is designed for low and high power lumen LED driver, requiring high power factor and efficiency. The flyback controller is capable of controlling SSR-CV and PSR-CV topologies. Offering a wide usage in low cost applications where a PFC functionality in dual stage topologies is required.

For lighting applications, the IC offers a wide power range as well as a comprehensive set of protections, including a power limitation. The IC is easy to design in and requires a minimum number of external components.

The system performance and efficiency, especially in light load conditions, can be optimized using Infineon CoolMOS™ P7 power MOSFETs.

### **ICL8810 and ICL8820**

The integrated burst mode function allows designs with a very low standby power consumption during standby mode and very light loads.

### **ICL8820**

The jitter function eases the design of emergency lighting LED drivers without additional circuitry to improve EMI performance.

**Table of contents**

	<b>Table of contents</b> .....	4
<b>1</b>	<b>Pin configuration</b> .....	6
<b>2</b>	<b>Block diagram</b> .....	7
<b>3</b>	<b>Functional description</b> .....	8
3.1	Start-up .....	8
3.2	TD pin internal pull-up and external start-up circuit control .....	8
3.3	Input voltage detection and protection .....	9
3.4	ZCD pin signal sensing .....	9
3.5	Power factor correction and THD correction .....	11
3.6	VS pin signal sensing .....	12
3.7	Operating modes .....	13
3.8	Pulse generation .....	15
3.9	Primary side overcurrent protection .....	21
3.10	VCC voltage protections .....	22
3.11	Flyback output overvoltage protection .....	22
3.12	Overtemperature protection .....	23
3.13	Open loop protection .....	23
3.14	State flow chart and fault reaction .....	24
3.15	Adjustable functions .....	25
<b>4</b>	<b>Electrical characteristics and parameters</b> .....	26
4.1	Absolute maximum ratings .....	26
4.2	Operating conditions .....	27
4.3	DC electrical characteristics .....	27
4.3.1	Power supply .....	27
4.3.2	Zero crossing detection .....	28
4.3.3	Voltage sense .....	28
4.3.4	Input voltage detection .....	28
4.3.5	TD configuration .....	29
4.3.6	Current sense .....	29
4.3.7	PWM generation .....	30
4.3.8	Gate driver .....	30
4.3.9	Clock oscillators .....	30
4.3.10	Temperature sensor .....	30
<b>5</b>	<b>Package dimensions</b> .....	31
<b>6</b>	<b>Glossary</b> .....	33
<b>7</b>	<b>Revision history</b> .....	34



**Table of contents**

**Disclaimer** ..... 36

1 Pin configuration

1 Pin configuration

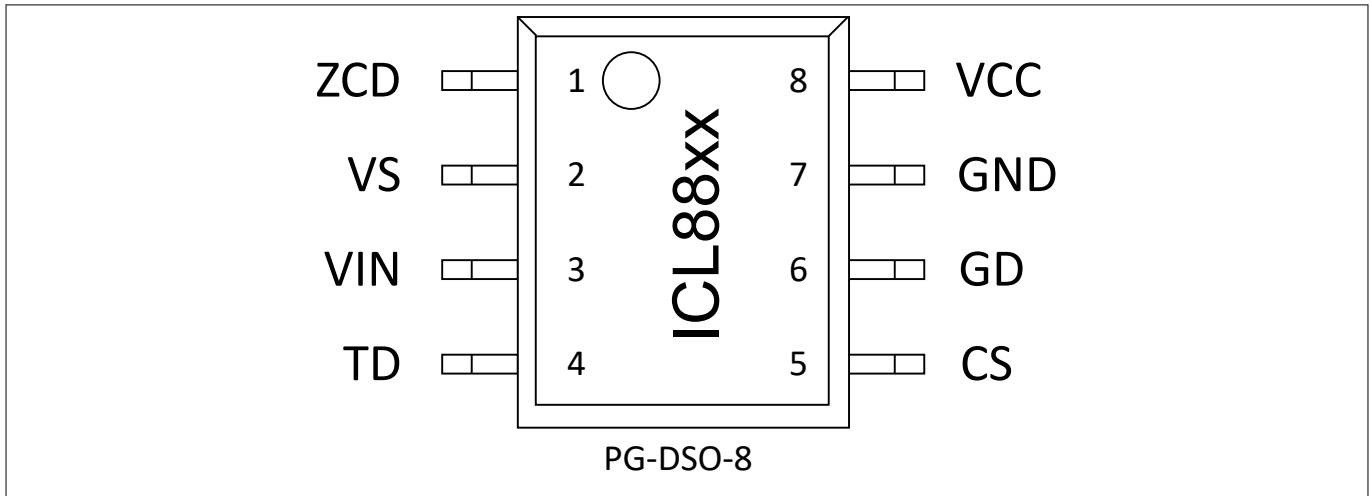

Figure 3 Pin configuration

Table 1 Pin definition and function

Symbol	Pin	Function
ZCD	1	<b>Zero crossing detection</b> This pin is connected to an auxiliary winding via a series resistor to detect the zero crossing, for QRM valley switching. This series resistor value can be adjusted to configure the on-time mapping and maximum on-time.
VS	2	<b>Feedback sensing</b> This pin measures the feedback signal in the form of load current, for output regulation with voltage mode control.
VIN	3	<b>Input voltage detection</b> This pin is used to detect AC or DC input for frequency jitter function, and measure the rectified input voltage via a resistor divider for the power limitation function, brownin, brownout and input overvoltage protection.
TD	4	<b>THD correction</b> The resistance to ground $R_{TD}$ of this pin adjusts the THD correction gain and the turn-on delay upon zero crossing detection for QRM valley switching. The internal pull-up of this pin can also be used to control an external start-up circuit for active $V_{CC}$ charging.
CS	5	<b>MOSFET current sense and flyback output overvoltage protection</b> This pin is used for primary side overcurrent protection. The series resistance (connected between this pin and the primary MOSFET current shunt resistor) can be used to adjust the flyback output over-voltage protection level.
GD	6	<b>Gate driver</b> This pin controls the gate of the MOSFET.
GND	7	<b>Ground</b> This pin is connected to ground and represents the ground level of the IC for the supply voltage, gate driver and sense signals.
VCC	8	<b>Operating voltage supply</b> This pin supplies the IC.

2 Block diagram

2 Block diagram

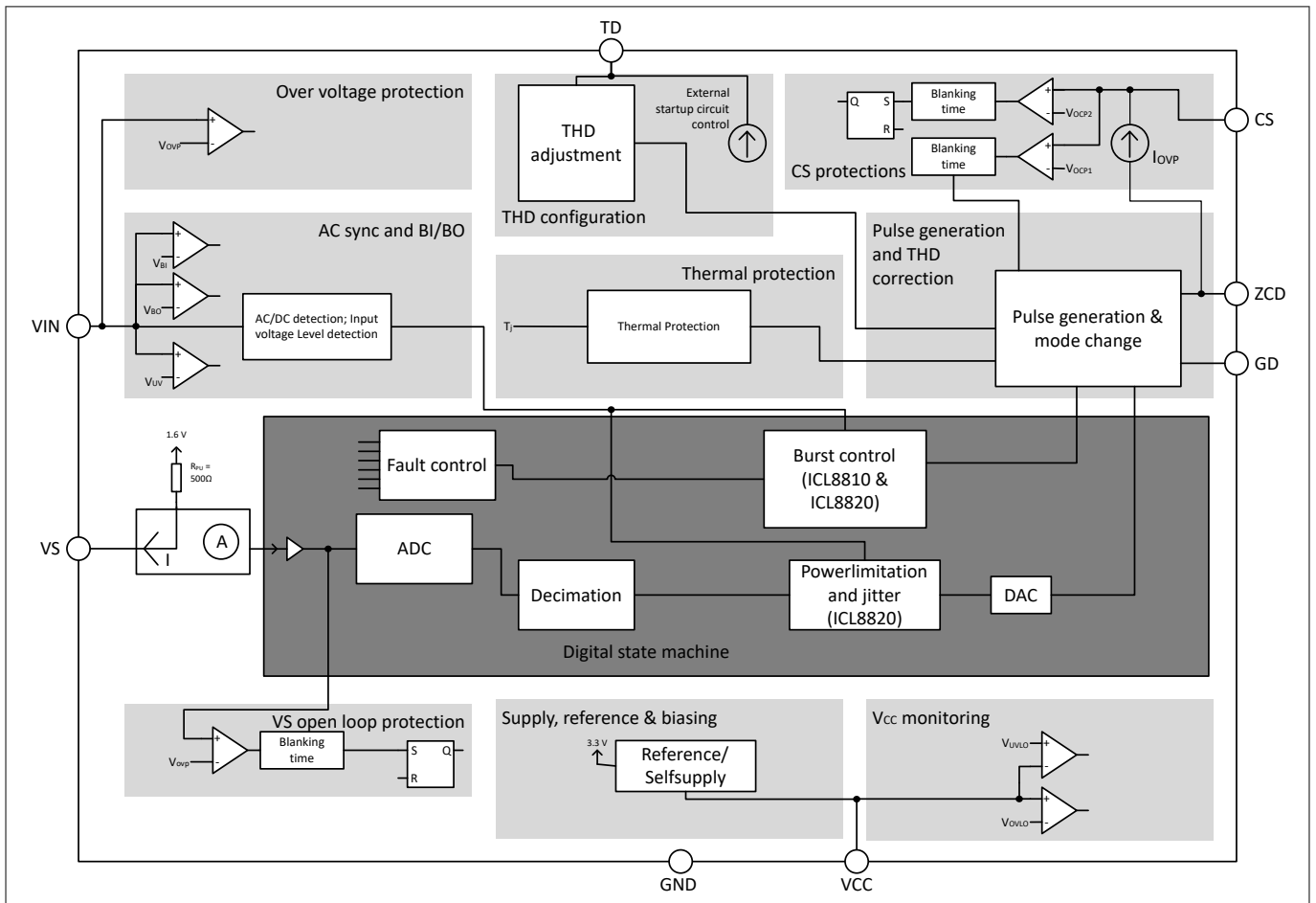

Figure 4 Block diagram

3 Functional description

3 Functional description

These sections describe the listed functions in detail.

3.1 Start-up

In the pre-start-up phase, ICL88xx measures the TD pin resistance to ground  $R_{TD}$ , the average VIN pin voltage  $V_{VIN,avg}$ , and its internal junction temperature  $T_j$ . If the conditions for start-up are met, ICL88xx initiates a soft start, to reduce the component stress during start-up.

After the soft start is completed without any protection triggering, ICL88xx enters the RUN state for output regulation based on VS pin signal sensing.

Note: The reduced gate driver voltage  $V_{GDred}$  (7 V typ.) is applied during start-up.

3.2 TD pin internal pull-up and external start-up circuit control

Apart from charging the  $V_{VCC}$  from the HV bus voltage via the current limiting resistor in Figure 1 and Figure 2, ICL88xx TD pin also supports the control of an exemplary external start-up circuit in Figure 5 for active  $V_{VCC}$  charging, with the following typical start-up sequence:

1. When ICL88xx is in the undervoltage lockout (UVLO) state and  $V_{VCC} < V_{VCCon}$  (12.5 V typ.), the TD pin internal pull-up is disabled.
2.  $V_{VCC}$  is charged to  $V_{VCCon}$  by the external start-up circuit, to activate ICL88xx.
3. In the pre-start-up phase, ICL88xx enables the TD pin internal pull-up resistor of  $R_{TD,RUN}$  (10 kΩ typ.) and  $R_{TD,flyback}$  (40 kΩ typ.) sequentially, to measure the TD pin resistance to ground of  $R_{TD}$ .
4. If the start-up conditions are met and the start-up is successful,  $R_{TD,RUN}$  is enabled in the soft start phase and in RUN state, to disable the external start-up circuit from charging the  $V_{VCC}$ . If any protection is triggered, ICL88xx enters UVLO state (returns sequence number 1) after a restart timer is expired.

Note: The internal voltage reference for the TD pin internal pull-up,  $V_{REF}$  is typically 3.3 V.

Note: For ICL8810 and ICL8820,  $R_{TD,RUN}$  is disabled in burst mode when VCC drops to  $V_{VCCwake}$  (7.6 V typ.), to allow the external start-up circuit to charge  $V_{VCC}$  to  $V_{VCCburst}$  (8.1 V typ.).

Figure 5 shows the equation for  $R_{TD}$  calculation when the exemplary start-up circuit is connected to the TD pin. The  $R_{TD}$  detected in the pre-start-up phase must be designed to be at least 27 kΩ when TD pin is internally pulled up by  $R_{TD,RUN}$ , and not more than 68 kΩ when TD pin is internally pulled up by  $R_{TD,flyback}$ . The is to activate the VS pin load current sensing for output regulation and stay within the TD configuration limit.

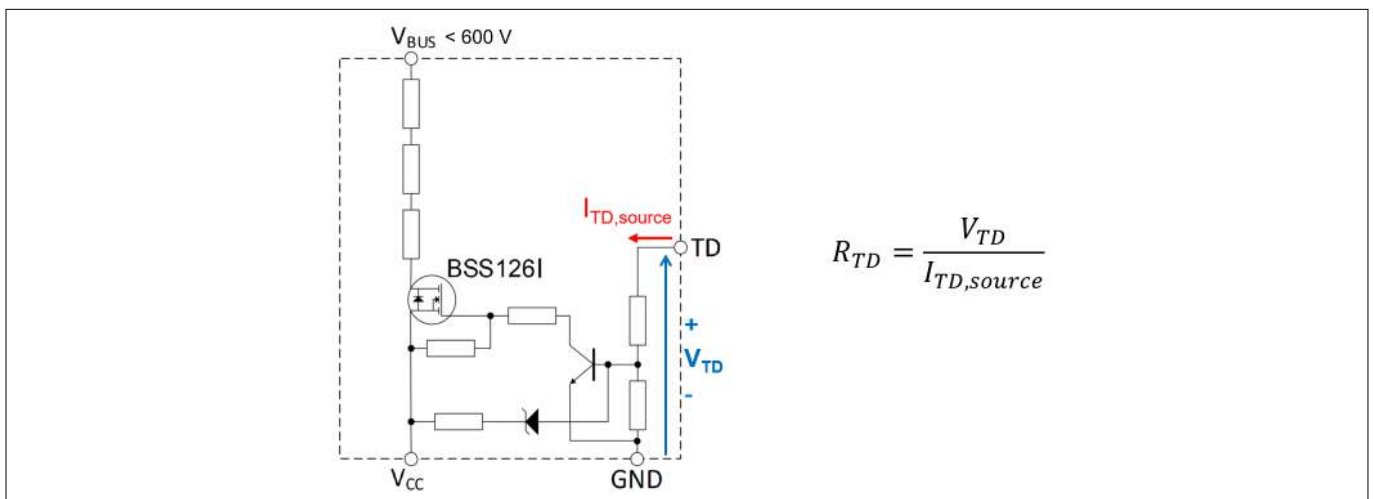

Figure 5 Exemplary external start-up circuit for active  $V_{VCC}$  charging, and  $R_{TD}$  generic equation



3 Functional description

3.3 Input voltage detection and protection

ICL88xx detects the AC or DC amplitude based on the ADC sampling of the  $V_{IN}$  pin voltage. For the power limiting function, brownin and brownout protections, the controller measures the average  $V_{IN}$  pin voltage  $V_{VIN,avg}$  based on the middle value of the highest  $V_{IN}$  pin voltage sample and the lowest  $V_{IN}$  pin voltage sample within an observation time. The observation time in RUN state is around 10.6 ms and 12.7 ms, based on the last synced AC line frequency of 50 Hz and 60 Hz, respectively.

*Note: In case of non-line-syncing, the observation time is around 10.6 ms. For example, non-line-syncing can happen when the system is started up with a DC input.*

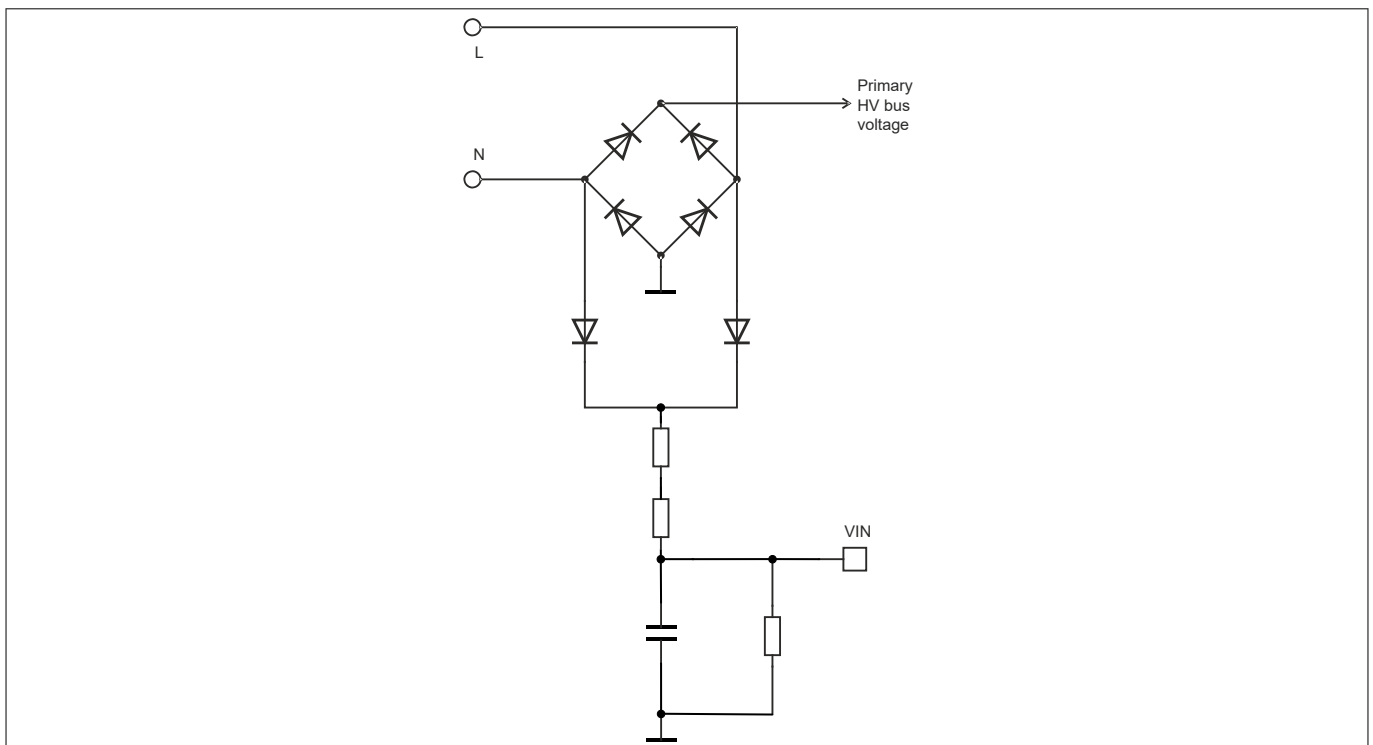

Figure 6  $V_{IN}$  pin circuit

In addition, the ICL88xx  $V_{IN}$  pin has an input overvoltage threshold of  $V_{VINOv}$  (2.0 V typ.) and a short protection with a threshold of  $V_{VINshort}$  (200 mV typ.).

During operation, if a sampled  $V_{IN}$  pin voltage  $V_{VIN} < V_{VINshort}$  is detected for more than a blanking time, the  $V_{IN}$  pin short protection is triggered. If the  $V_{VIN} < V_{VINshort}$  condition remains after the  $V_{IN}$  pin short protection restart time of  $t_{restart}$  (200 ms typ.), the brownin protection is triggered based on  $V_{VIN,avg} < V_{BI}$  detection instead. This leads to a fast restart cycle of  $t_{restart,fast}$  (25 ms typ.) afterwards.

By pulling down the  $V_{IN}$  pin signal to a level that triggers the  $V_{IN}$  pin short protection or brownout protection, ICL88xx gate pulse generation can be disabled and the controller current consumption can be lowered.

3.4 ZCD pin signal sensing

ICL88xx  $ZCD$  pin detects the auxiliary winding voltage zero-crossing via a  $ZCD$  series resistor of  $R_{ZCD}$  connected to the winding. A zero-crossing is detected with the hysteresis of  $V_{ZCDUp}$  (55 mV typ.) and  $V_{ZCDDown}$  (45 mV typ.) thresholds.

In QRM, ICL88xx counts the number of zero crossings until the target number is reached, and switches on at the valley to minimize the switching loss. If the target number is not reached and further zero crossing signals are not detectable via  $ZCD$  pin, zero crossing events can be generated internally by extrapolation. Figure 7 shows an example of the 1<sup>st</sup> zero crossing detection and the 1<sup>st</sup> valley switching in QRM operation.

3 Functional description

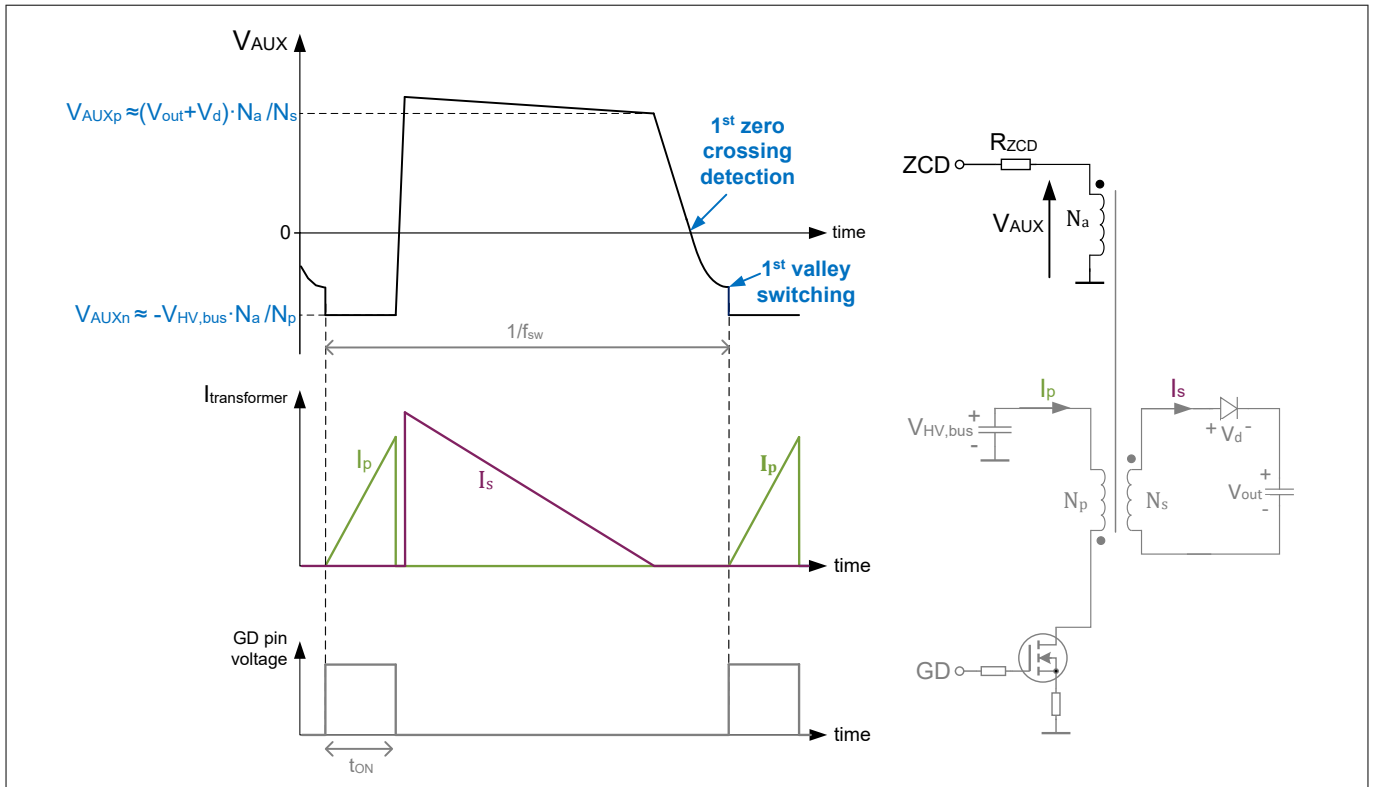

**Figure 7 Exemplary waveform of QRM operation with 1<sup>st</sup> zero crossing detection and 1<sup>st</sup> valley switching**

$R_{ZCD}$  limits the ZCD pin sink and source currents when the auxiliary winding voltage exceeds the ZCD pin internal clamping levels  $V_{ZCDpclp}$  (0.55 V typ.) and  $V_{ZCDnclp}$  (-0.5 V typ.), respectively. When the sensed voltage level of the auxiliary winding is not sufficient (for example, during start-up), an internal start-up timer initiates a new cycle every  $t_{Rep}$  (52  $\mu$ s typ.) after turn-off of the gate driver. From the ZCD pin sink and source currents, ICL88xx detects the ZCD pin positive peak settled clamping current  $I_{ZCDpclp}$  and negative peak settled clamping current  $I_{ZCDnclp}$ , for its internal operations, such as THD correction and flyback output overvoltage protection.

$$I_{ZCDpclp} = \frac{V_{AUXp} - V_{ZCDpclp}}{R_{ZCD}}$$

**Equation 1**

$$I_{ZCDnclp} = \frac{|V_{AUXn}| - |V_{ZCDnclp}|}{R_{ZCD}}$$

**Equation 2**

Where  $V_{AUXp}$  and  $V_{AUXn}$  are the positive peak and negative peak values, respectively, of the settled auxiliary winding voltages, as shown in Figure 7.

In addition, ICL88xx derives the ZCD pin peak to peak settled clamping current  $I_{ZCDclp}$  based on the sum of  $I_{ZCDpclp}$  and  $I_{ZCDnclp}$ , for its internal operations, such as pulse generation and power limitation.

$$I_{ZCDclp} = I_{ZCDpclp} + I_{ZCDnclp}$$

**Equation 3**

3 Functional description

3.5 Power factor correction and THD correction

In RUN state, ICL88xx achieves power factor correction, when the VS pin feedback signal maps to a stable operating point in QRM. Additionally, ICL88xx THD correction function extends the on-time, especially when it is near AC input voltage zero crossing, to optimize the AC input current waveform.

As shown in Figure 8 area A, ICL88xx increases the on-time extension near AC input voltage zero crossing, where  $I_{ZCDnclp}$  is less than 80% of  $I_{ZCDpclp}$ .

The gain of the THD correction on-time extension is configurable based on the detected TD pin resistance to ground  $R_{TD}$  in the pre-start-up phase. Since the THD correction on-time extension also affects the turn-on delay upon zero crossing detection, the  $R_{TD}$  value has to be fine-tuned manually for a given system, to achieve a balance between the QRM valley switching point optimization and THD correction.

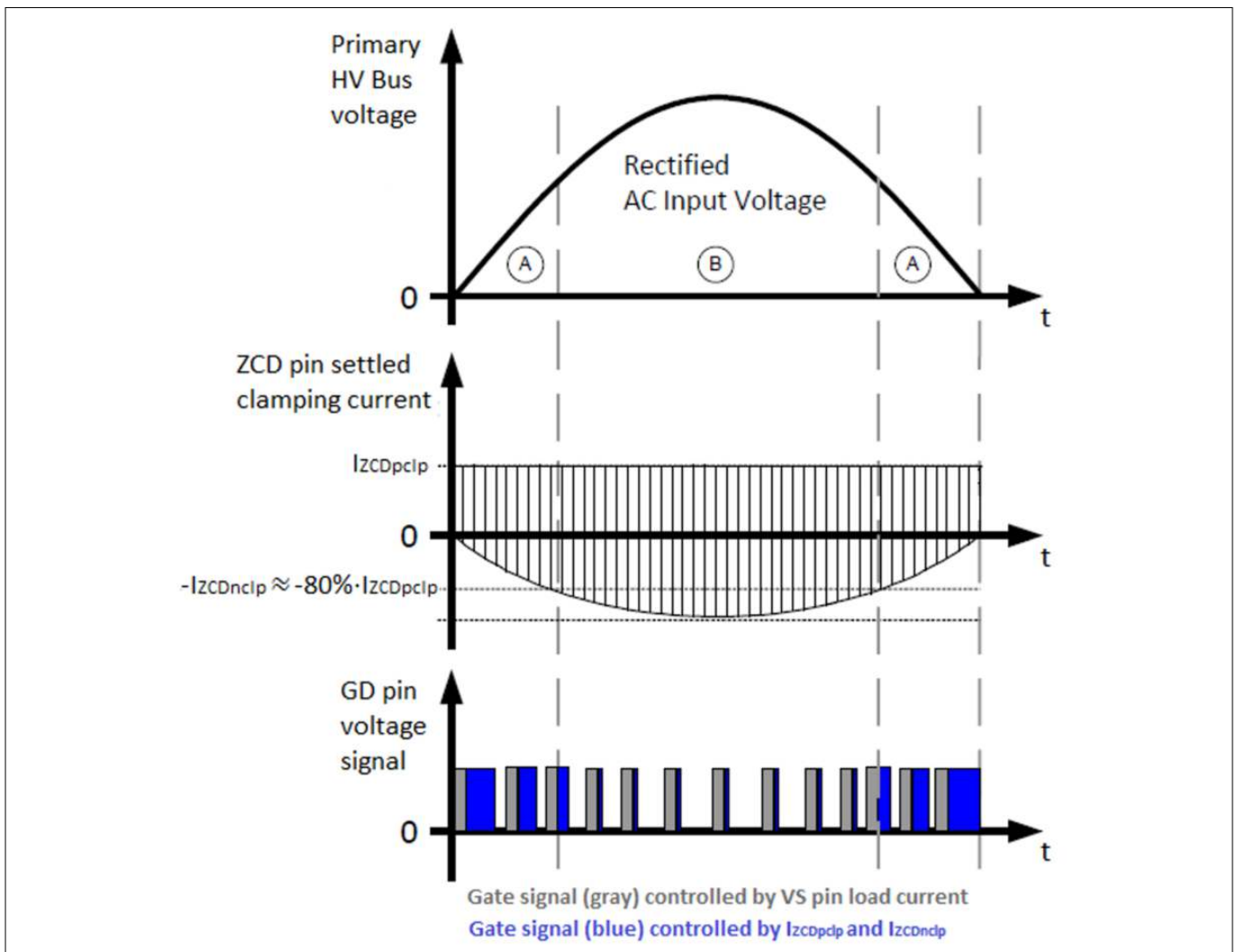

Figure 8 ICL88xx THD correction with on-time extension near AC input voltage zero crossing

If the TD pin is only used for THD correction gain configuration, but not for other purpose like controlling an external start-up circuit, a resistor can be connected from TD pin to ground, and simply fine-tuned between 27 kΩ and 68 kΩ.

If there is any circuit more than just a resistor connected between TD pin and ground, the following generic equation for  $R_{TD}$  calculation is applied:

$$R_{TD} = \frac{V_{TD}}{I_{source, TD}}$$

Equation 4

**3 Functional description**

Where  $V_{TD}$  is the  $TD$  pin voltage with reference to ground and  $I_{source,TD}$  is the current flowing out of  $TD$  pin, when the internal pull-up resistor of  $R_{TD,RUN}$  or  $R_{TD,flyback}$  is enabled in the pre-start-up phase.

The minimum  $R_{TD}$  value for  $TD$  configuration and to activate the  $VS$  pin load current sensing for output regulation in  $RUN$  state is  $27\text{ k}\Omega$ , when  $TD$  pin is internally pulled up by  $R_{TD,RUN}$  in the pre-start-up phase.

The maximum  $R_{TD}$  value for  $TD$  configuration is  $68\text{ k}\Omega$ , when  $TD$  pin is internally pulled up by  $R_{TD,flyback}$  in the pre-start-up phase.

**3.6 VS pin signal sensing**

In  $RUN$  state, ICL88xx measures the feedback signal for output regulation based on the ADC sampling of the  $VS$  pin load current. When operating in  $QRM$  with AC input, ICL88xx also synchronizes some of its operation to the line frequency or AC half cycle, when the  $VS$  pin load current ripple is large enough.

To activate the  $VS$  pin load current sensing for output regulation in  $RUN$  state, a  $12\text{ k}\Omega$  resistor must be connected from the  $VS$  pin to ground, and  $R_{TD}$  must be at least  $27\text{ k}\Omega$  when  $TD$  pin is internally pulled up by  $R_{TD,RUN}$  in the pre-start-up phase.

For secondary side regulation, the  $VS$  pin load current consists of the current flowing through the opto coupler and the  $12\text{ k}\Omega$  resistor. When the  $VS$  pin load current is  $-I_{VSADCmin}$  ( $210\text{ }\mu\text{A}$  typ.) or less, the power transfer is maximum. When the  $VS$  pin load current is  $-I_{VSADCmax}$  ( $610\text{ }\mu\text{A}$  typ.) or more, the power transfer is minimum.

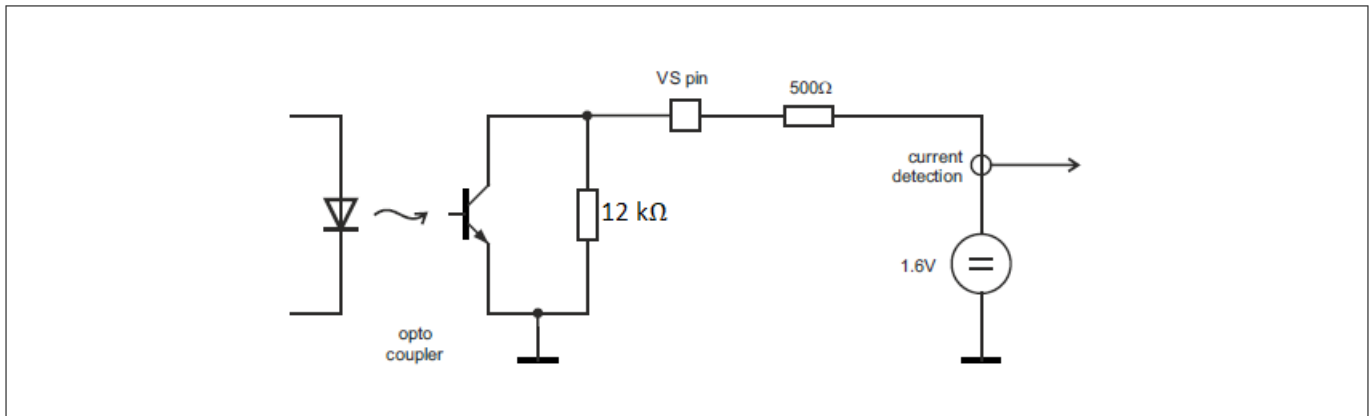

**Figure 9 VS pin load current sensing based on secondary side regulation**

3 Functional description

3.7 Operating modes

In RUN state, ICL88xx operates in either QRM or burst mode. Burst mode applies to ICL8810 and ICL8820 only.

Quasi-resonant mode (QRM)

QRM maximizes the efficiency and minimizes the EMI by turning on the power switch at the drain voltage valley. ICL88xx controls the on-time and valley number in QRM. When the valley number changes, the controller compensates the QRM on-time to achieve a relatively constant power transfer for a smooth transition.

Figure 10 areas highlighted in blue show the on-time compensation effect (in zig-zag pattern) when, for example, the QRM valley number is increased from 1 to 2, from 2 to 3, and from 3 to 4. When the relative power is further decreased, the on-time compensation continues at higher valley changing position (in smaller zig-zag), until it reaches the maximum valley number of 32. To ensure the QRM switching frequency reduction stays above the audible range, the QRM off-time is limited to a maximum value of  $t_{off}$  (47  $\mu s$  typ.).

Increasing the ICL88xx valley number ensures that the system-dependent QRM remains below a certain limit, to achieve a high efficiency and low EMI spectrum over a wide operating range.

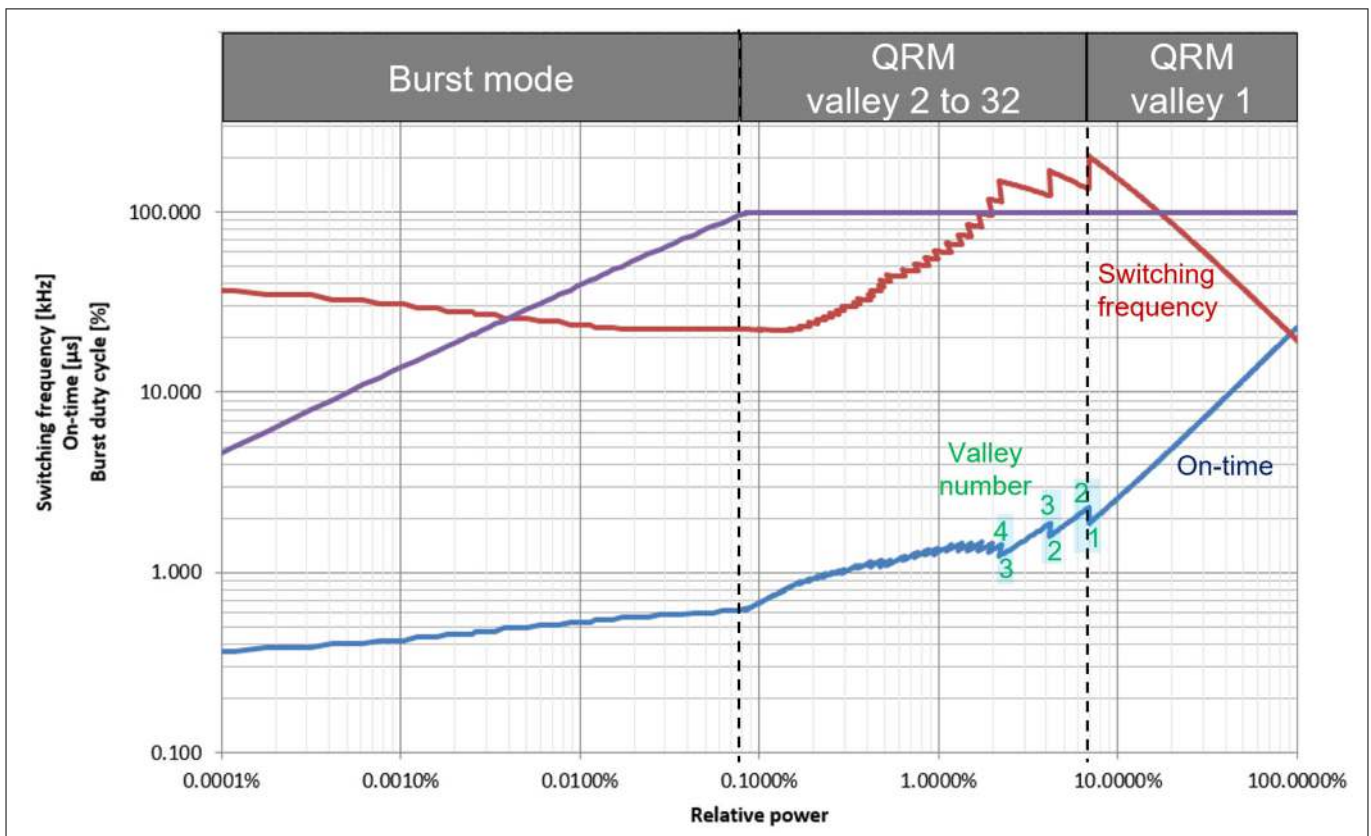

Figure 10 Exemplary switching characteristics versus relative power, with on-time compensation for valley changing (burst mode applies to ICL8810 and ICL8820 only)

Burst mode for ICL8810 and ICL8820

Burst mode transfers lesser power than QRM, to support light loads and no load/standby operation. To achieve a low standby power, the controller sleeps during burst pause, to reduce its current consumption. In addition, the controller operates in burst mode with a reduced gate driver voltage level of  $V_{GDred}$  (7 V typ.), to minimize the gate charge loss.

The controller wakes up at a regular repetition frequency  $f_{wake,reg}$ , to do the burst pulsing based on the measured VS pin load current signal, and goes to sleep during burst pause, as shown in Figure 11.

$f_{wake,reg}$  is approximately four times the last synced input line frequency. For example,  $f_{wake,reg}$  is around 240 Hz, if the last synced input line frequency is 60 Hz.

3 Functional description

Note: In case of non-line-syncing happened before entering the burst mode,  $f_{wake,reg} = 200 \text{ Hz typ.}$  is applied. For example, non-line-syncing can happen when the system is supplied with a DC input or when the VS pin load current ripple is very small at low load.

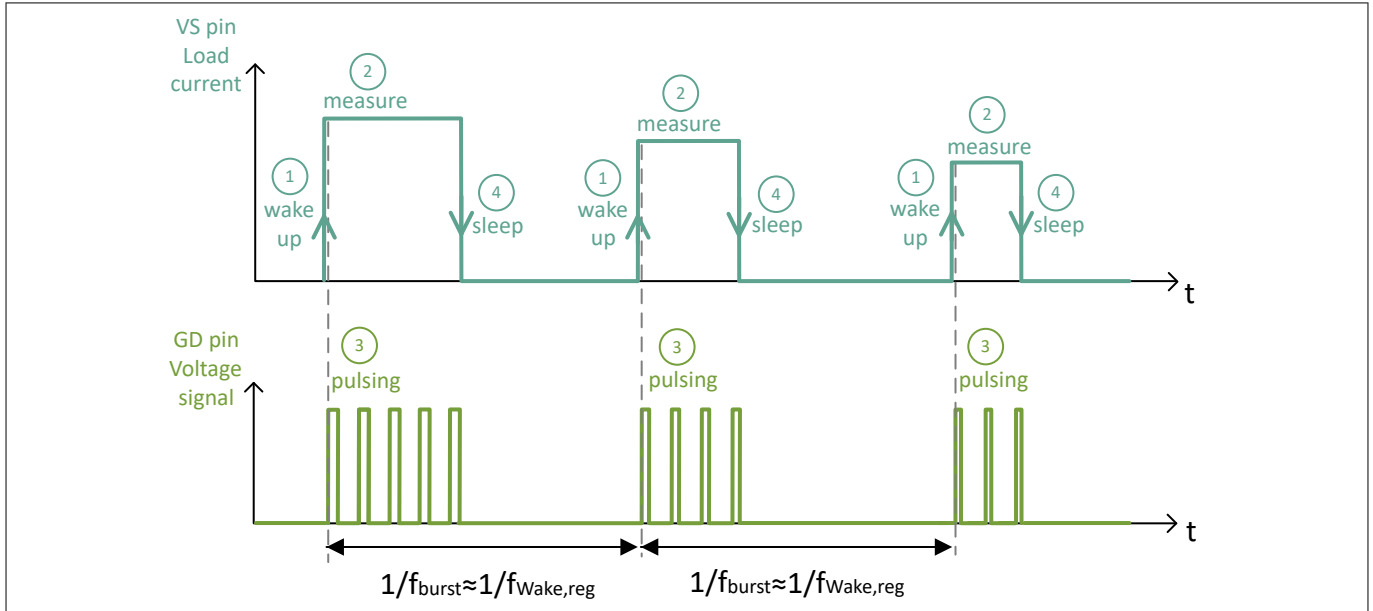

**Figure 11 Illustration of ICL8810 and ICL8820 burst mode with regular wake-up interval**

To maintain sufficient  $V_{VCC}$  in burst mode, the controller operates with the following two mechanisms:

- Instead of waking up based on the regular  $f_{wake,reg}$ , a higher priority  $V_{CC}$  wake-up threshold can trigger a burst start if  $V_{VCC}$  drops to  $V_{VCCwake}$  (7.6 V typ.). The controller continues the burst pulsing until  $V_{VCC} = V_{VCCburst}$  (8.1 V typ.).
- The  $TD$  pin internal pull-up resistor is disabled when  $V_{VCC}$  drops to  $V_{VCCwake}$ , to allow an external start-up circuit to charge  $V_{VCC}$  to  $V_{VCCburst}$ .

As a result, the burst cycle  $1/f_{burst}$  does not necessarily follow  $1/f_{wake,reg}$ , as shown in Figure 11. The burst cycle can be extended by an integer times of  $1/f_{wake,reg}$  in case of a burst pulse skipping, or can be reduced by a portion of  $1/f_{wake,reg}$  in case of a  $V_{CC}$  wake-up burst triggering, or from a combination of both effects.

**Attention:** *The  $V_{CC}$  wake-up burst control mechanism is intended to work with the  $V_{CC}$  voltage supply via the ZCD winding. In case of the  $V_{CC}$  voltage is supplied via a winding voltage, which follows a certain ratio of the primary bus voltage, it is a must to ensure that the  $V_{CC}$  voltage during burst mode is always higher than  $V_{VCCburst}$  maximum value (9.1 V maximum) by a sufficient margin, especially when the input voltage is low and close to brownout level, so that the  $V_{CC}$  wake-up burst mechanism can be avoided, to achieve a good output regulation.*

3 Functional description

3.8 Pulse generation

In RUN state, the ICL88xx maps the measured VS pin load current to the virtual pulse length, valley number and burst duty cycle, as shown in Figure 12.

These internal parameters are processed together with the power limitation and frequency jitter parameters, and fed to the pulse generation and THD correction function block, as shown in the Block diagram.

Note: The pulse generation for burst mode applies to ICL8810 and ICL8820 only. Frequency jitter applies to ICL8820 only.

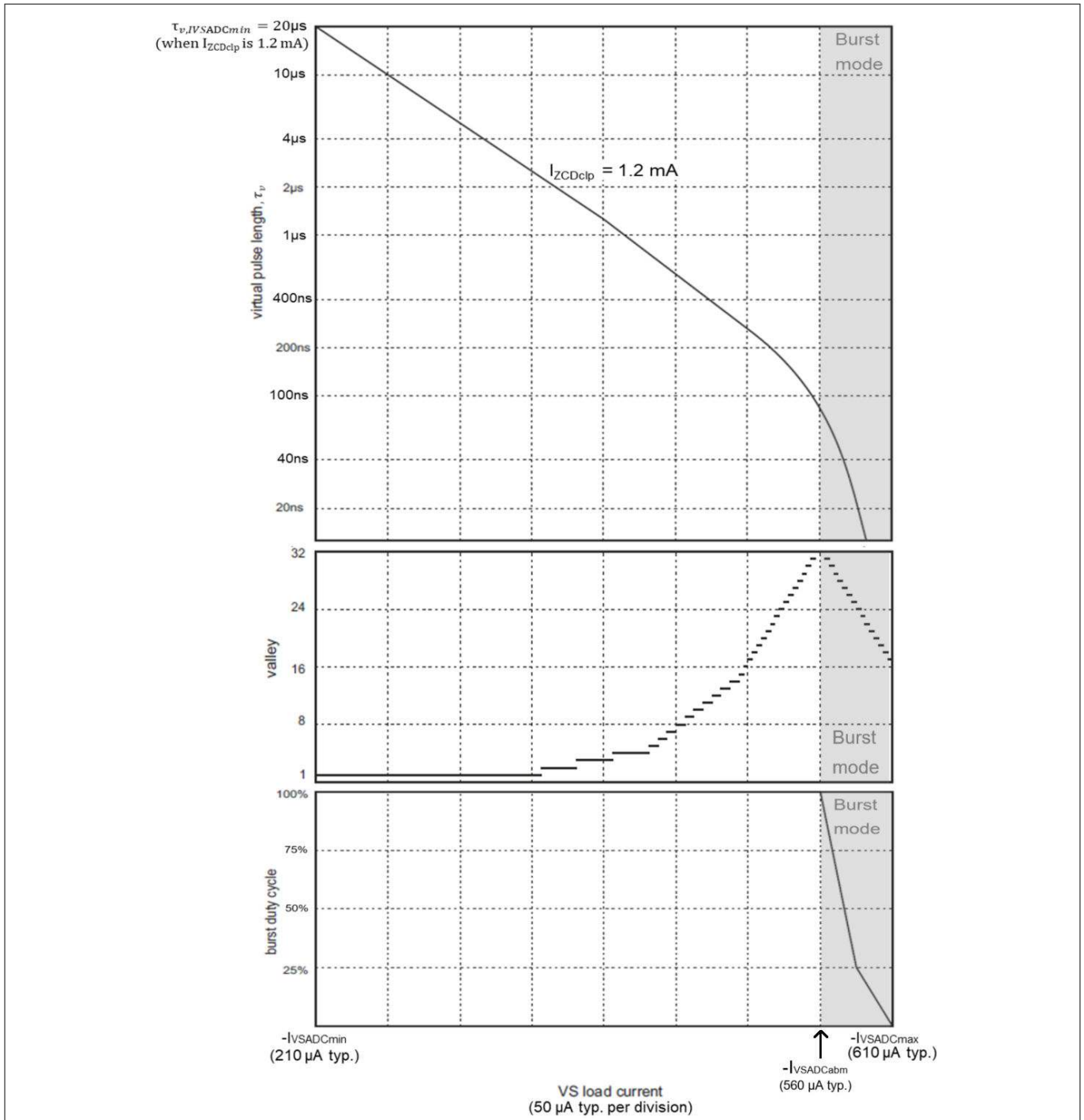

Figure 12 Virtual pulse length mapping (based on  $I_{ZCDclp} = 1.2 \text{ mA}$  as an example), valley number mapping and burst mode mapping (burst mode applies to ICL8810 and ICL8820 only)



3 Functional description

Virtual pulse length mapping and its use case

The virtual pulse length mapping is an illustrative on-time mapping which excludes:

- the system-dependent on-time compensation effect for valley number change (see Figure 10)
- the on-time extension effect for THD correction (see Figure 8)
- the power limiting effect on the maximum on-time (to be explained in this chapter)
- the virtual pulse length modulation effect from the DC input frequency jitter function - applies to ICL8820 only (to be explained in this chapter)
- the minimum gate pulse length limit by the pulse generation block

The virtual pulse length mapping shown in Figure 12 is not static.

It shifts vertically based on the ZCD pin peak to peak settled clamping current  $I_{ZCDclp}$ , which is dependent on the  $R_{ZCD}$ , transformer winding turns ratio, operating input and output voltages.

As shown in Figure 13, a different  $I_{ZCDclp}$  level leads to a change on the virtual pulse length at every valley-changing position, including the burst mode entry position. It means when the input voltage is lower or when  $R_{ZCD}$  value is increased for example, a decrease of  $I_{ZCDclp}$  leads to the relative on-time decrease at every valley-changing position, including the burst mode entry position. And vice-versa.

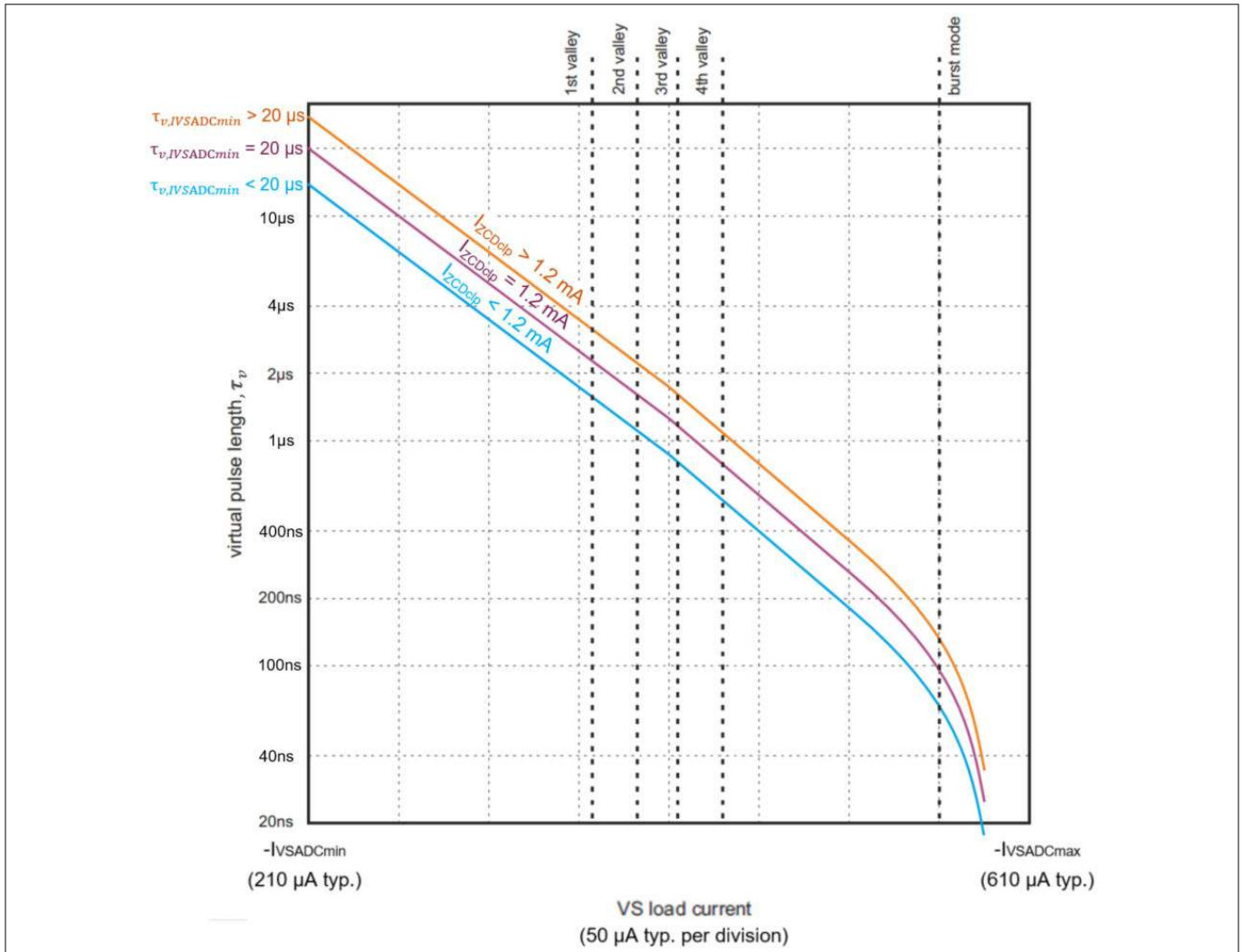

Figure 13 Effect of  $I_{ZCDclp}$  change on the virtual pulse length mapping

As an example, the virtual pulse length mapping based on  $I_{ZCDclp} = 1.2 \text{ mA}$  in Figure 13 is derived based on the following steps:



### 3 Functional description

1. Based on  $I_{ZCDclp} = 1.2 \text{ mA}$ , obtain  $\tau_{v,IVSADCmin} = 20 \mu\text{s}$  from [Figure 14](#).
2. Mark  $\tau_{v,IVSADCmin} = 20 \mu\text{s}$  on the y-axis, and take it as the starting point for the virtual pulse length mapping curve plot, which is relatively well exponential in the range from  $20 \mu\text{s}$  to  $1 \mu\text{s}$ , with a halving of the pulse length per  $50 \mu\text{A}$  VS pin load current increase.

For example, another practical use case of the virtual pulse length mapping is to estimate the minimum on-time of the QRM 1<sup>st</sup> valley switching (approximately 10% of  $\tau_{v,IVSADCmin}$ ), to estimate the system maximum switching frequency.

*Note: When the valley number is higher than 1 in QRM, or when in burst mode, the virtual pulse length mapping value should not be taken directly as the estimated on-time, since it excludes the on-time compensation effect for valley number change.*

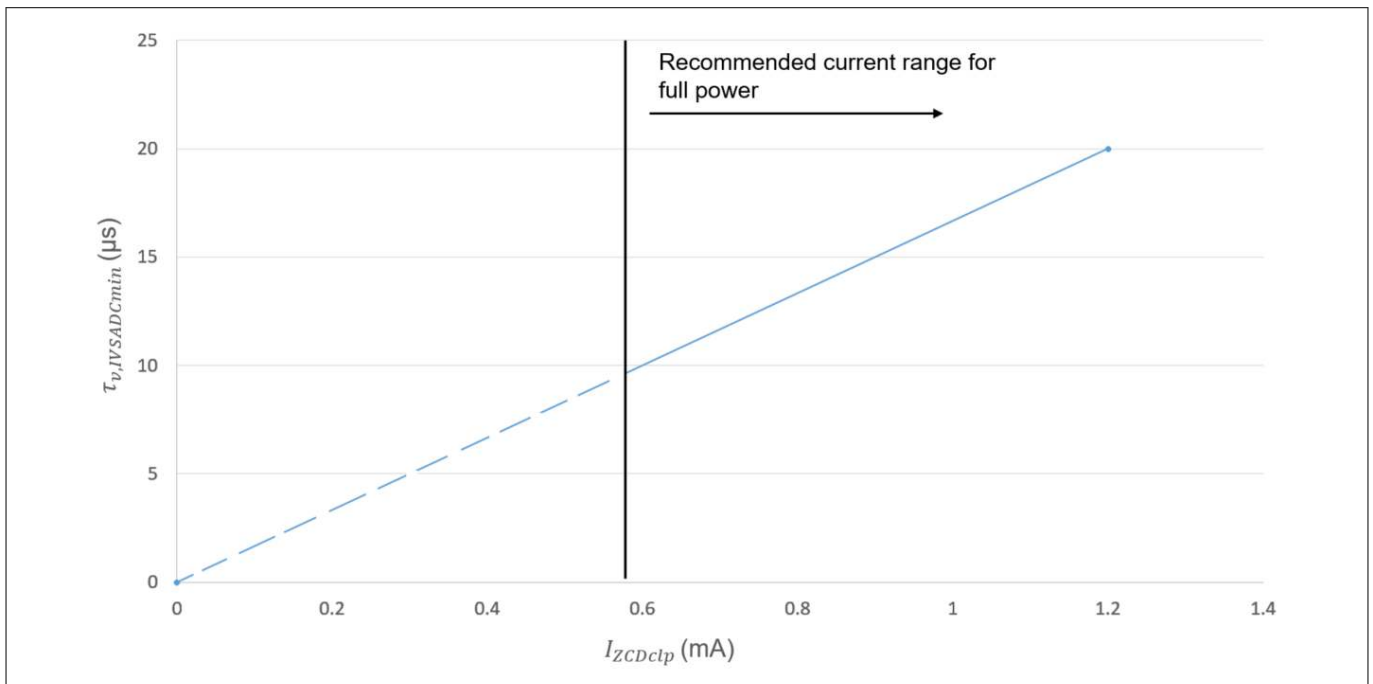

**Figure 14** Virtual pulse length at  $I_{VSADCmin}$ ,  $\tau_{v,IVSADCmin}$  versus ZCD peak to peak settled clamping current,  $I_{ZCDclp}$

#### Power-limitation and maximum on-time

The ICL88xx power limitation features limit the maximum on-time  $t_{ON,max}$  based on:

$$t_{ON,max} \approx \tau_{v,IVSADCmin} \cdot \min \left[ 1, \frac{1}{2^{3.058 \cdot \ln\left(\frac{V_{VIN,avg}}{0.4}\right) - 1.25}} \right]$$

#### Equation 5

For  $t_{ON,max}$  estimation, it is important to note that  $\tau_{v,IVSADCmin}$  changes with different  $V_{VIN,avg}$  level, when the input voltage detection circuit in [Figure 6](#) is applied. This is because  $\tau_{v,IVSADCmin}$  is scaled exponential depending on  $I_{ZCDclp}$  in [Figure 14](#), while  $I_{ZCDclp}$  is dependent on the input voltage, as explained in [ZCD pin signal sensing](#).

$t_{ON,max}$  is applied when the VS pin load current is  $I_{VSton,sat}$  or lower, where  $I_{VSton,sat}$  can be estimated based on:

$$-I_{VSton,sat} \approx -I_{VSADCmin} + \max \left[ 0, 152.9 \cdot \ln\left(\frac{V_{VIN,avg}}{0.4}\right) - 62.5 \right] \cdot 10^{-6}$$

#### Equation 6

3 Functional description

Figure 15 shows the virtual pulse length with the power limiting maximum on-time effect, when  $V_{VIN,avg}$  is 0.65 V, 1.0 V, 1.5 V and 1.9 V, respectively.

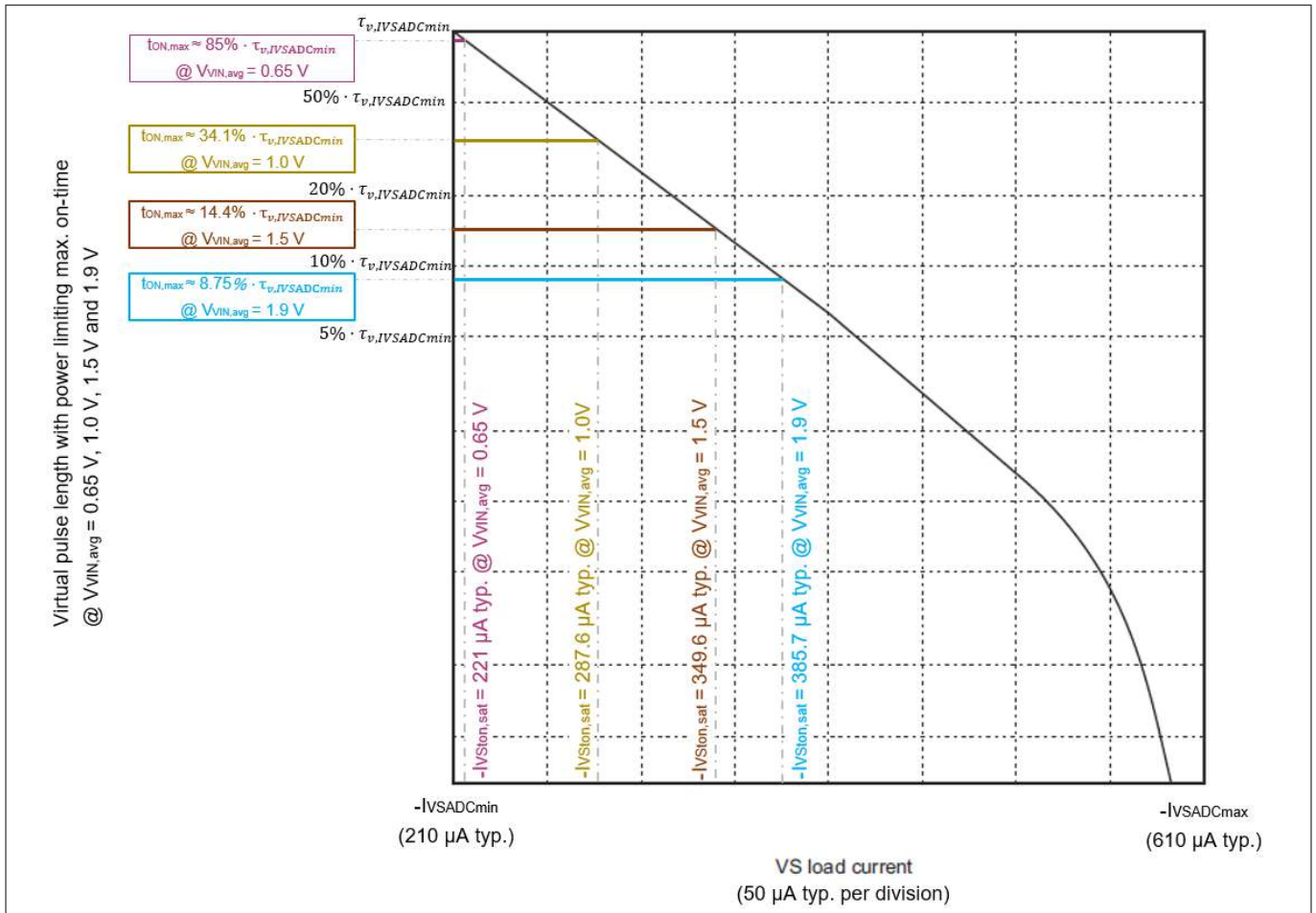

**Figure 15 Virtual pulse length mapping with power limiting maximum on-time effect**

When  $V_{VIN,avg}$  is in the range from the brownout level (0.44 V typ.) to approximately 0.6 V, the power limitation is disabled, where  $t_{ON,max} = \tau_{v,IVSADCmin}$ .

When  $V_{VIN,avg}$  is at the brownin level ( $V_{BI} = 0.65$  V typ.), the power limitation is enabled with  $t_{ON,max} = 85\%$  of  $\tau_{v,IVSADCmin}$ , as shown in Figure 15. For example, if the desired  $t_{ON,max}$  at brownin level is 17  $\mu$ s typ., it is necessary to have  $\tau_{v,IVSADCmin} = 17 \mu$ s / 85% = 20  $\mu$ s. And, according to Figure 14,  $\tau_{v,IVSADCmin} = 20 \mu$ s is obtained when  $I_{ZCDclp} = 1.2$  mA is applied. As a result, to achieve  $t_{ON,max} = 17 \mu$ s typ. at brownin level,  $R_{ZCD}$  should be dimensioned to produce  $I_{ZCDclp} = 1.2$  mA typ. at brownin level.

**Valley number and burst duty cycle**

The valley number and burst duty cycle mappings based on VS pin load current are shown in Figure 12. The burst duty cycle refers to the ratio of the burst pulsing duration to burst cycle time.  $-IVSADC_{abm}$  (560  $\mu$ A typ.) marks the boundary between QRM and burst mode.

Note: The pulse generation for burst mode applies to ICL8810 and ICL8820 only.

In QRM, the mapped valley number is not necessarily taken directly or immediately as the ZCD pin valley-count number, for the pulse generation. The update of the ZCD pin valley-count number is done based on the following valley selection hysteresis mechanism:

1. To minimize the multiple valley changes within one AC half cycle, ICL88xx updates the ZCD valley-count number once every AC half cycle, based on the lowest mapped valley number from the last AC half cycle,

3 Functional description

as shown in Figure 16. During each AC half cycle, the controller adjusts the on-time to stay in the selected valley number. In this way, the number of valley jumps is limited to a minimum.

- When a load jump happens, if the valley number has to be decreased, it happens immediately. For the case of valley number increase, if the load jump results to a valley number increase by 10 or more, it happens immediately. Otherwise, the change happens only at the start of the next AC half cycle, as shown in Figure 16.

*Note: If the selected ZCD valley-count number cannot happen before the maximum off-time  $t_{off}$  (47  $\mu s$  typ.) is reached, the pulse generation will be based on  $t_{off}$ , instead of the selected ZCD valley counting number.*

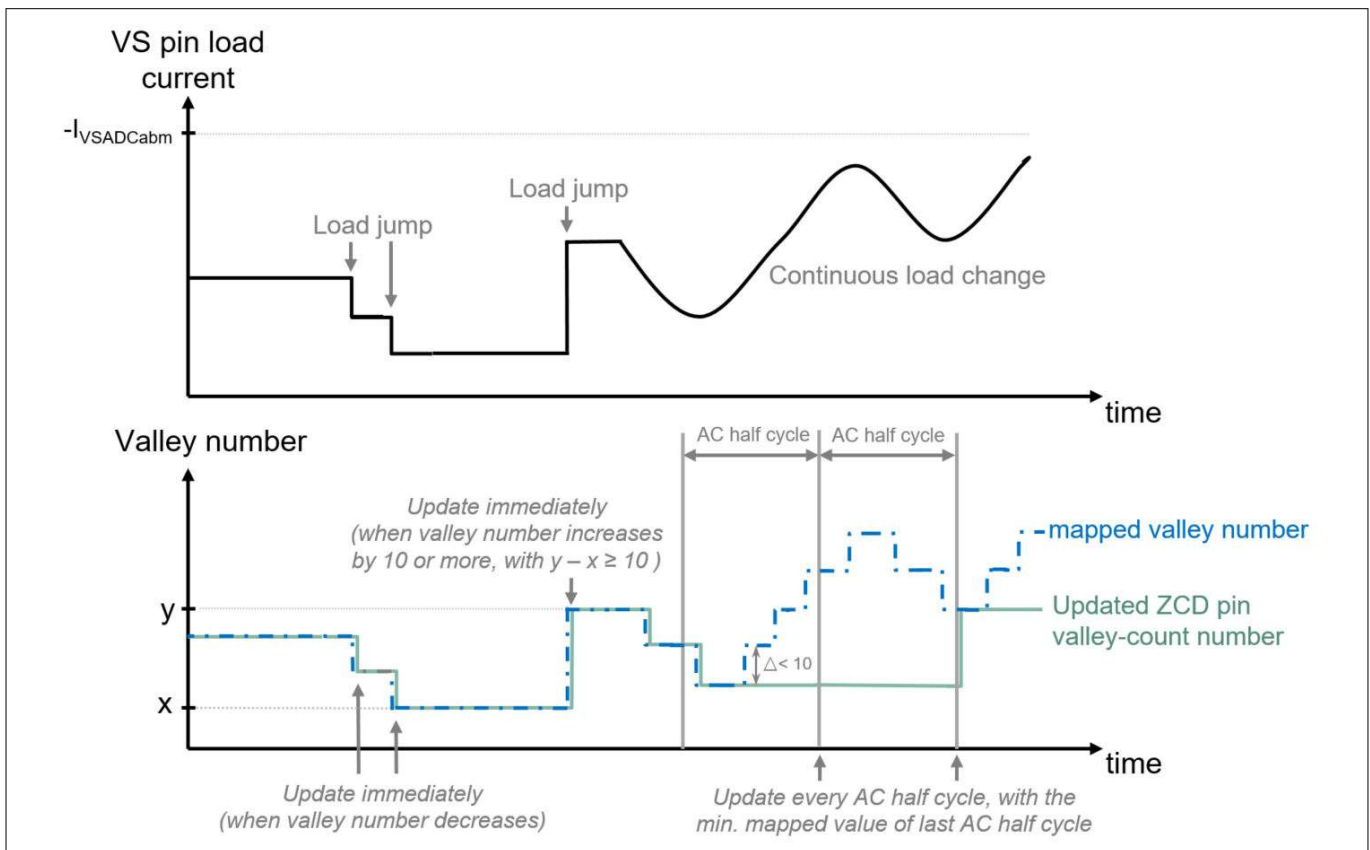

**Figure 16** Illustrative example of the QRM valley selection hysteresis mechanism

*Note: If the AC half cycle period cannot be synced, for example when the input voltage is DC, or when the VS pin load current ripple is very small, the regular valley update cycle will be based on either approximately 10 ms, or the last synced AC half cycle period.*

In burst mode, the controller measures the VS load current at a regular wake-up interval, and applies the mapped valley number immediately as the ZCD pin valley-count number for the burst switching pulse generation. Also, the mapped burst duty cycle is taken immediately to determine the burst pulsing duration, as shown in Figure 11. If the measured VS load current is  $-I_{VSADCmin}$  (610  $\mu s$  typ.) or more, the burst pulsing is skipped.

Instead of waking up based on the regular interval, a higher priority VCC wake-up threshold can trigger a burst start if  $V_{VCC}$  drops to  $V_{VCCwake}$  (7.6 V typ.). In case of VCC wake-up burst being triggered, the burst pulsing duration depends on the time needed to charge the  $V_{VCC}$  from  $V_{VCCwake}$  to  $V_{VCCburst}$  (8.1 V typ.).

**Attention:** *The VCC wake-up burst control mechanism is intended to work with the VCC voltage supply via the ZCD winding. In case of the VCC voltage is supplied via a winding voltage, which follows a certain ratio of the primary bus voltage, it is a must to ensure that the VCC voltage during burst mode is always higher than  $V_{VCCburst}$  maximum value (9.1 V maximum) by a sufficient margin,*

### 3 Functional description

*especially when the input voltage is low and close to brownout level, so that the VCC wake-up burst mechanism can be avoided, to achieve a good output regulation.*

#### Burst mode regular wake-up interval and burst cycle time

Refer to the burst mode section in the [Operating modes](#) chapter.

#### DC input frequency jitter

*Note:* The frequency jitter function applies to ICL8820 only.

When a DC input voltage is detected via the *VIN* pin, a triangular pattern is injected into the pulse generation, with a repetition frequency of  $f_{\text{triangular}}$ . The triangular pulse modulation can be compared to the change in pulse generator output, with the artificial current change pattern shown in [Figure 17](#) applied to the measured *VS* pin load current.

With DC input voltage, the on-time can therefore be modulated in QRM. Since the transformer demagnetization time is proportionate to the modulated on-time, the QRM switching frequency jitters. The resulting jitter frequency range depends not only on the on-time modulation itself and the *ZCD* valley-count number, but also the duty cycle and oscillation period, which are both system-dependent.

$f_{\text{triangular}}$  is approximately 222 Hz and 266.4 Hz for the last synced input line frequency of 50 Hz and 60 Hz respectively.

*Note:* In case of non-line-syncing,  $f_{\text{triangular}} = 222 \text{ Hz typ.}$  is applied. For example, non-line-syncing can happen when the system is started up with a DC input.

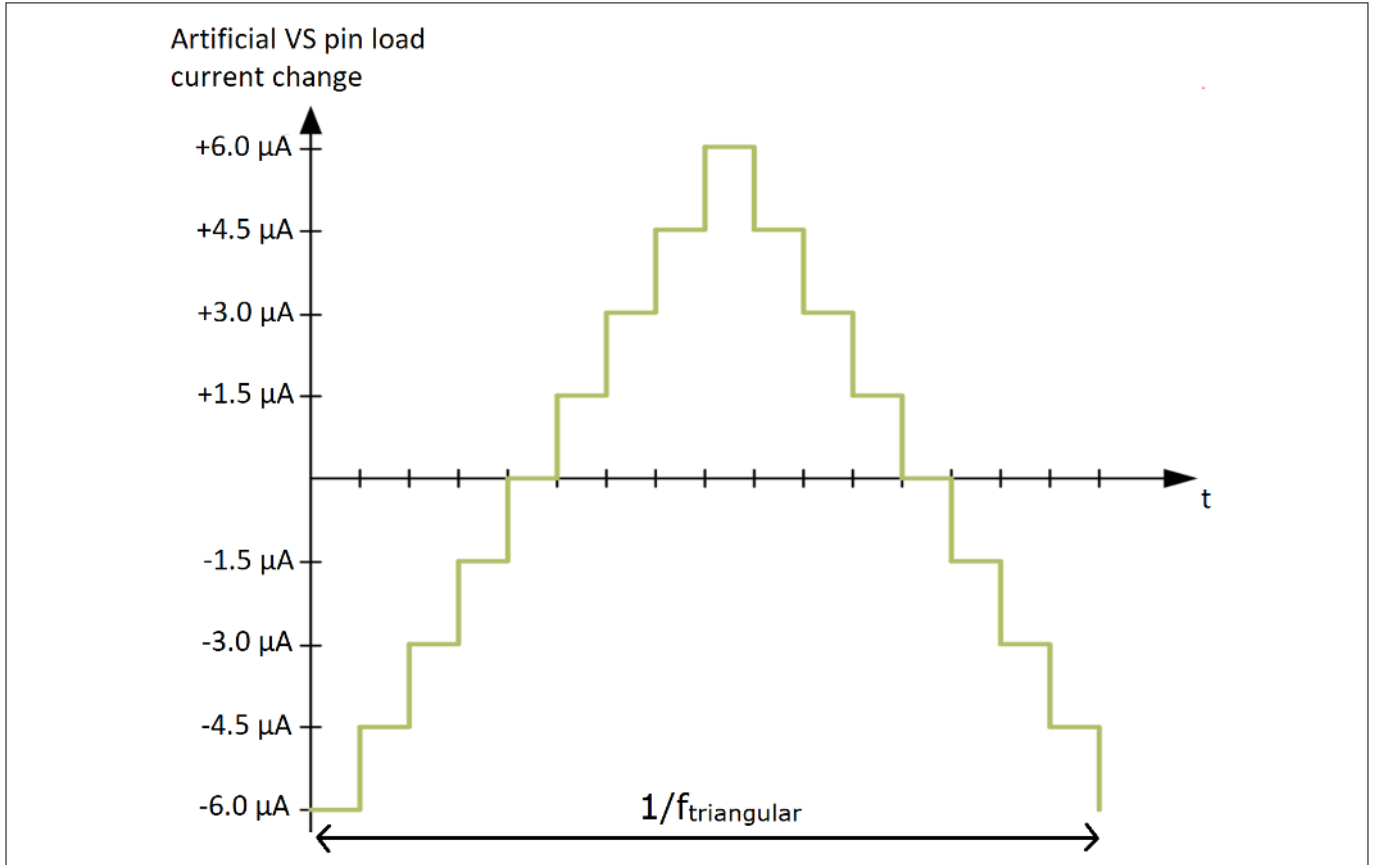

**Figure 17** Artificial load current change pattern applied on *VS* pin measured current for the pulse generator output change, to resemble the pulse modulation mechanism for the DC input frequency jitter function

3 Functional description

3.9 Primary side overcurrent protection

The primary side overcurrent protection level 1 (OCP1) is performed by means of the cycle-by-cycle peak current limitation. An internal leading edge blanking  $t_{LEB}$  (160 ns typ.) prevents false triggering of this protection due to a leading edge spike. If the measured CS pin voltage exceeds  $V_{OCP1}$  (0.61 V typ.) for more than  $t_{LEB}$  (160 ns typ.), the protection is triggered and the GD pin output is pulled low for that switching cycle. The primary side overcurrent protection level 2 (OCP2) is meant for covering fault conditions like a short in the transformer primary winding or transformer core saturation. In this case, the OCP1 does not limit properly the peak current due to the very steep slope of the peak current. If the measured CS pin voltage with an initial level of at least  $V_{OCP1}$  reaches  $V_{OCP2}$  (1.21 V typ.) or more within the time window of  $t_{OCP2}$  (150 ns typ.), the OCP2 protection is triggered.

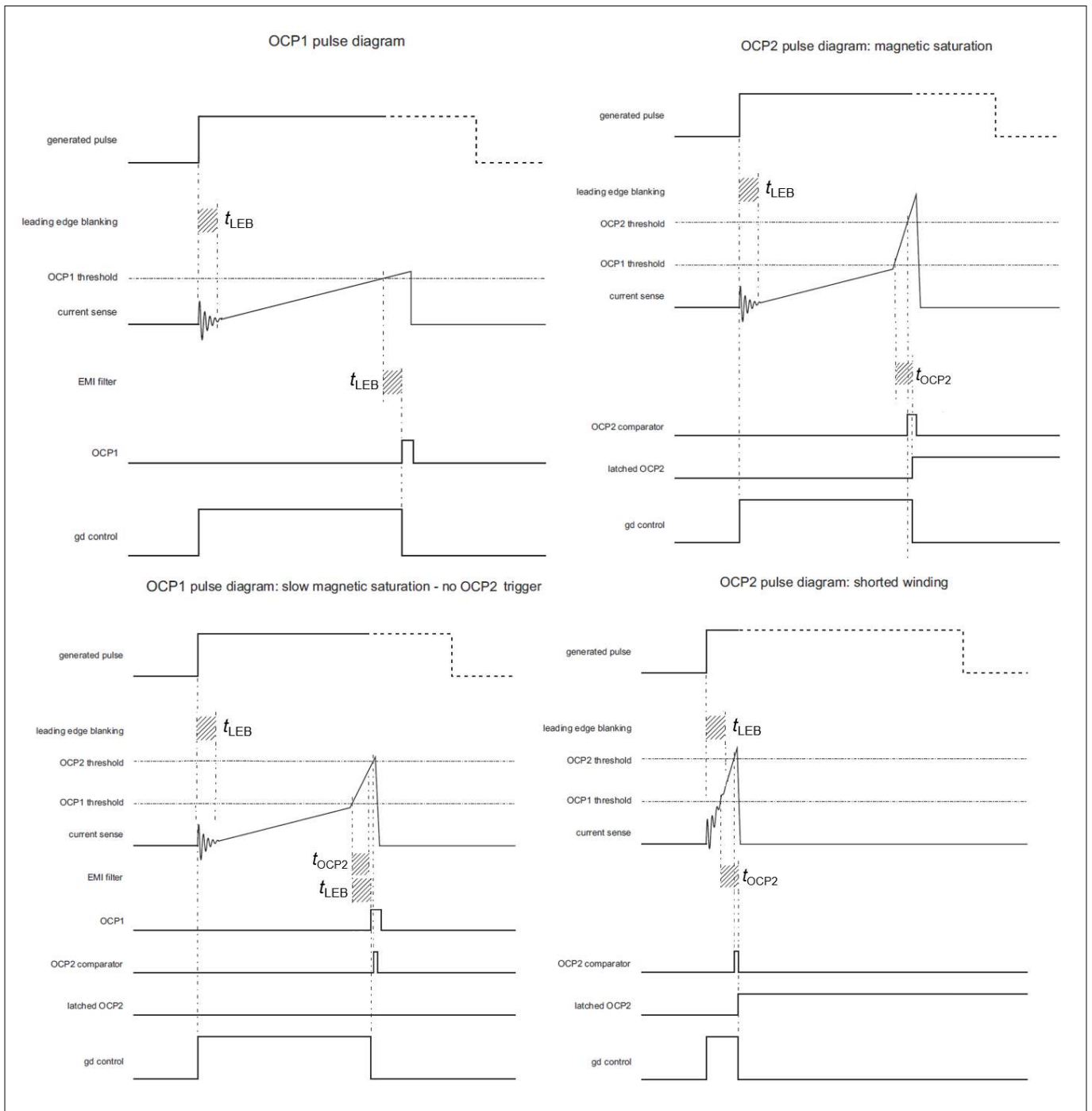

Figure 18 Timing overview of the OCP1 and OCP2

### 3 Functional description

#### 3.10 VCC voltage protections

An UVLO is implemented to activate and deactivate the controller depending on the supply voltage on the VCC pin. The UVLO contains a hysteresis with the voltage thresholds  $V_{VCCon}$  (12.5 V typ.) for activating the controller and  $V_{VCCmin}$  (6.6 V typ.) for deactivating the controller.

When the controller is not active, the current consumption is  $I_{VCCstart}$  (30  $\mu$ A typ.).

If the voltage on VCC pin reaches  $V_{VCCclamp}$  (24.2 V typ.) during start-up, restart and in the burst pause, the controller is able to sink up to  $I_{VCCclamp}$  (2.5 mA typ.). The VCC overvoltage protection is implemented based on a threshold of  $V_{VCCmax}$  (25 V typ.).

##### VCC wake-up burst (for ICL8810 and ICL8820 only)

To maintain sufficient  $V_{VCC}$  in burst mode, the controller operates with the following two mechanisms:

- The VCC wake-up threshold can trigger a burst start if  $V_{VCC}$  drops to  $V_{VCCwake}$  (7.6 V typ.). The controller continues the burst pulsing until  $V_{VCC} = V_{VCCburst}$  (8.1 V typ.).
- The TD pin internal pull-up resistor is disabled when  $V_{VCC}$  drops to  $V_{VCCwake}$ , to allow an external start-up circuit to charge  $V_{VCC}$  to  $V_{VCCburst}$ .

**Attention:** *The VCC wake-up burst control mechanism is intended to work with the VCC voltage supply via the ZCD winding. In case of the VCC voltage is supplied via a winding voltage, which follows a certain ratio of the primary bus voltage, it is a must to ensure that the VCC voltage during burst mode is always higher than  $V_{VCCburst}$  maximum value (9.1 V maximum) by a sufficient margin, especially when the input voltage is low and close to brownout level, so that the VCC wake-up burst mechanism can be avoided, to achieve a good output regulation.*

#### 3.11 Flyback output overvoltage protection

During the transformer demagnetization time, the ZCD pin positive peak settled current  $I_{ZCDpclip}$  is internally converted to a current flowing out of the CS pin with the conversion ratio  $n_{ZCDOVP}$ . The CS pin voltage level at this time is therefore approximately the multiplication of this out-flowing current and the CS pin resistance to ground. If this voltage level exceeds the  $V_{OCP1}$  threshold (0.61 V typ.) for more than a blanking time, the flyback OVP is triggered.

Since the CS pin series resistor value is very much greater than the primary MOSFET current shunt resistor value, the flyback output OVP level can be adjusted based on the CS pin series resistance.

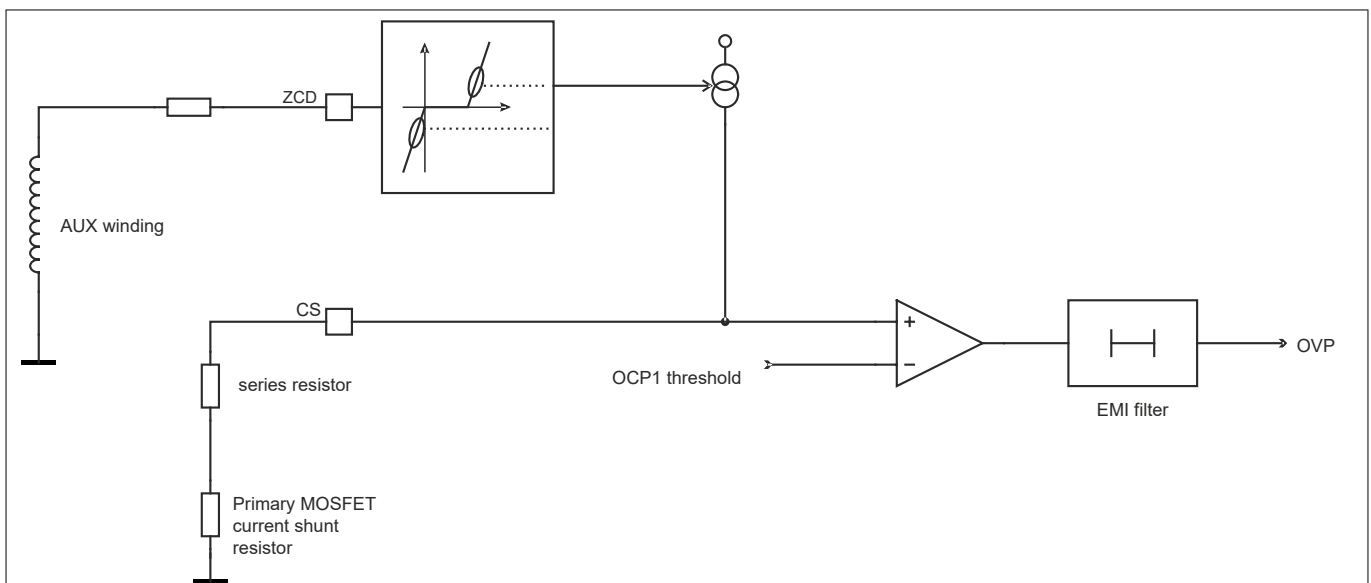

Figure 19 Flyback secondary output OVP

### 3 Functional description

Due to this protection, the voltage on CS pin is not zero during the transformer demagnetization, but mirrors the reflected output voltage.

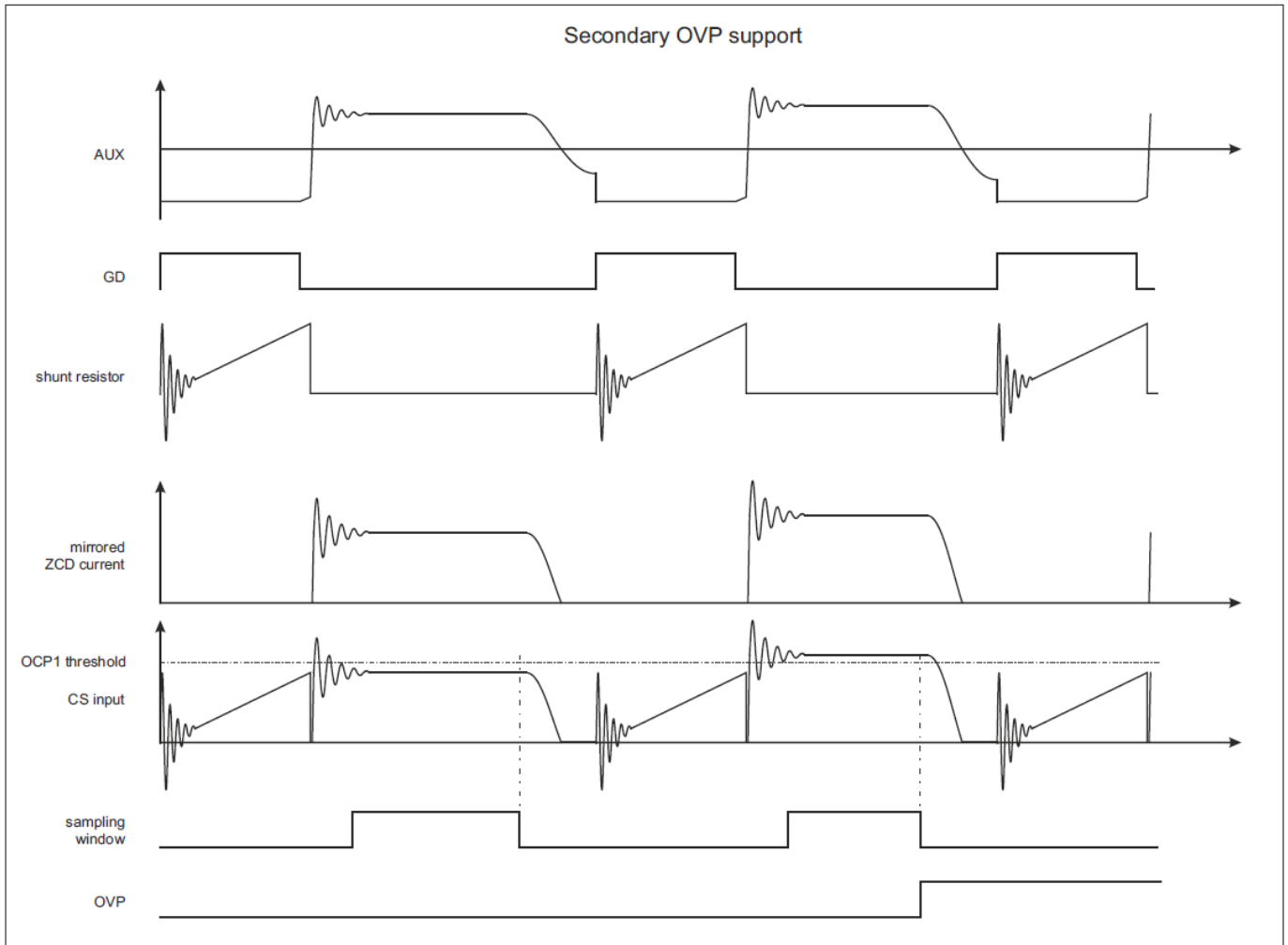

Figure 20 Flyback CS waveform

### 3.12 Overtemperature protection

ICL88xx offers an overtemperature protection using an internal temperature sensor. The overtemperature protection is triggered when internal junction temperature  $T_j$  reaches  $T$  (130°C typ.).

### 3.13 Open loop protection

An open feedback loop results in maximum power transfer after the soft start. The [flyback output overvoltage protection](#) can be triggered once the overvoltage threshold is exceeded for longer than the related blanking time. This causes an auto-restart.

In the case of an open VS pin, due to the VS pin sourcing a current of  $-I_{VS\text{Bias}}$  (1  $\mu\text{A}$  typ.) out of the controller during normal operation, the VS pin voltage rises. The VS pin voltage is compared to the overvoltage comparator threshold  $V_{VS\text{OVFFB}}$  (2.7 V typ.). If the voltage exceeds the threshold for longer than the related blanking time, the VS pin overvoltage protection blocks any switching. A reset may occur if the VCC voltage drops below  $V_{VCC\text{min}}$ .



3 Functional description

3.14 State flow chart and fault reaction

Flow chart

The Figure 21 shows the different states of the IC and the conditions to change the state.

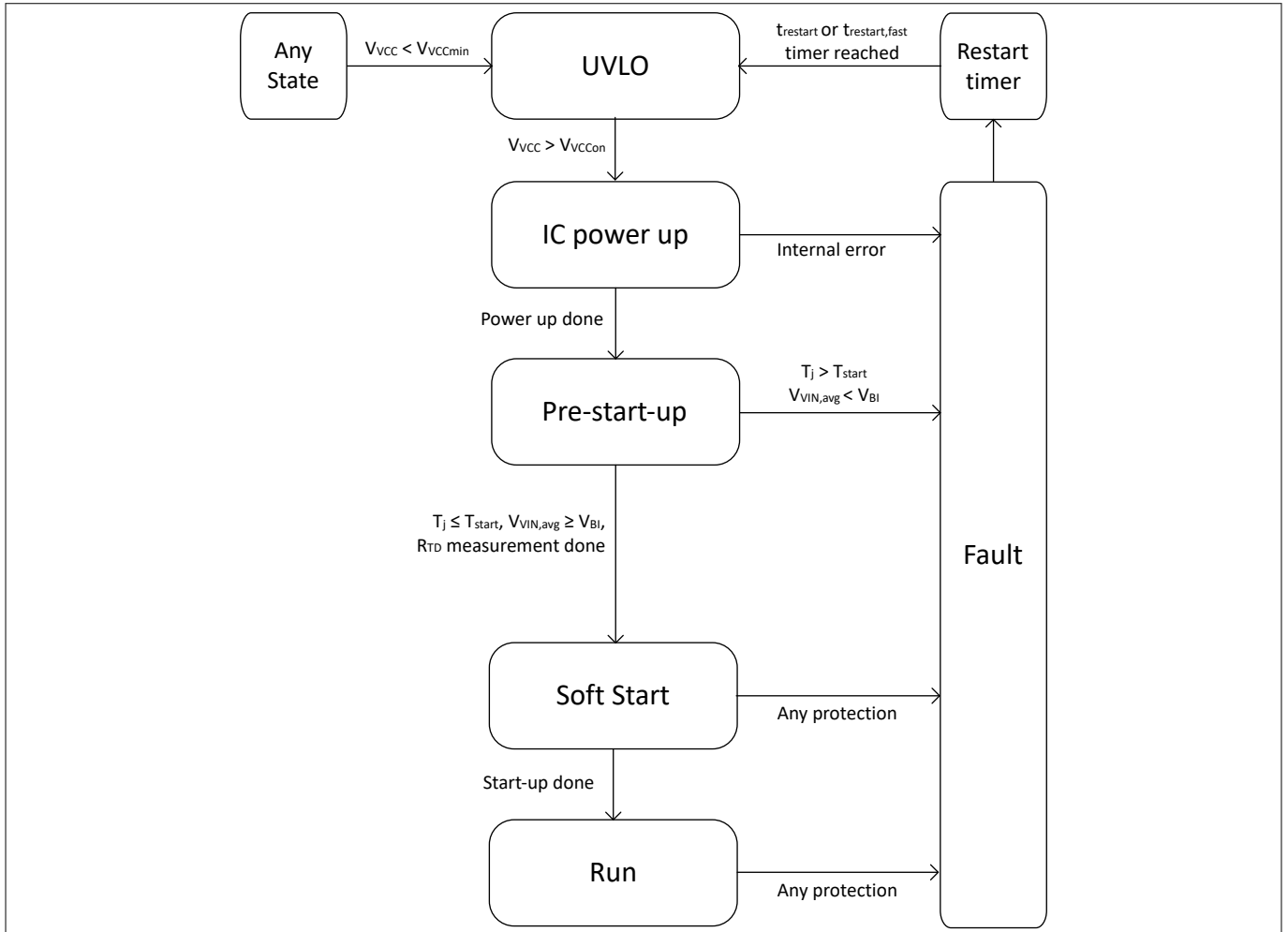

Figure 21 State flow chart

Fault reaction

The controller handles protections as listed in Table 2.

Note: Some blanking times vary slightly with the line frequency.



**3 Functional description**

**Table 2**            **Fault matrix**

Fault	Detection	Typical blanking time	State			Reaction
			Pre-start-up	Soft start	Run	
Insufficient supply	$V_{VCC} < V_{VCCon}$	1 $\mu$ s	X	-	-	Wait in reset
Insufficient supply	$V_{VCC} < V_{VCCmin}$	1 $\mu$ s	X	X	X	Reset
VCC overvoltage	$V_{VCC} > V_{VCCOVP}$	1 $\mu$ s	-	X	X	Auto-restart after $t_{restart}$
VIN short protection	$V_{VIN} < V_{VINshort}$	1 $\mu$ s	-	X	X	Auto-restart after $t_{restart}$
Brownin protection	$V_{VIN,avg} < V_{BI}$	2 ms	X	-	-	Fast auto-restart after $t_{restart,fast}$
Brownout protection	$V_{VIN,avg} < (V_{BI} - \Delta V_{BI-BO})$	2 ms	-	X	X	Auto-restart after $t_{restart}$
VIN overvoltage protection	$V_{VIN,avg} > V_{VINOV}$	2 ms	-	X	X	Auto-restart after $t_{restart}$
Overcurrent protection (OCP1)	$V_{CS} > V_{OCP1}$	$t_{LEB}$	-	X	X	Turn off gate driver for the on-going switching cycle
Overcurrent protection (OCP2)	$V_{CS} > V_{OCP2}$	$t_{OCP2}$	-	X	X	Auto-restart after $t_{restart}$
Flyback output overvoltage protection	$I_{ZCDpclip} * n_{ZCDOVP} > V_{OCP1}$	100 $\mu$ s	-	X	X	Auto-restart after $t_{restart}$
Overtemperature	$T_j > T$ or $T_j > T_{start}$	18 $\mu$ s	X	X	X	Auto-restart after $t_{restart}$
VS overvoltage	$V_{VS} > V_{VSOVFFB}$	20 $\mu$ s	-	X	X	Turn off gate driver and restart if $V_{VS} < V_{VSOVONFB}$

**3.15**            **Adjustable functions**

Some features of the controller can be adjusted using external circuitry:

- The maximum power/on-time/operating point can be configured using the ZCD pin series resistance to the ZCD/auxiliary winding
- The flyback output overvoltage protection can be configured using the CS pin series resistance to the primary MOSFET current shunt resistor.
- Brownin and brownout protection and the related input overvoltage protection
- Primary side overcurrent protection

Refer to the Design Guide for details.

4 Electrical characteristics and parameters

4 Electrical characteristics and parameters

All signals are measured with respect to the ground pin, *GND*. The voltage levels are valid provided that other ratings are not violated.

4.1 Absolute maximum ratings

*Note:* Absolute maximum ratings are defined as ratings, which if exceeded may lead to destruction of the integrated circuit. Exposure to absolute maximum rating conditions for extended periods may affect device reliability. Maximum ratings are absolute ratings; exceeding only one of these values may cause irreversible damage to the integrated circuit. These values are not tested during production test.

Table 3 Absolute maximum ratings

Parameter	Symbol	Values			Unit	Note or test condition
		Min.	Typ.	Max.		
VCC voltage	$V_{VCC}$	-0.5	–	26	V	
Junction temperature	$T_j$	-40	–	150	°C	
Storage temperature	$T_S$	-55	–	150	°C	
Soldering temperature	$T_S$	–	–	260	°C	Wave soldering according to JESD22-A111 Rev A.
Thermal resistance junction to ambient	$R_{ThJA}$	–	–	185	K/W	
Power dissipation at 50°C	$P_D$	–	–	0.5	W	
ESD capability HBM	$V_{ESD}$	–	–	2	kV	ESD-HBM according to ANSI/ESDA/JEDEC JS-001.
ESD capability CDM	$V_{ESD}$	–	–	500	V	ESD-CDM according to ANSI/ESDA/JEDEC JS-002.
GD voltage	$V_{GD}$	-0.5	–	$V_{VCC} + 0.3$	V	
CS voltage	$V_{CS}$	-0.5	–	3.6	V	
CS current	$I_{CS}$	-2	–	2	mA	
ZCD voltage	$V_{ZCD}$	-1.2	–	3.6	V	
ZCD current	$I_{ZCD}$	-4	–	4	mA	
VS voltage	$V_{VS}$	-0.3	–	3.6	V	
VIN voltage	$V_{VIN}$	-0.3	–	3.6	V	
TD voltage	$V_{TD}$	-0.3	–	3.6	V	

## 4 Electrical characteristics and parameters

### 4.2 Operating conditions

The recommended operating conditions are shown for which the DC electrical characteristics are valid.

**Table 4** Operating characteristics

Parameter	Symbol	Values			Unit	Note or test condition
		Min.	Typ.	Max.		
Junction temperature	$T_J$	-40	-	$T$	°C	
Supply voltage	$V_{VCC}$	$V_{VCCburst}$	-	23	V	
External capacitance at the $TD$ pin	$C_{TD}$	-	-	1	nF	
ZCD pin peak to peak settled clamping current	$I_{ZCDclp}$	-	-	1.2	mA	For $V_{VIN} = 0.6$ V DC after internal averaging
Line frequency for AC input	$f_{line}$	45	-	66	Hz	

### 4.3 DC electrical characteristics

The electrical characteristics provide the spread of values applicable within the specified supply voltage and junction temperature range. Devices are tested in production at  $T_A = 25^\circ\text{C}$ . Values have been verified either with simulation models or by device characterization up to  $125^\circ\text{C}$ . Typical values represent the median values related to  $T_A = 25^\circ\text{C}$ .

All voltages refer to  $GND$ , and the assumed supply voltage is  $V_{VCC} = 15$  V, if not otherwise specified.

#### 4.3.1 Power supply

**Table 5** Power supply characteristics

Parameter	Symbol	Values			Unit	Note or test condition
		Min.	Typ.	Max.		
VCC turn-on threshold	$V_{VCCon}$	12.0	12.5	13.1	V	
Start-up current	$I_{VCCstart}$	-	30	-	$\mu\text{A}$	
Supply current	$I_{CC}$	-	2.0	-	mA	IC self-supply excluding gate currents.
Supply current during burst pause	$I_{CCburst}$	-	220	-	$\mu\text{A}$	
Supply current in protection mode	$I_{CCrestart}$	-	40	-	$\mu\text{A}$	
VCC undervoltage threshold	$V_{VCCmin}$	6.0	6.6	7.6	V	
VCC wake-up threshold	$V_{VCCwake}$	6.6	7.6	8.8	V	
VCC burst threshold	$V_{VCCburst}$	7.1	8.1	9.1	V	
Difference between $V_{VCCwake}$ and $V_{VCCburst}$	$V_{\Delta}$	500	-	-	mV	
VCC overvoltage threshold	$V_{VCCmax}$	23.8	25	26.4	V	
VCC clamp voltage	$V_{VCCclamp}$	-	24.2	-	V	
VCC clamp current	$I_{VCCclamp}$	-	2.5	-	mA	

4 Electrical characteristics and parameters

4.3.2 Zero crossing detection

Table 6 Electrical characteristics

Parameter	Symbol	Values			Unit	Note or test condition
		Min.	Typ.	Max.		
Zero crossing threshold (falling edge)	$V_{ZCDDown}$	10	45	–	mV	
Zero crossing threshold (rising edge)	$V_{ZCDUp}$	–	55	90	mV	
Clamping of positive voltages	$V_{ZCDpclip}$	400	550	700	mV	$I_{ZCDSink} = 1 \text{ mA}$
Clamping of negative voltages	$V_{ZCDnclip}$	-600	-500	-400	mV	$I_{ZCDSource} = -1 \text{ mA}$
ZCD ringing suppression time	$t_{Ringsup}$	350	700	1100	ns	
ZCD to CS current ratio for flyback secondary side OVP	$n_{ZCDOVP}$	0.455	0.484	0.513		$I_{CSsource} / I_{ZCDpclip}$ at 1.2 mA
ZCD to CS current ratio for flyback secondary side OVP	$n_{ZCDOVP}$	0.450	0.484	0.518		$I_{CSsource} / I_{ZCDpclip}$ at 0.8 mA

4.3.3 Voltage sense

Note:  $R_{TD}$  limits from Table 9 apply for Table 7.

Table 7 Electrical characteristics

Parameter	Symbol	Values			Unit	Note or test condition
		Min.	Typ.	Max.		
VS bias current	$-I_{VSBias}$	0.5	1.0	1.5	$\mu\text{A}$	$V_{VS} = V_{ref}$ .
Voltage source for optocoupler/ feedback supply	$V_{VS}$	1.56	1.6	1.63	V	Internal series resistance of 500 $\Omega$ .
VS current threshold for start up	$-I_{VSSink}$	102	130	154	$\mu\text{A}$	12 k $\Omega$ from VS to GND.
Open pin turn-off	$V_{VSOVFFB}$	2.64	2.7	2.76	V	
Voltage for restart after overvoltage turn-off	$V_{VSOVONFB}$	2.54	2.6	2.66	V	
ADC lower current limit	$-I_{VSADCmin}$	166	210	260	$\mu\text{A}$	For maximum on-time during operation.
ADC upper current limit	$-I_{VSADCmax}$	500	610	720	$\mu\text{A}$	For minimum on-time in burst mode.

4.3.4 Input voltage detection

Table 8 Electrical characteristics

Parameter	Symbol	Values			Unit	Note or test condition
		Min.	Typ.	Max.		
Hysteresis of brownin and brownout	$\Delta V_{BI-BO}$	–	210	–	mV	RUN state and not in burst mode. DC threshold after internal averaging.

(table continues...)

4 Electrical characteristics and parameters

Table 8 (continued) Electrical characteristics

Parameter	Symbol	Values			Unit	Note or test condition
		Min.	Typ.	Max.		
Brownin voltage level	$V_{BI}$	0.60	0.65	0.70	V	DC threshold after internal averaging.
VIN pin short to GND threshold	$V_{VINshort}$	150	200	250	mV	
VIN overvoltage threshold	$V_{VINOV}$	1.9	2.0	2.1	V	

4.3.5 TD configuration

Table 9 Electrical characteristics

Parameter	Symbol	Values			Unit	Note or test condition
		Min.	Typ.	Max.		
Internal pull-up resistor for pre-start-up $R_{TD}$ measurement	$R_{TD,flyback}$	32	40	48	k $\Omega$	Internal voltage 3.3 V.
Internal pull-up resistor for RUN state and pre-start-up $R_{TD}$ measurement	$R_{TD,RUN}$	8	10	12	k $\Omega$	Internal voltage 3.3 V. Pull-up is disabled in burst mode if VCC wake-up is triggered from $V_{VCC} \leq V_{VCCwake}$ , until $V_{VCC}$ reaches $V_{VCCburst}$ .
TD pin resistance to ground, for THD correction gain configuration and to activate VS pin load current sensing for output regulation	$R_{TD}$	27	–	68	k $\Omega$	Internal voltage 3.3 V. Minimum value based on Internal pull-up resistor of $R_{TD,RUN}$ . Maximum value based on internal pull-up resistor of $R_{TD,flyback}$ . Measured in pre-start-up phase.

4.3.6 Current sense

Table 10 Electrical characteristics

Parameter	Symbol	Values			Unit	Note or test condition
		Min.	Typ.	Max.		
OCP1 turn-off threshold	$V_{OCP1}$	570	610	650	mV	
OCP1 leading-edge blanking time	$t_{LEB}$	–	160	–	ns	
OCP2 turn-off threshold	$V_{OCP2}$	1140	1210	1260	mV	
OCP2 trigger time	$t_{OCP2}$	–	150	–	ns	Pulse width when $V_{CS} > V_{OCP2}$
CS pull-up current	$-I_{CSPU}$	0.5	1	1.5	$\mu$ A	

## 4 Electrical characteristics and parameters

### 4.3.7 PWM generation

**Table 11** Electrical characteristics

Parameter	Symbol	Values			Unit	Note or test condition
		Min.	Typ.	Max.		
Maximal on-time	$t_{ON\_max}$	16	20	–	$\mu s$	For $I_{ZCDclp} = 1.2$ mA, and $V_{VIN} = 0.6$ V DC after internal averaging.
Repetition time	$t_{Rep}$	47	52	60	$\mu s$	$V_{ZCD} = 0$ V
Off-time	$t_{Off}$	42	47	52.5	$\mu s$	

### 4.3.8 Gate driver

**Table 12** Electrical characteristics

Parameter	Symbol	Values			Unit	Note or test condition
		Min.	Typ.	Max.		
GD source current	$-I_{source}$	125	–	–	mA	
GD sink current	$I_{sink}$	250	–	–	mA	
GD peak voltage	$V_{GDfull}$	10.4	11.0	11.6	V	$V_{VCC} > (V_{GDfull} + 0.5$ V) and in QRM.
Reduced GD peak voltage	$V_{GDred}$	6.5	7.0	7.5	V	$V_{VCC} > (V_{GDred} + 0.7$ V), during start-up or burst mode.

### 4.3.9 Clock oscillators

**Table 13** Electrical characteristics

Parameter	Symbol	Values			Unit	Note or test condition
		Min.	Typ.	Max.		
Restart time	$t_{restart}$	–	200	–	ms	
Fast restart time	$t_{restart,fast}$	–	25	–	ms	Only for $V_{IN}$ under voltage (brownin protection) event

### 4.3.10 Temperature sensor

**Table 14** Electrical characteristics

Parameter	Symbol	Values			Unit	Note or test condition
		Min.	Typ.	Max.		
Relative accuracy of the temperature sensor	$\Delta T$	-6	–	+6	$^{\circ}C$	
Shutdown temperature	$T$	–	130	–	$^{\circ}C$	

5 Package dimensions

5 Package dimensions

The package dimensions of PG-DSO-8 are provided.

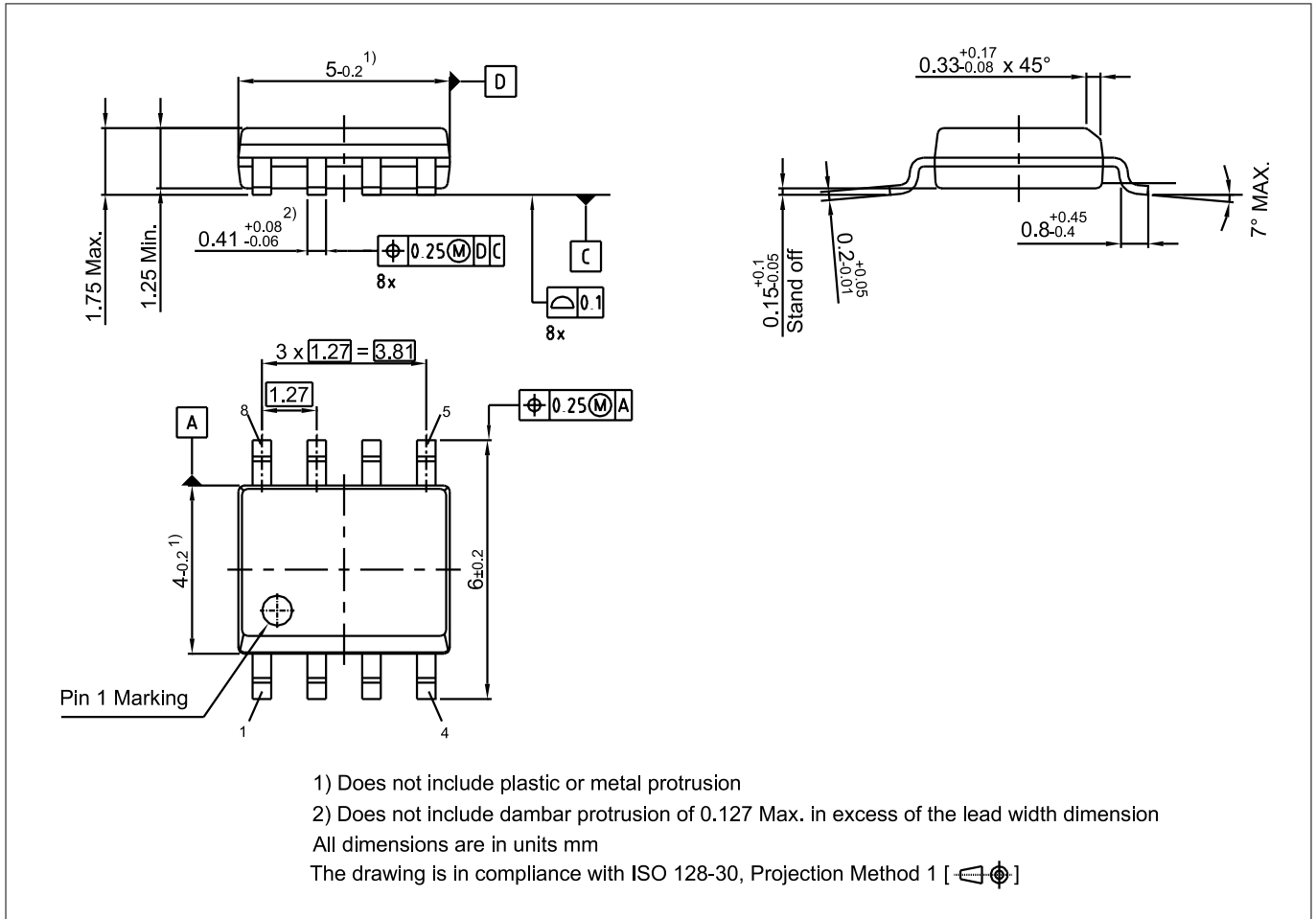
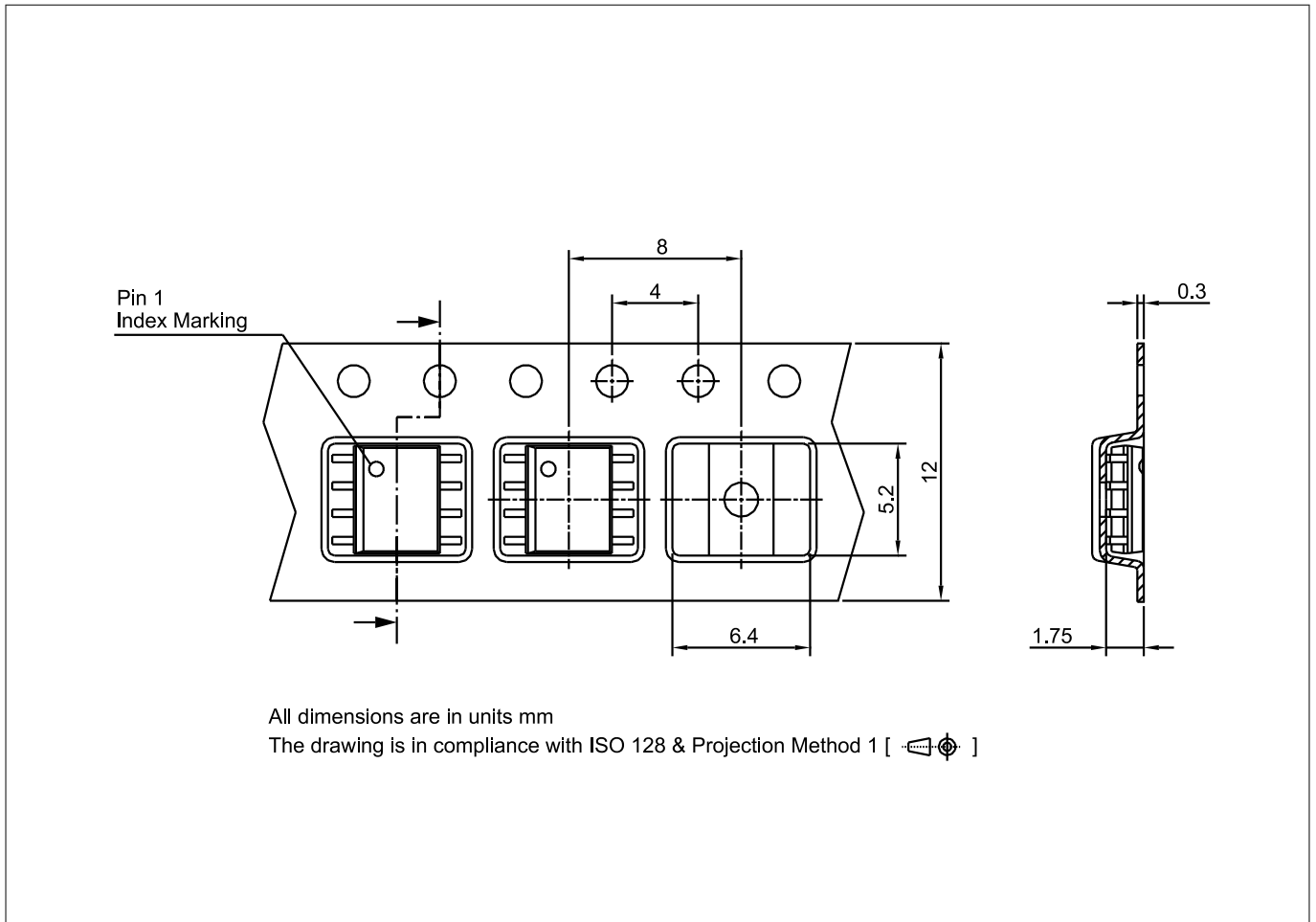

Figure 22 Package dimensions for PG-DSO-8

5 Package dimensions



**Figure 23** Tape and reel for PG-DSO-8

*Note:* You can find all of our packages, packing types and other package information on our Infineon Internet page “Products”: <http://www.infineon.com/products>.

**Green Product (RoHS compliant)**

To meet the world-wide customer requirements for environmentally friendly products and to be compliant with government regulations the device is available as a green product. Green products are RoHS-Compliant (i.e Pbfree finish on leads and suitable for Pb-free soldering according to IPC/JEDEC J-STD-020). Further information on packages: <https://www.infineon.com/packages>



**6 Glossary**

**6 Glossary**

AC	Alternating current
ADC	Analog-to-digital converter
BM	Burst mode
CV	Constant voltage
CCM	Continuous conduction mode
DC	Direct current
DCM	Discontinuous conduction mode
EMI	Electromagnetic interference
ESD	Electrostatic discharge
LED	Light emitting diode
OCP	Overcurrent protection
OTP	Overtemperature protection
OVP	Overvoltage protection
PF	Power factor
PFC	Power factor correction
PSR	Primary side regulated
QR	Quasi-resonant
QRM	Quasi-resonant mode
SSR	Secondary side regulation
THD	Total harmonic distortion
UVLO	Under voltage lockout unit

7 Revision history

7 Revision history

Revision	Date	Changes
2.0	2022-06-28	<ul style="list-style-type: none"> <li>Updated explanatory text in <a href="#">Features</a>, <a href="#">Potential applications</a>, <a href="#">Description</a> and <a href="#">Table 1</a></li> <li>Added column and information for product marking in <a href="#">Table 1</a></li> <li>Updated explanatory text and figures in <a href="#">Functional description</a></li> <li>Re-ordered section numbering in <a href="#">Functional description</a></li> <li>Corrected fault matrix in <a href="#">Table 2</a></li> <li>Added information of Green Product (RoHs compliant) in <a href="#">Package dimensions</a></li> <li>Corrected symbol of <math>V_{CC}</math> to <math>V_{VCC}</math> in <a href="#">Chapter 4</a></li> <li>Corrected <math>T_J</math> maximum value in <a href="#">Table 4</a></li> <li>Corrected <math>V_{VCC}</math> minimum and maximum value in <a href="#">Table 4</a></li> <li>Shifted <math>I_{ZCDclp}</math> from <a href="#">Table 6</a> to <a href="#">Table 4</a>, with improved parameter description and note description</li> <li>Improved parameter description of <math>V_{VCCclamp}</math> in <a href="#">Table 5</a></li> <li>Corrected note description of <math>n_{ZCDOVP}</math> in <a href="#">Table 6</a></li> <li>Added note in <a href="#">Chapter 4.3.3</a></li> <li>Removed "recommended" from note description of <math>-I_{VSSink}</math> in <a href="#">Table 7</a></li> <li>Editorial correction on note description of <math>-I_{VSADcmin}</math> and <math>-I_{VSADcmax}</math> in <a href="#">Table 7</a></li> <li>Added <math>f_{line}</math> in <a href="#">Table 4</a></li> <li>Replaced <math>V_{BO}</math> with <math>\Delta V_{BI-BO}</math> and its corresponding parameter description in <a href="#">Table 8</a></li> <li>Removed minimum and maximum value of <math>\Delta V_{BI-BO}</math> from <a href="#">Table 8</a></li> <li>Added "RUN state and not in burst mode." in note description of <math>\Delta V_{BI-BO}</math> in <a href="#">Table 8</a></li> <li>Editorial correction on the parameter description of <math>V_{BI}</math> and <math>V_{VINOV}</math> in <a href="#">Table 8</a></li> <li>Corrected minimum, typical and maximum values of <math>V_{BI}</math> in <a href="#">Table 8</a></li> <li>Corrected chapter title from "THD configuration" to "TD configuration" in <a href="#">Chapter 4.3.5</a></li> <li>Improved parameter description of <math>R_{TD,flyback}</math> and <math>R_{TD}</math> in <a href="#">Table 9</a></li> <li>Improved note description of <math>R_{TD}</math> in <a href="#">Table 9</a></li> <li>Added <math>R_{TD,RUN}</math> in <a href="#">Table 9</a></li> <li>Removed <math>V_{TD,low}</math> and <math>V_{TD,high}</math> from <a href="#">Table 9</a></li> <li>Corrected typical value of <math>t_{LEB}</math> in <a href="#">Table 10</a></li> <li>Removed minimum and maximum value of <math>t_{LEB}</math> from <a href="#">Table 10</a></li> <li>Removed <math>t_{CSOff}</math> from <a href="#">Table 10</a></li> <li>Removed "no production test" from note description of <math>t_{LEB}</math> and <math>t_{OCP2}</math> in <a href="#">Table 10</a></li> <li>Removed <math>t_{ON\_initial}</math> and <math>t_{ON\_min}</math> from <a href="#">Table 11</a></li> <li>Removed footnote of <math>t_{ON\_max}</math> and <math>t_{Rep}</math> from <a href="#">Table 11</a></li> <li>Removed "not tested in production" from note description of <math>t_{ON\_max}</math>, <math>t_{Rep}</math> and <math>t_{Off}</math> in <a href="#">Table 11</a></li> <li>Removed note description of <math>-I_{source}</math> and <math>-I_{sink}</math> from <a href="#">Table 12</a></li> <li>Changed symbol of <math>V_{GD}</math> to <math>V_{GDfull}</math> in <a href="#">Table 12</a></li> <li>Improved parameter description and note description of <math>V_{GDfull}</math> and <math>V_{GDred}</math> in <a href="#">Table 12</a></li> </ul>

---

7 Revision history

Revision	Date	Changes
		<ul style="list-style-type: none"><li>• Added "(brownin protection)" in note description of <math>t_{\text{restart,fast}}</math> in <a href="#">Table 13</a></li><li>• Removed note description of <math>t_{\text{restart}}</math> and <math>t_{\text{restart,fast}}</math> from <a href="#">Table 13</a></li><li>• Improved parameter description of <math>T</math> in <a href="#">Table 14</a></li></ul>
1.0	2021-03-17	Initial release

## Trademarks

All referenced product or service names and trademarks are the property of their respective owners.

**Edition 2022-06-28**

**Published by**

**Infineon Technologies AG**

**81726 Munich, Germany**

**© 2022 Infineon Technologies AG**

**All Rights Reserved.**

**Do you have a question about any aspect of this document?**

**Email: [erratum@infineon.com](mailto:erratum@infineon.com)**

**Document reference**

**IFX-ksh1514880840764**

## Important notice

The information given in this document shall in no event be regarded as a guarantee of conditions or characteristics ("Beschaffheitsgarantie").

With respect to any examples, hints or any typical values stated herein and/or any information regarding the application of the product, Infineon Technologies hereby disclaims any and all warranties and liabilities of any kind, including without limitation warranties of non-infringement of intellectual property rights of any third party.

In addition, any information given in this document is subject to customer's compliance with its obligations stated in this document and any applicable legal requirements, norms and standards concerning customer's products and any use of the product of Infineon Technologies in customer's applications.

The data contained in this document is exclusively intended for technically trained staff. It is the responsibility of customer's technical departments to evaluate the suitability of the product for the intended application and the completeness of the product information given in this document with respect to such application.

## Warnings

Due to technical requirements products may contain dangerous substances. For information on the types in question please contact your nearest Infineon Technologies office.

Except as otherwise explicitly approved by Infineon Technologies in a written document signed by authorized representatives of Infineon Technologies, Infineon Technologies' products may not be used in any applications where a failure of the product or any consequences of the use thereof can reasonably be expected to result in personal injury.