

REVISIONS

P	LTR	DESCRIPTION	DATE	DWN	APVD
	A	INITIAL RELEASE	17JUN2020	J.G	I.Y
	A1	ECR-20-010349	26JUL2020	J.G	I.Y
	A2	ECN-21-113425	17AUG2021	J.G	Z.Z

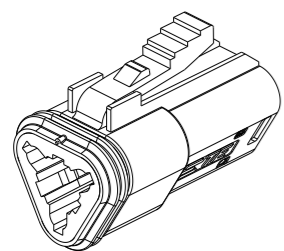

3CCT PLUG CONNECTOR WITHOUT HEATSHRINK HOUSING

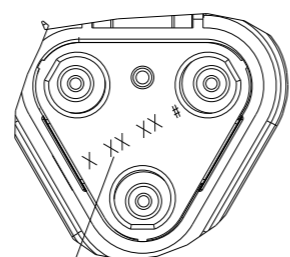

DETAIL A SCALE 2:1

4 DATE CODE: X XX XX
X- DAY: 1- 7

XX- WEEK: 01 - 52

XX- YEAR: 00 - 99

#- MACHINE NO. 1

EXAMPLE: 11315 = DAY 1, WEEK 13, YEAR 15 i.e. 23rd OF MARCH 2015

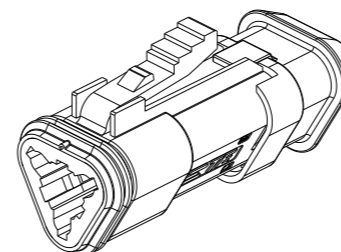
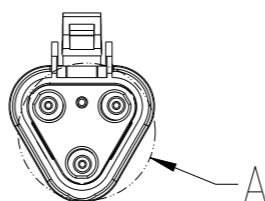
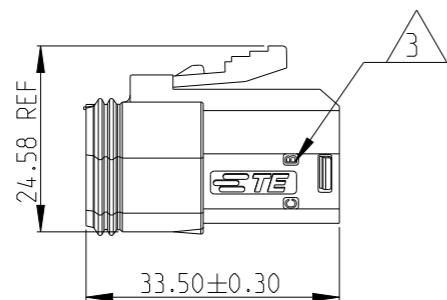
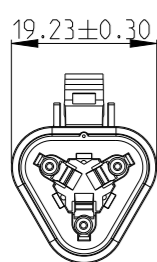

3CCT PLUG CONNECTOR WITH HEATSHRINK HOUSING ULTRA SONICALLY WELDED IN PLACE

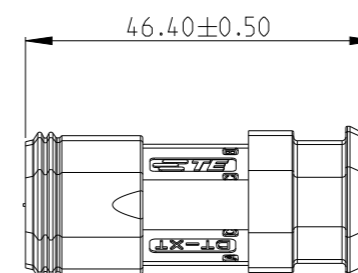
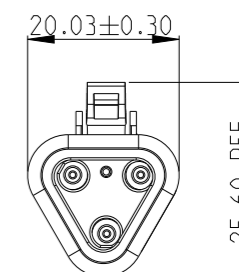
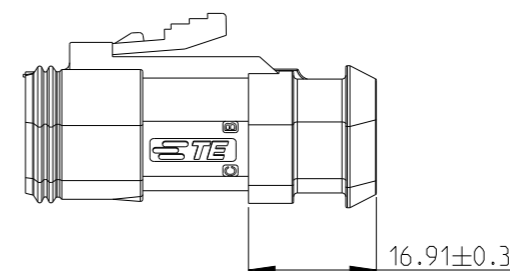
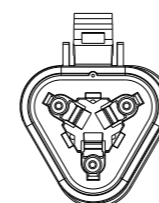

1. THIS PLUG MATES WITH RECEPTACLE ASSEMBLY PN X-2600026-X, WEDGE LOCK PN W3SX.

2. MATERIALS
 PLUG HOUSING: NYLON GF30, SEE PN TABLE FOR COLOUR; PLUG SEAL: SILICONE RUBBER, RED
 BACK SEAL: SILICONE RUBBER
 BACK COVER: NYLON GF30, BLACK
 HEATSHRINK HOUSING: NYLON GF30, BLACK

3 CIRCUIT IDENTIFICATION

4 DATE CODE DESCRIPTION

5. JACKET RANGE LARGE = Ø2.23MM TO 3.68MM (SEAL COLOUR: LIGHT BLUE)
 JACKET RANGE SMALL = Ø1.20MM TO 3.05MM (SEAL COLOUR: BURNT ORANGE)

6. SEE SHEET 2 FOR FINAL PART NUMBER

THIS DRAWING IS A CONTROLLED DOCUMENT.

DIMENSIONS:	TOLERANCES UNLESS OTHERWISE SPECIFIED:
mm	
	0 PLC ±
	1 PLC ±
	2 PLC ±
	3 PLC ±
	4 PLC ±
	ANGLES ±
MATERIAL -	FINISH -

DWN	J.GU	17JUN2020
CHK	E. JIANG	17JUN2020
APVD	I.YIN	17JUN2020
PRODUCT SPEC	108-160026	
APPLICATION SPEC	114-160017	
WEIGHT	-	



NAME 3CCT DT-XT CONNECTOR PLUG ASSEMBLY

SIZE	CAGE CODE	DRAWING NO	RESTRICTED TO
A3	00779	C=2600027	-

THIS DRAWING IS UNPUBLISHED.

RELEASED FOR PUBLICATION

20

REVISIONS

© COPYRIGHT 2020 TE Connectivity. All Rights Reserved.

ALL RIGHTS RESERVED.

P	LTR	DESCRIPTION	DATE	DWN	APVD
		SEE SHEET 1			

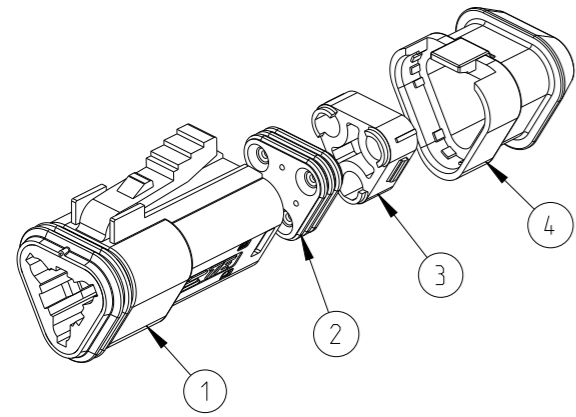

3--6	934452609	-	8.26
3--5	934452608	-	8.26
3--4	934452607	-	8.26
3--3	934452606	-	8.26
3--2	934452605	-	8.26
3--1	934452604	-	8.26
3--0	934452603	-	8.26
2--9	934452602	-	8.26
2--8	934452601	-	8.26
2--7	934452509	-	8.26
2--6	934452508	-	8.26
2--5	934452507	-	8.26
2--4	934452506	-	8.26
2--3	934452505	-	8.26
2--2	934452504	-	8.26
2--1	934452503	-	8.26
2--0	934452502	-	8.26
1--9	934452501	-	8.26
1--8	934452209	-	6.22
1--7	934452208	-	6.22
1--6	934452207	-	6.22
1--5	934452206	-	6.22
1--4	934452205	-	6.22
1--3	934452204	-	6.22
1--2	934452203	-	6.22
1--1	934452202	-	6.22
1--0	934452201	-	6.22
-9	934452109	-	6.22
-8	934452108	-	6.22
-7	934452107	-	6.22
-6	934452106	-	6.22
-5	934452105	-	6.22
-4	934452104	-	6.22
-3	934452103	-	6.22
-2	934452102	-	6.22
-1	934452101	-	6.22

QTY. REQUEST PER ASSY

-	-	-	-	-	-	-	-	-	-	1	-	1	1	1
-	-	-	-	-	-	-	-	-	1	-	-	1	1	1
-	-	-	-	-	-	-	-	1	-	-	-	1	1	1
-	-	-	-	-	-	1	-	-	-	-	-	1	1	1
-	-	-	-	1	-	-	-	-	-	-	-	1	1	1
-	-	1	-	-	-	-	-	-	-	-	-	1	1	1
-	1	-	-	-	-	-	-	-	-	-	-	1	1	1
1	-	-	-	-	-	-	-	-	-	-	1	1	1	1
-	-	-	-	-	-	-	-	-	1	-	1	-	1	1
-	-	-	-	-	-	-	-	-	1	-	1	-	1	1
-	-	-	-	-	-	-	-	-	1	-	1	-	1	1
-	-	-	-	1	-	-	-	-	-	-	1	-	1	1
-	-	1	-	-	-	-	-	-	-	-	1	-	1	1
-	1	-	-	-	-	-	-	-	-	-	1	-	1	1
1	-	-	-	-	-	-	-	-	-	-	1	-	1	1
-	-	-	-	-	-	-	-	-	-	1	-	1	1	-
-	-	-	-	-	-	-	-	-	-	1	-	1	1	-
-	-	-	-	-	-	-	-	-	-	-	1	-	1	-
-	-	-	-	-	-	-	-	-	-	-	-	1	1	-
-	-	-	-	-	-	-	-	-	-	-	-	1	1	-
-	-	-	-	-	-	-	-	-	-	-	-	-	1	-
-	-	-	-	-	-	-	-	-	-	-	-	-	-	1
-	-	-	-	-	-	-	-	-	-	-	-	-	-	-
-	-	-	-	-	-	-	-	-	-	-	-	-	-	-
-	-	-	-	-	-	-	-	-	-	-	-	-	-	-
-	-	-	-	-	-	-	-	-	-	-	-	-	-	-
-	-	-	-	-	-	-	-	-	-	-	-	-	-	-
-	-	-	-	-	-	-	-	-	-	-	-	-	-	-
-	-	-	-	-	-	-	-	-	-	-	-	-	-	-
-	-	-	-	-	-	-	-	-	-	-	-	-	-	-
-	-	-	-	-	-	-	-	-	-	-	-	-	-	-
-	-	-	-	-	-	-	-	-	-	-	-	-	-	-
-	-	-	-	-	-	-	-	-	-	-	-	-	-	-
-	-	-	-	-	-	-	-	-	-	-	-	-	-	-
-	-	-	-	-	-	-	-	-	-	-	-	-	-	-
-	-	-	-	-	-	-	-	-	-	-	-	-	-	-
-	-	-	-	-	-	-	-	-	-	-	-	-	-	-
-	-	-	-	-	-	-	-	-	-	-	-	-	-	-
-	-	-	-	-	-	-	-	-	-	-	-	-	-	-
-	-	-	-	-	-	-	-	-	-	-	-	-	-	-
-	-	-	-	-	-	-	-	-	-	-	-	-	-	-

TE PN	ALIAS PN	REVISION OF EACH ASSY NO.	WEIGHT OF EACH ASSY(g)	COLOR	BLACK	GERY	GREEN	BLUE	YELLO W	WHIT E	BROW N	ORANG E	RED	BURNT ORANGE	LIGHT BLUE	BLACK	BLACK		
					NYLON GF30	NYLON GF30	NYLON GF30	NYLON GF30	NYLON GF30	NYLON GF30	NYLON GF30	NYLON GF30	NYLON GF30	SILICONE RUBBER	SILICONE RUBBER	NYLON GF30	NYLON GF30		
					PLUG HOUSING											BACK SEAL SMALL	BACK SEAL LARGE	BACK COVER	HEATSHRINK HOUSING
					1											2		3	4

THIS DRAWING IS A CONTROLLED DOCUMENT.

DIMENSIONS: mm	TOLERANCES UNLESS OTHERWISE SPECIFIED:
	0 PLC ±
	1 PLC ±
	2 PLC ±
	3 PLC ±
	4 PLC ±
	ANGLES ±
MATERIAL	FINISH

DWN	J.GU	17 JUN 2020
CHK	E. JIANG	17 JUN 2020
APVD	L. YIN	17 JUN 2020
PRODUCT SPEC	108-160026	
APPLICATION SPEC	114-160017	
WEIGHT	-	

STE TE Connectivity

NAME: 3CCT DT-XT CONNECTOR PLUG ASSEMBLY

SIZE: A3 CAGE CODE: 00779 DRAWING NO: C=2600027 RESTRICTED TO: -

CUSTOMER DRAWING; RESTRICTED CUSTOMER SCALE: 1:1 SHEET: 2 OF 2 REV: A2