

# Customer Information Sheet

DRAWING No.: M80-5L11000-03-333

SHEET 2 OF 2

IF IN DOUBT - ASK

©

NOT TO SCALE

THIRD ANGLE PROJECTION

ALL DIMENSIONS IN mm

## OBSOLETE

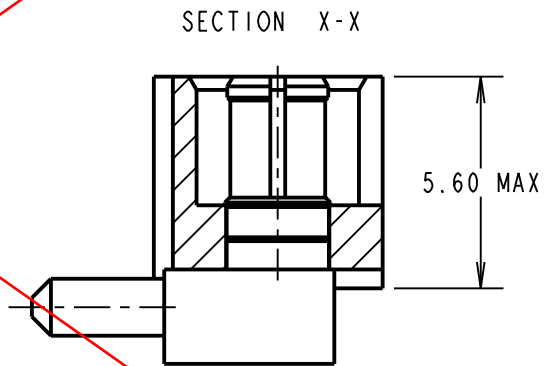
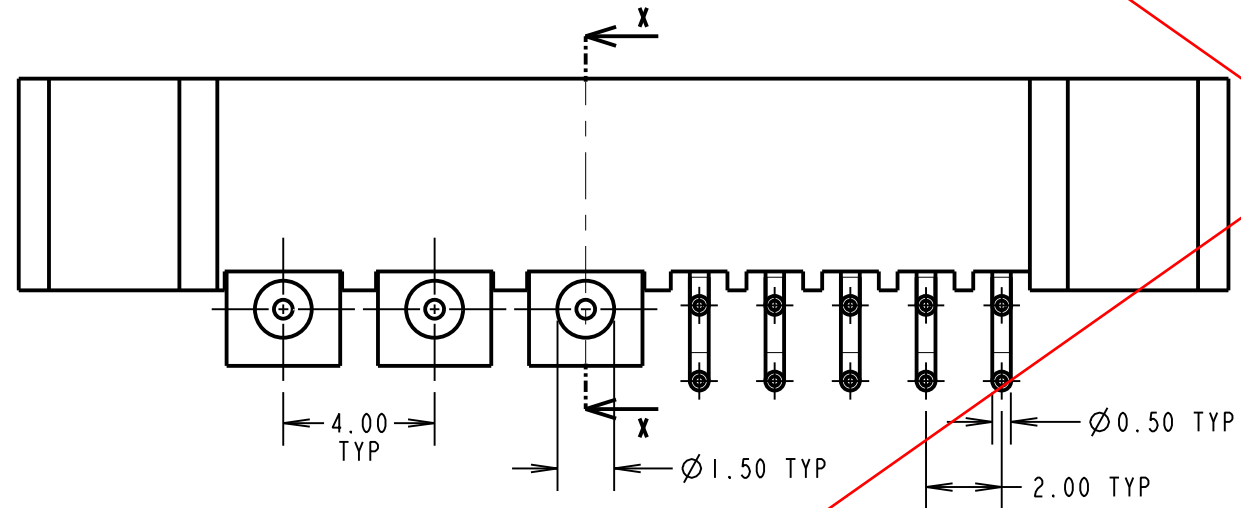
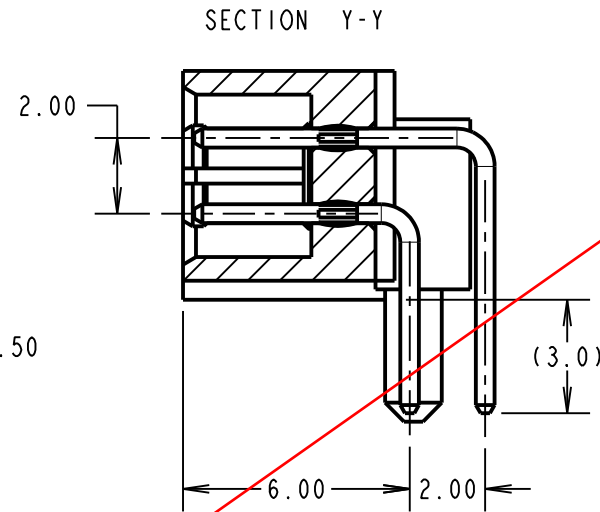
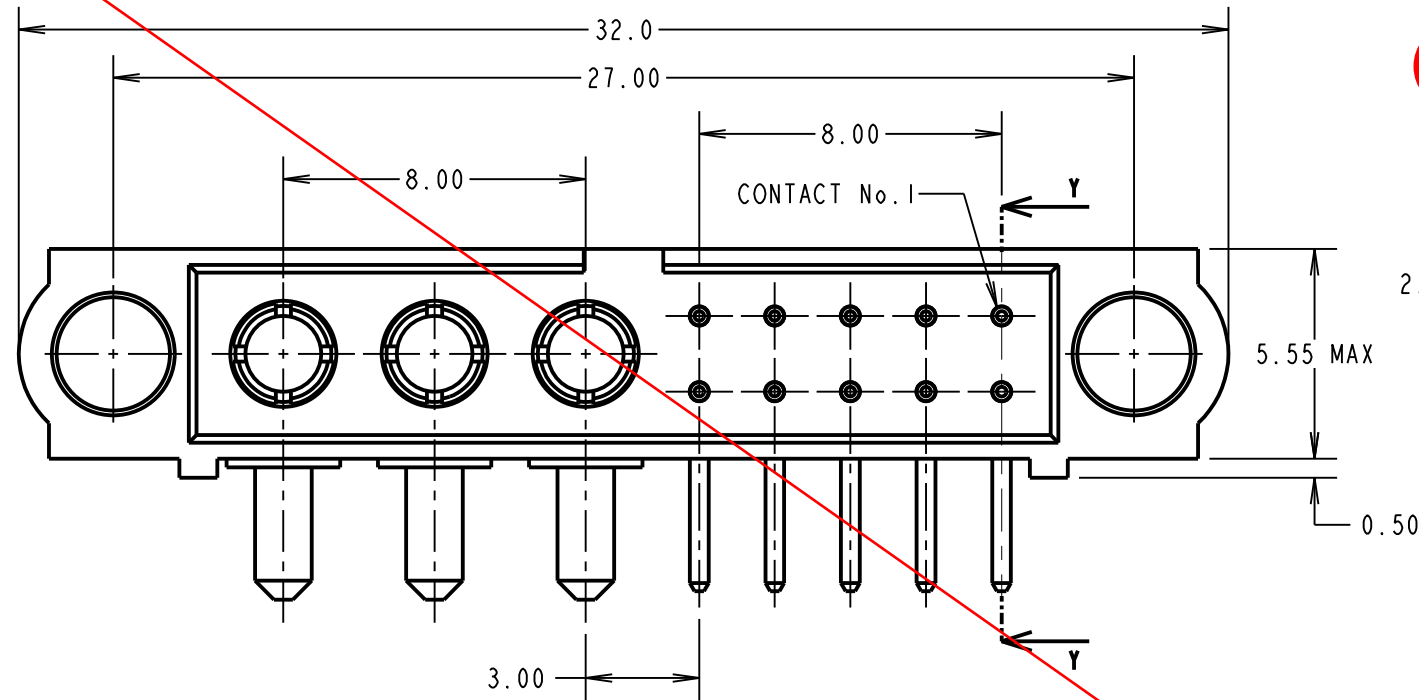

RECOMMENDED PCB LAYOUT

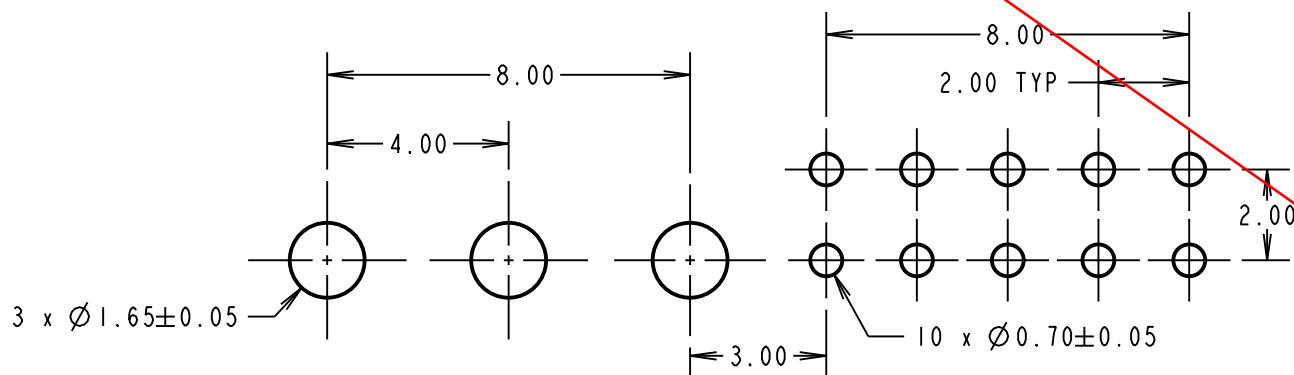

**SPECIFICATIONS:**  
**MATERIAL:**  
 MOULDING = GLASS-FILLED PPS, UL94V-0, BLACK  
 SIGNAL PIN = PHOSPHOR BRONZE  
 POWER CONTACT = COPPER ALLOY  
**FINISH:**  
 SIGNAL PIN = 0.75µ GOLD ON CONTACT AREA,  
 3µ 100% TIN OVER NICKEL ON TAILS  
 POWER CONTACT = GOLD  
**ELECTRICAL:**  
**SIGNAL CONTACT:**  
 CURRENT RATING AT 25°C = 3.0A MAX  
 CURRENT RATING AT 85°C = 2.2A MAX  
 CONTACT RESISTANCE = 25mΩ MAX  
**POWER CONTACT:**  
 CURRENT RATING = 20A MAX  
 CONTACT RESISTANCE = 6mΩ MAX  
 WORKING VOLTAGE = 800V AC/DC  
 VOLTAGE PROOF = 1200V AC/DC  
 INSULATION RESISTANCE = 100MΩ MIN  
**MECHANICAL:**  
 DURABILITY = 500 OPERATIONS  
**ENVIRONMENTAL:**  
 TEMPERATURE RANGE = -55°C TO +125°C  
**PACKING:**  
 TUBE  
 FOR COMPLETE SPECIFICATION, SEE COMPONENT SPECIFICATION C005XX (LATEST ISSUE)

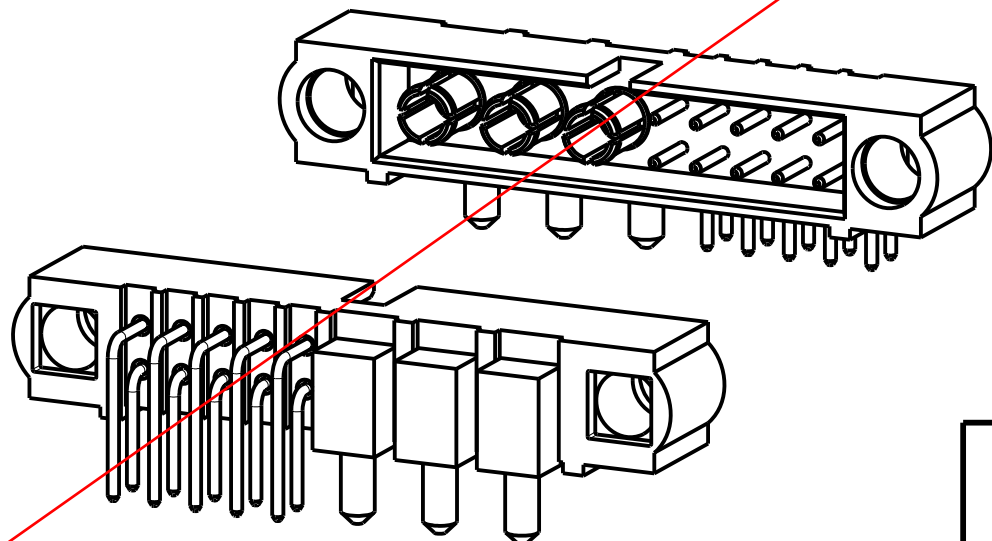

LS	2	19.10.17	13269
NAME	ISS.	DATE	C/NOTE
APPROVED: LS			
CHECKED: MGP			
DRAWN: B. M. KENT			
CUSTOMER REF.:			
ASSEMBLY DRG:			

## HARWIN

www.harwin.com  
 technical@harwin.com

THIS DRAWING AND ANY INFORMATION OR DESCRIPTIVE MATTER SET OUT HEREON ARE CONFIDENTIAL AND COPYRIGHT PROPERTY OF THE HARWIN GROUP AND MUST NOT BE DISCLOSED, LOANED, COPIED OR USED FOR MANUFACTURING, TENDERING OR FOR ANY OTHER PURPOSE WITHOUT THEIR WRITTEN PERMISSION.

**TOLERANCES**  
 X. = ±1mm  
 X.X = ±0.50mm  
 X.XX = ±0.10mm  
 X.XXX = ±0.01mm  
**ANGLES = ±5°**  
**UNLESS STATED**

**MATERIAL:**

SEE ABOVE

**FINISH:**

SEE ABOVE

**S/AREA:**

mm<sup>2</sup>

**TITLE:** JACKSCREW DATAMATE  
 MIXED TECHNOLOGY HORIZONTAL  
 PC TAIL MALE ASSEMBLY

**DRAWING NUMBER:**

**M80-5L11000-03-333**

SHT  
 2 OF 2