

PROPER USE GUIDELINES

Cumulative Trauma Disorders can result from the prolonged use of manually powered hand tools. Hand tools are intended for occasional use and low volume applications. A wide selection of powered application equipment for extended-use, production operations is available.

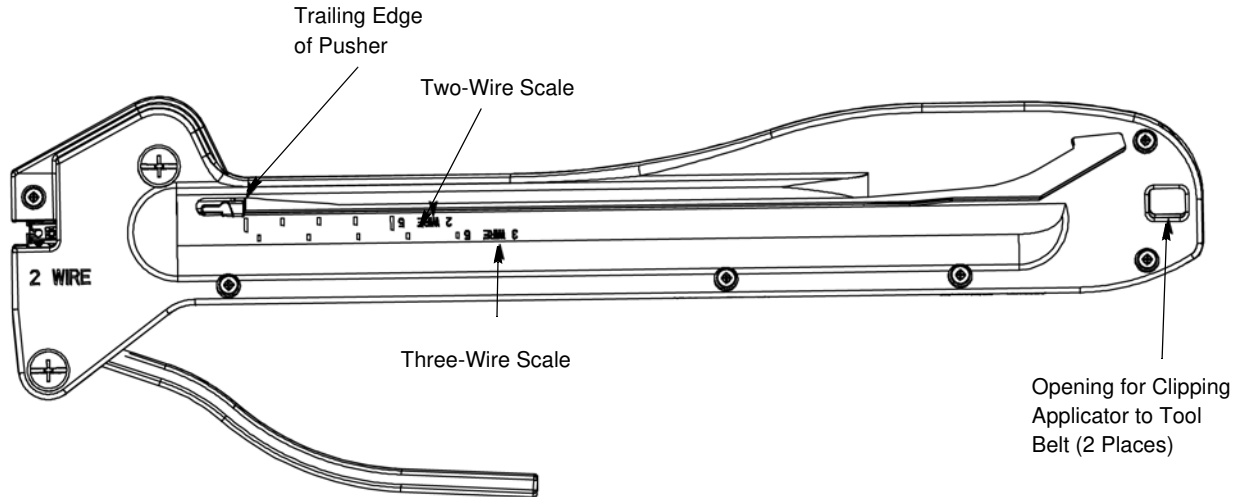

Figure 1

1. INTRODUCTION

Two-wire (gray) Tel-Splice Applicator 1490017-1 (shown in Figure 1) is designed to terminate two-wire Tel-Splice Sticks 1389031-1 and -2, Half-Tap Sticks 1389030-1, -2, and -3, and Clearing Splice Stick 1479842-1. Three-wire (black) Tel-Splice Applicator 1490018-1 is designed to terminate three-wire Tel-Splice Sticks 1389032-1 and -2. Tel-Splice Applicator Kit 1583100-1 consists of both applicators.



All numerical values in this document are in metric units [with U.S. customary units in brackets].

The physical working environment for each applicator is 49° to -23°C [120° to -10°F].

Reasons for reissue of this instruction sheet are provided in Section 6, REVISION SUMMARY.

2. DESCRIPTION

This hand-held, hand-actuated applicator will apply ultrasonically welded stick products used in the telecommunication industry. The applicator has an ergonomically designed thermoplastic body that provides a high strength, lightweight, non-repairable applicator, which allows for the sticks to be easily loaded, feeding connectors forward under the crimp jaw for termination.

These applicators have built in scales which help to identify the last five connectors remaining in the applicator. Refer to Figure 1. When using this scale be

sure to relate the trailing edge of the pusher with proper scale. For example, reference the two-wire scale when using the gray applicator, and reference the three-wire scale when using the black applicator.

At the back of the applicator a rectangular opening is molded into each side of the applicator. This opening provides the crafts person with a method of clipping the applicator to a tool belt. Refer to Figure 1.

3. OPERATION

1. Retract and latch the pusher assembly. Load a stick, orienting the parts to the keyed track in the applicator. See Figure 2.
2. Before unlatching the pusher, verify that the connectors are forward of the arrow in the "sight window," which is an integral part of the gage slots (described in Section 4).

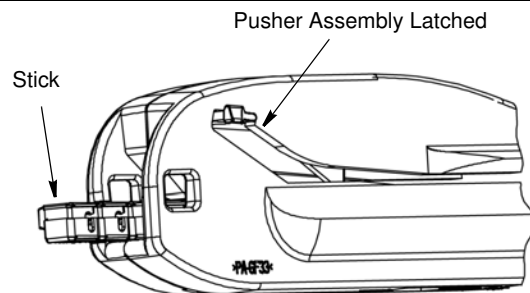



Figure 2

3. When the end of the stick is visible in the “sight window,” the pusher assembly may be unlatched. This will advance all the parts forward, locating the first connector in the stick under the crimp jaw.

4. Insert wires into the connector according to the applicable connector application specification (114-series). Refer to Figure 3. Close applicator handle until the connector cover is seated on the top of the connector housing flange.

NOTE
 It is not necessary to squeeze the handle until it touches the outside of the applicator shell to get a good crimp.

5. When the handle is released, the applicator automatically ejects the terminated connector while positioning a new connector for termination.

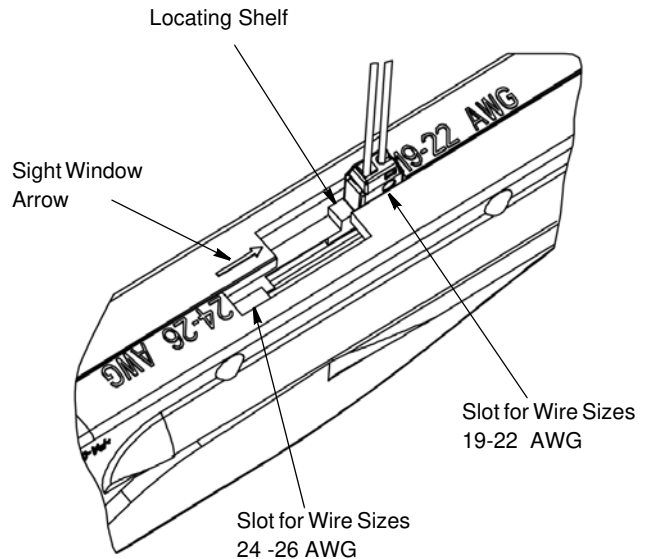

Figure 4

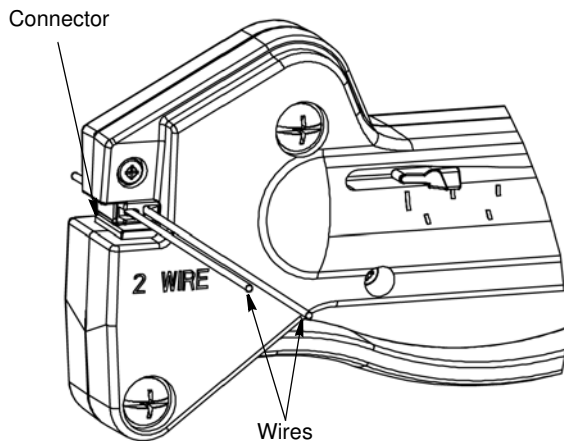



Figure 3

4. GAGING THE CONNECTOR (Figure 4)

Verify that the termination is good according to the following:

1. Place the terminated connector in the proper gage slot (slots are identified by wire size) located on the handle side of the applicator.
2. Determine the largest wire size terminated and select the gage slot marked with the applicable wire size. Insert the terminated connector in the large opening, sliding the connector into the appropriate gage slot (with little or no drag) with the end resting on the locating shelf. If excessive drag is apparent, it will be necessary to close the applicator handle tighter for future terminations.

NOTE
 Failed connector assemblies can be repaired with a loose-piece terminating tool such as Terminating Tool 231839-1. For operating procedure, refer to 408-3183.

5. DAILY MAINTENANCE

The applicator is a non-repairable device that should not require disassembly. When not in use, the applicator should be stored in a clean dry place.

Remove dirt, moisture, foreign matter and any build-up of connector sealant with a clean brush or soft, lint-free cloth. DO NOT use hard or abrasive objects that could damage the applicator.

NOTE
 The following cleaner is recommended:
 Cleaner Plus (Product 87041)
 Rainbow Technology
 261 Cahaba Valley Parkway
 Pelham, AL 35124-1146

6. REVISION SUMMARY

Revisions to this instruction sheet include:

- Changed company name and logo