

Gas Gauge IC With SMBus-Like Interface

Features

- Provides conservative and repeatable measurement of available charge in NiCd, NiMH, and Lithium Ion rechargeable batteries
- Designed for battery pack integration
 - 120µA typical operating current
 - Small size enables implementations in as little as ½ square inch of PCB
- Two-wire SMBus-like interface
- Measurements compensated for current and temperature
- Contains self-discharge compensation using internal temperature sensor
- 16-pin narrow SOIC

General Description

The bq2090 Gas Gauge IC With SMBus-like Interface is intended for battery-pack or in-system installation to maintain an accurate record of available battery charge. The bq2090 directly supports capacity monitoring for NiCd, NiMH, and Lithium Ion battery chemistries.

The bq2090 uses the SMBus protocol that supports many of the Smart Battery Data (SBDData) commands. Battery state-of-charge, capacity remaining, remaining time and chemistry are available over the serial link. Battery-charge state can be directly indicated using a four-segment LED display to graphically depict battery full-to-empty in 25% increments.

The bq2090 estimates battery self-discharge based on an internal timer and temperature sensor. The bq2090 also automatically recalibrates, or "learns" battery capacity in the full course of a discharge cycle from full to empty.

The bq2090 may operate directly from three or four nickel chemistry cells. With the REF output and an external transistor, a simple, inexpensive regulator can be built to provide V_{CC} for other battery cell configurations.

An external E²PROM is used to program initial values into the bq2090 and is necessary for proper operation.

Pin Connections

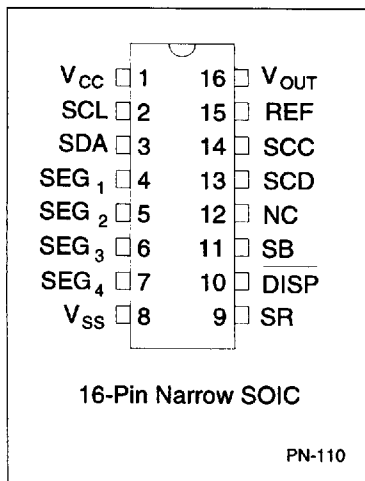

Pin Names

V _{OUT}	E ² PROM supply output	SB	Battery sense input
SEG ₁	LED segment 1	$\overline{\text{DISP}}$	Display control input
SEG ₂	LED segment 2	SR	Sense resistor input
SEG ₃	LED segment 3	SCC	Serial communication clock
SEG ₄	LED segment 4	SCD	Serial communication data input/output
SCL	Serial memory clock	V _{CC}	3.0–5.5V
SDA	Serial memory data	V _{SS}	System ground
REF	Voltage reference output		

bq2090

Pin Descriptions

SEG₁- SEG₄	LED display segment outputs Each output may activate an external LED to sink the current sourced from V _{CC} .	SR	Sense resistor input The voltage drop (V _{SR}) across pins SR and V _{SS} is monitored and integrated over time to interpret charge and discharge activity. The SR input is connected to the sense resistor and the negative terminal of the battery. V _{SR} < V _{SS} indicates discharge, and V _{SR} > V _{SS} indicates charge. The effective voltage drop, V _{SRO} , as seen by the bq2090 is V _{SR} + V _{OS} (see Table 3).
SCC	Serial communication clock This open-drain bidirectional pin is used to clock the data transfer to and from the bq2090.	DISP	Display control input $\overline{\text{DISP}}$ high disables the LED display. $\overline{\text{DISP}}$ floating allows the LED display to be active during charge or during discharge if the rate is greater than a user-programmable threshold. DISP low activates the display.
SCD	Serial communication data This open-drain bidirectional pin is used to transfer address and data to and from the bq2090.	SB	Secondary battery input This input monitors the single-cell voltage potential through a high-impedance resistor divider network for end-of-discharge voltage (EDV) thresholds and maximum charge voltage (MCV).
SCL	Serial memory clock This output is used to clock the data transfer between the bq2090 and the external non-volatile configuration memory.	REF	Reference output for regulator REF provides a reference output for an optional micro-regulator.
SDA	Serial memory data and address This bi-directional pin is used to transfer address and data to and from the bq2090 and the external configuration memory.	V_{CC}	Supply voltage input
NC	No connect	V_{SS}	Ground
V_{OUT}	Supply output This output supplies power to the external E ² PROM configuration memory.		

Functional Description

General Operation

The bq2090 determines battery capacity by monitoring the amount of charge input to or removed from a rechargeable battery. The bq2090 measures discharge and charge currents, estimates self-discharge and monitors the battery for low-battery voltage thresholds. The charge measurement is made by monitoring the voltage across a small-value series sense resistor between the negative battery terminal and ground. The available battery charge is determined by monitoring this voltage over time and correcting the measurement for the environmental and operating conditions.

Figure 1 shows a typical battery pack application of the bq2090 using the LED capacity display, the serial port, and an external E2PROM for battery pack programming information. The bq2090 must be configured and calibrated for the battery-specific information to ensure proper operation. Table 1 outlines the externally programmable functions available in the bq2090. Refer to the Programming the bq2090 section for further details.

An internal temperature sensor eliminates the need for an external thermistor—reducing cost and components. An internal, temperature-compensated time-base eliminates the need for an external resonator, further reducing cost and components. The entire circuit in Figure 1 can occupy less than $\frac{3}{4}$ square inch of board space.

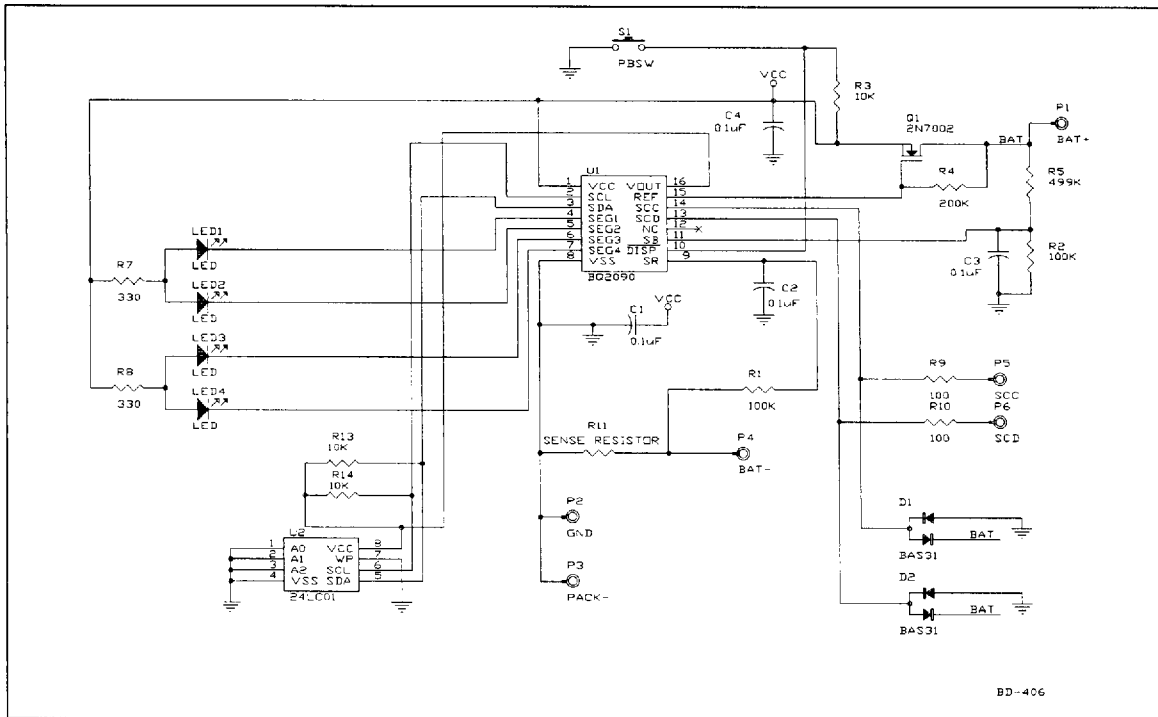

Figure 1. Battery Pack Application Diagram—LED Display

Table 1. Configuration Memory Programming Values

Parameter Name	Address	Length	Units
Design capacity	0x00/0x01	16 bits: low byte, high byte	mAh
Initial battery voltage	0x02/0x03	8 bits	N/A
Reserved	0x04/0x05	–	–
Reserved	0x06/0x07	–	–
Remaining Capacity Alarm	0x08/0x09	16 bits: low byte, high byte	mAh
FLAGS1	0x0a	8 bits	N/A
FLAGS2	0x0b	8 bits	N/A
Current measurement gain	0x0c/0x0d	16 bits: low byte, high byte	N/A
EDV ₁	0x0e/0x0f	16 bits: low byte, high byte	mV
EDV _F	0x10/0x11	16 bits: low byte, high byte	mV
Temperature offset	0x12/0x13	16 bits: low byte, high byte	0.1°K
Self-discharge rate	0x14	16 bits: low byte, high byte	N/A
Digital filter	0x15	8 bits	mV
Current integration gain	0x16/0x17	16 bits: low byte, high byte	N/A
Discharge display threshold	0x18	8 bits	N/A
Battery voltage offset	0x19	8 bits	mV
Battery voltage gain	0x1a/0x1b	16 bits	N/A
Reserved	0x1c/0x31	–	–
Design voltage	0x32/0x33	16 bits: low byte, high byte	mV
Specification Information	0x34/0x35	16 bits: low byte, high byte	N/A
Manufacturer Date	0x36/0x37	16 bits: low byte, high byte	N/A
Serial number	0x38/0x39	16 bits: low byte, high byte	N/A
Reserved	0x3a/0x3f	–	–
Manufacturer name	0x40/0x4f	8 + 120 bits	N/A
Device name	0x50/0x5f	8 + 120 bits	N/A
Chemistry	0x60/0x6f	8 + 120 bits	N/A
Manufacturer data	0x70/0x7f	8 + 120 bits	N/A

N/A=Not applicable; data packed or coded. See Programming the bq2090 section for details.

Voltage Thresholds

In conjunction with monitoring V_{SR} for charge/discharge currents, the bq2090 monitors the battery potential through the SB pin. The voltage potential is determined through a resistor divider network per the following equation:

$$\frac{R_5}{R_2} = \frac{MBV}{2.25} - 1$$

where MBV is the maximum battery voltage, R_5 is connected to the positive battery terminal, and R_2 is connected to the negative battery terminal. R_5/R_2 should be rounded to the next highest integer. The battery voltage is monitored for the end-of-discharge voltage (EDV) and for maximum cell voltage (MCV) and for alarm warning conditions. EDV threshold levels are used to determine when the battery has reached an "empty" state, and the MCV threshold is used for fault detection during charging. The battery voltage gain and two EDV thresholds are programmed via E²PROM. See the Programming the bq2090 section for further details.

If V_{SB} is below either of the two EDV thresholds, the associated flag is latched and remains latched, independent of V_{SB} , until the next valid charge.

EDV monitoring may be disabled under certain conditions. If the discharge current is greater than 3A, EDV monitoring is disabled and resumes after the current falls below 1.5A.

Reset

The bq2090 is reset when first connected to the battery pack. The bq2090 can also be reset with a command over the serial port, as described in the Software Reset section.

Temperature

The bq2090 monitors temperature using an internal sensor. The temperature is used to adapt charge/discharge and self-discharge compensations. Temperature may also be accessed over the serial port. See the Programming the bq2090 section for further details.

Layout Considerations

The bq2090 measures the voltage differential between the SR and V_{SS} pins. V_{OS} (the offset voltage at the SR pin) is greatly affected by PC board layout. For optimal results, the PC board layout should follow the strict rule of a single-point ground return. Sharing high-current ground with small signal ground causes undesirable noise on the small signal nodes. Additionally, in reference to Figure 1:

- The capacitors (C1, C3, and C4) should be placed as close as possible to the SB and V_{CC} pins, and their paths to V_{SS} should be as short as possible. A high-quality ceramic capacitor of 0.1 μ f is recommended for V_{CC} .
- The sense resistor capacitor (C2) should be placed as close as possible to the SR pin.
- The sense resistor (R_{11}) should be as close as possible to the bq2090.
- The IC should be close to the cells for the best temperature measurement.

Gas Gauge Operation

The operational overview diagram in Figure 2 illustrates the operation of the bq2090. The bq2090 accumulates a measure of charge and discharge currents, as well as an estimation of self-discharge. Charge and discharge currents are temperature-compensated, and charge is rate-compensated. Self-discharge is only temperature-compensated.

The main counter, Remaining Capacity (RM), represents the available battery capacity at any given time. Battery charging increments the RM register, whereas battery discharging and self-discharge decrement the RM register and increment the DCR (Discharge Count Register).

The Discharge-Count Register (DCR) is used to update the Full-Charge Capacity (FCC) register only if a complete battery discharge from full to empty occurs without any partial battery charges. Therefore, the bq2090 adapts its capacity determination based on the actual conditions of discharge.

The battery's initial capacity is equal to the Design Capacity (DC). Until FCC is updated, RM counts up to, but not beyond, this threshold during subsequent charges.

1. Full-Charge Capacity or learned-battery capacity:

FCC is the last measured discharge capacity of the battery. On initialization (application of V_{CC} or reset), $FCC = DC$. During subsequent discharges, the FCC is updated with the latest measured capacity in the Discharge Count Register (DCR), representing a discharge from full to below EDV1. A qualified discharge is necessary for a capacity transfer from the DCR to the FCC register. The FCC also serves as the 100% reference threshold used by the relative state-of-charge calculation and display.

2. Design Capacity (DC):

The DC is the user specified battery capacity and is programmed by using an external E²PROM. The DC also provides the 100% reference for the absolute display mode.

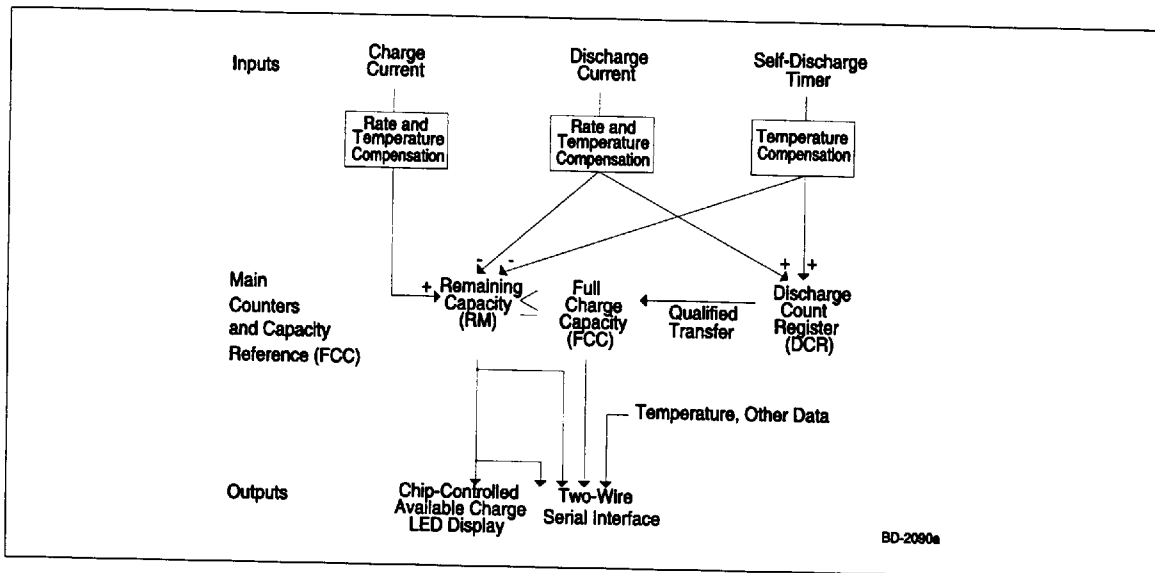

Figure 2. Operational Overview

3. Remaining Capacity (RM):

RM counts up during charge to a maximum value of FCC and down during discharge and self-discharge to 0. RM is reset to 0 on initialization and when a valid charge is detected and EDV₁=1. To prevent overstatement of charge during periods of over-charge, RM stops incrementing when RM = FCC.

4. Discharge Count Register (DCR):

The DCR counts up during discharge independent of RM and can continue increasing after RM has decremented to 0. Prior to RM = 0 (empty battery), both discharge and self-discharge increment the DCR. After RM = 0, only discharge increments the DCR. The DCR resets to 0 when RM = FCC. The DCR does not roll over but stops counting when it reaches FFFFh.

The DCR value becomes the new FCC value on the first charge after a valid discharge to V_{EDV1} if:

- No valid charge initiations (charges greater than 10mAh, where V_{SRO} > V_{SRQ}) occurred during the period between RM = FCC and EDV1 detected.
- The self-discharge count is not more than 256mAh.
- The temperature is ≥ 273°K when the EDV1 level is reached during discharge.

The valid discharge flag (VDQ) indicates whether the present discharge is valid for FCC update.

Charge Counting

Charge activity is detected based on a positive voltage on the V_{SR} input. If charge activity is detected, the bq2090 increments RM at a rate proportional to V_{SRO} and, if enabled, activates an LED display. Charge actions increment the RM after compensation for charge rate and temperature.

The bq2090 determines charge activity sustained at a continuous rate equivalent to V_{SRO} > V_{SRQ}. A valid charge equates to sustained charge activity greater than 10mAh. Once a valid charge is detected, charge counting continues until V_{SRO} falls below V_{SRQ}. V_{SRQ} is a programmable threshold as described in the Digital Magnitude Filter section.

Discharge Counting

All discharge counts where V_{SRO} < V_{SRD} cause the RM register to decrement and the DCR to increment. Exceeding the user-programmable discharge display threshold, stored in external E²PROM, activates the display, if enabled. V_{SRD} is a programmable threshold as described in the Digital Magnitude Filter section.

Self-Discharge Estimation

The bq2090 continuously decrements RM and increments DCR for self-discharge based on time and temperature. The self-discharge rate is dependent on the battery chemistry. The bq2090 self-discharge estimation rate is externally programmed in E²PROM

and can be programmed from 0 to 25% per day at 20°C. This rate doubles every 10°C from 0°C to 70°C.

Count Compensations

The bq2090 determines fast discharge when the discharge rate exceeds the programmed fast discharge rate. Charge activity is compensated for temperature and rate before updating the RM and/or DCR. Discharge rate is compensated for temperature before updating the RM register. Self-discharge estimation is compensated for temperature before updating RM or DCR.

Charge Compensation

Charge efficiency is compensated for rate, temperature, and battery chemistry. For Li-ion chemistry cells, the charge efficiency is unity for all cases. However, the charge efficiency for nickel chemistry cells is adjusted using the following equation:

$$Q_{EFF} = Q_{EB} + 0.125 * \frac{\text{AverageCurrent}()}{\text{FullCapacity}()}$$

where $Q_{EB} = 0.80$ if $T < 30^\circ\text{C}$

$$Q_{EB} = 0.75 \text{ if } 30^\circ\text{C} \leq T < 40^\circ\text{C}$$

$$Q_{EB} = 0.60 \text{ if } T \geq 40^\circ\text{C}$$

and $\text{AverageCurrent}() \leq \text{FullCapacity}()$

$Q_{EFF} = Q_{EB} + 0.125$ if $\text{AverageCurrent}() > \text{FullCapacity}()$

Remaining Capacity Compensation

The bq2090 adjusts the RM as a function of temperature. This adjustment accounts for the reduced capacity of the battery at colder temperatures. The following equation is used to adjust RM:

If $T \geq 5^\circ\text{C}$

$$\text{RemainingCapacity}() = \text{NominalAvailableCapacity}$$

If $T < 5^\circ\text{C}$

$$\text{RC}() = \text{NAC}() (1 + \text{TCC} * (T - 5^\circ\text{C}))$$

where $T =$ temperature $^\circ\text{C}$

$$\text{TCC} = 0.016 \text{ for Li-Ion cells}$$

$$\text{TCC} = 0.0004 \text{ for Ni chemistry cells}$$

Digital Magnitude Filter

The bq2090 has a programmable digital filter to eliminate charge and discharge counting below a set threshold. Table 2 shows typical digital filter settings. The proper digital filter setting can be calculated using the following equation.

$$V_{SRD} \text{ (mV)} = -45 / \text{DMF}$$

$$V_{SRQ} \text{ (mV)} = -1.25 * V_{SRD}$$

Table 2. Typical Digital Filter Settings

DMF	DMF Hex.	V _{SRD} (mV)	V _{SRQ} (mV)
75	4B	-0.60	0.75
100	64	-0.45	0.56
150 (default)	96	-0.30	0.38
175	AF	-0.26	0.32
200	C8	-0.23	0.28

Error Summary

Capacity Inaccurate

The FCC is susceptible to error on initialization or if no updates occur. On initialization, the FCC value includes the error between the design capacity and the actual capacity. This error is present until a valid discharge occurs and FCC is updated (see the DCR description). The other cause of FCC error is battery wear-out. As the battery ages, the measured capacity must be adjusted to account for changes in actual battery capacity. Periodic discharges from full to empty will minimize errors in FCC.

Current-Sensing Error

Table 3 illustrates the current-sensing error as a function of V_{SR}. A digital filter eliminates charge and discharge counts to the RM register when V_{SRQ} is between V_{SRQ} and V_{SRD}.

bq2090

Display

The bq2090 can directly display capacity information using low-power LEDs. The bq2090 displays the battery charge state in either absolute or relative mode. In relative mode, the battery charge is represented as a percentage of the FCC. Each LED segment represents 25% of the FCC.

In absolute mode, each segment represents a fixed amount of charge, based on the initial design capacity. In absolute mode, each segment represents 25% of the design capacity. As the battery wears out over time, it is possible for the FCC to be below the initial design capacity. In this case, all of the LEDs may not turn on in absolute mode, representing the reduction in the actual battery capacity.

The displayed capacity is compensated for the present battery temperature. The displayed capacity varies as temperature varies, indicating the available charge at the present conditions.

When $\overline{\text{DISP}}$ is tied to V_{CC} , the SEG_{1-4} outputs are inactive. When $\overline{\text{DISP}}$ is left floating, the display becomes active whenever the bq2090 recognizes a valid charge or if the discharge rate exceeds the programmed fast discharge display threshold. When pulled low, the segment outputs become active immediately for a period of approximately 4 seconds.

The segment outputs are modulated as two banks of three, with segments 1 and 3 alternating with segments 2 and 4. The segment outputs are modulated at approximately 100Hz with each segment bank active for 30% of the period.

SEG_1 blinks at a 4Hz rate whenever V_{SB} has been detected to be below V_{EDV1} ($\text{EDV}_1 = 1$), indicating a low-battery condition. V_{SB} below V_{EDVF} ($\text{EDV}_F = 1$) disables the display output.

Microregulator

The bq2090 can operate directly from three or four nickel chemistry cells. To facilitate the power supply requirements of the bq2090, an REF output is provided to regulate an external low-threshold n-FET. A micro-power source for the bq2090 can be inexpensively built using the FET and an external resistor; see Figure 1.

Communicating With the bq2090

The bq2090 includes a simple two-pin (SCC and SCD) bidirectional serial data interface. A host processor uses the interface to access various bq2090 registers; see Table 4. This allows battery characteristics to be easily monitored. The open-drain SCD and SCC pins on the bq2090 are pulled up by the host system, or may be connected to V_{SS} , if the serial interface is not used.

The interface uses a command-based protocol, where the host processor sends the battery address and an eight-bit command byte to the bq2090. The command directs the bq2090 to either store the next data received to a register specified by the command byte or output the data specified by the command byte.

bq2090 Data Protocols

The host system, acting in the role of a Bus master, uses the read word and write word protocols to communicate integer data with the bq2090 (see Figure 3).

Host-to-bq2090 Message Protocol

The Bus Host communicates with the bq2090 using one of three protocols:

- Read word
- Write word
- Read block

The particular protocol used is a function of the command. The protocols used are shown in Figure 3.

Table 3. bq2090 Current-Sensing Errors

Symbol	Parameter	Typical	Maximum	Units	Notes
Vos	Offset referred to V_{SR}	± 50	± 150	μV	$\overline{\text{DISP}} = V_{CC}$.
INL	Integrated non-linearity error	± 2	± 4	%	Add 0.1% per $^{\circ}\text{C}$ above or below 25°C and 1% per volt above or below 4.25V.
INR	Integrated non-repeatability error	± 1	± 2	%	Measurement repeatability given similar operating conditions.

May 1996

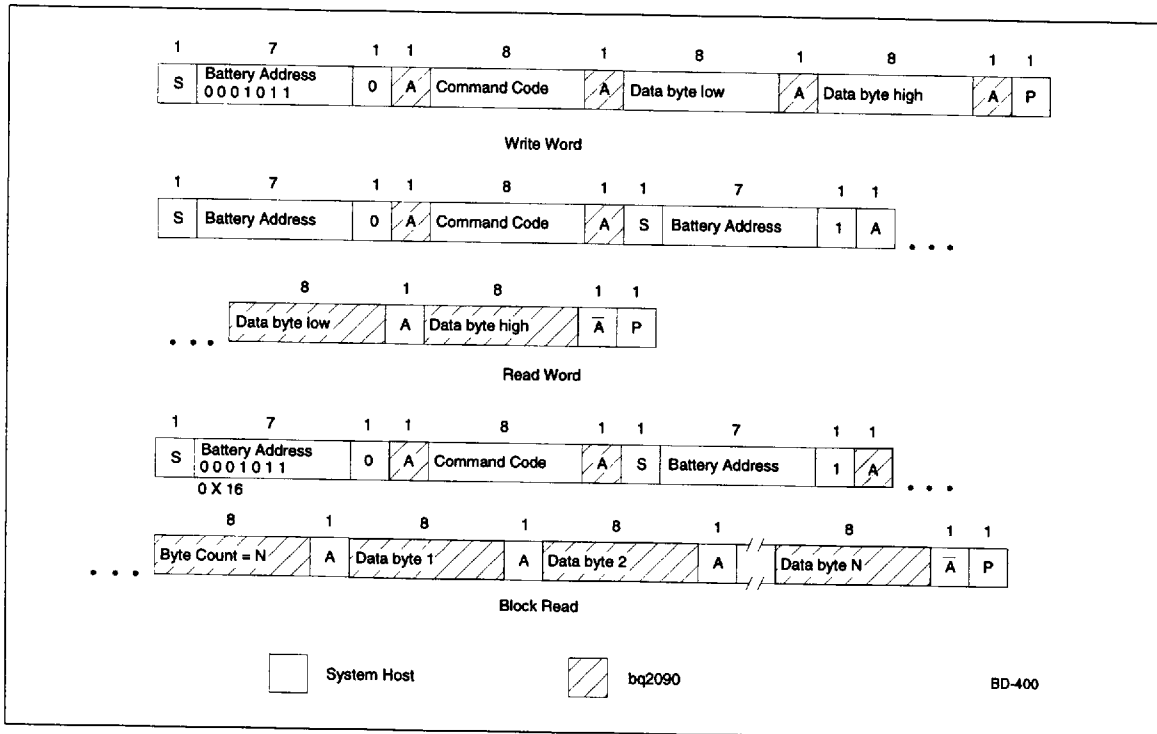

Figure 3. Host Communication Protocols

Host-to-bq2090 Messages (see Table 4)

Temperature() (0x08)

This read-only word returns the cell-pack's internal temperature (0.1°K).

Output: unsigned integer. Returns cell temperature in tenths of degrees Kelvin increments

Units: 0.1°K

Range: 0 to +500.0°K

Granularity: 0.5°K or better

Accuracy: ±3°K after calibration

Voltage() (0x09)

This read-only word returns the cell-pack voltage (mV).

Output: unsigned integer. Returns battery terminal voltage in mV

Units: mV

Range: 0 to 65,535 mV

Granularity: 0.2% of design voltage

Accuracy: ±1% of design voltage after calibration

Current() (0x0a)

This read-only word returns the current through the battery's terminals (mA).

Output: signed integer. Returns the charge/discharge rate in mA, where positive is for charge and negative is for discharge

Units: mA

Range: 0 to 32,767 mA for charge or 0 to -32,768 mA for discharge

Granularity: 0.2% of the DesignCapacity() or better

Accuracy: ±1% of the Design Capacity after calibration

May 1996

bq2090

Table 4. bq2090 Register Functions

Function	Code	Access	Units	Defaults ¹
Temperature	0x08	read	0.1°K	-
Voltage	0x09	read	mV	-
Current	0x0a	read	mA	0000h
AverageCurrent	0x0b	read	mA	0000h
MaxError	0x0c	read	percent	2
RelativeStateOfCharge	0x0d	read	percent	0000h
AbsoluteStateOfCharge	0x0e	read	percent	0000h
RemainingCapacity	0x0f	read	mAh	0000h
FullChargeCapacity	0x10	read	mAh	E ²
RunTimeToEmpty	0x11	read	minutes	-
AverageTimeToEmpty	0x12	read	minutes	-
AverageTimeToFull	0x13	read	minutes	-
Error Codes	0x16	read	number	0000h
CycleCount	0x17	read	count	0000h
DesignCapacity	0x18	read	mAh	E ²
DesignVoltage	0x19	read	mV	E ²
ManufactureDate	0x1b	read	unsigned int	E ²
SerialNumber	0x1c	read	number	E ²
Reserved	0x1d - 0x1f	-	-	-
ManufacturerName	0x20	read	string	E ²
DeviceName	0x21	read	string	E ²
DeviceChemistry	0x22	read	string	E ²
ManufacturerData	0x23	read	string	E ²
FLAGS1 and FLAGS2	0x2c	read	unsigned int.	E ²

Notes: 1. Defaults after reset or power-up.

AverageCurrent() (0x0b)

This read-only word returns a rolling average of the current through the battery's terminals. The AverageCurrent() function returns meaningful values after the battery's first minute of operation.

Output: signed integer. Returns the charge/discharge rate in mA, where positive is for charge and negative is for discharge

Units: mA

Range: 0 to 32,767 mA for charge or 0 to -32,768 mA for discharge

Granularity: 0.2% of the DesignCapacity() or better

Accuracy: $\pm 1\%$ of the Design Capacity after calibration

RelativeStateOfCharge() (0x0d)

This read-only word returns the predicted remaining battery capacity expressed as a percentage of FullChargeCapacity(%). **RelativeStateOfCharge() is only valid for battery capacities less than 5,000mAh.**

Output: unsigned integer. Returns the percent of remaining capacity

Units: %

Range: 0 to 100%

Granularity: 1% or better

AbsoluteStateOfCharge() (0x0e)

This read-only word returns the predicted remaining battery capacity expressed as a percentage of DesignCapacity(%). Note that AbsoluteStateOfCharge can return values greater than 100%. **AbsoluteStateOfCharge is only valid for battery capacities less than 5,000mAh.**

Output: unsigned integer. Returns the percent of remaining capacity

Units: %

Range: 0 to 65,535 %

Granularity: 1% or better

Accuracy: $\pm \text{MaxError}()$

RemainingCapacity() (0x0f)

This read-only word returns the predicted remaining battery capacity. The RemainingCapacity() value is expressed in mAh.

Output: unsigned integer. Returns the estimated remaining capacity in mAh

Units: mAh

Range: 0 to 65,535 mAh

Granularity: 0.2% of DesignCapacity() or better

FullChargeCapacity() (0x10)

This read-only word returns the predicted pack capacity when it is fully charged. FullChargeCapacity() defaults to the value programmed in the external E²PROM until a new pack capacity is learned.

Output: unsigned integer. Returns the estimated full charge capacity in mAh

Units: mAh

Range: 0 to 65,535 mAh

Granularity: 0.2% of design capacity or better

RunTimeToEmpty() (0x11)

This read-only word returns the predicted remaining battery life at the present rate of discharge (minutes). The RunTimeToEmpty() value is calculated based on Current().

Output: unsigned integer. Returns the minutes of operation left

Units: minutes

Range: 0 to 65,534 minutes

Granularity: 2 minutes or better

Invalid data indication: 65,535 indicates battery is being charged

AverageTimeToEmpty() (0x12)

This read-only word returns the predicted remaining battery life at the present average discharge rate (minutes). The AverageTimeToEmpty is calculated based on AverageCurrent().

Output: unsigned integer. Returns the minutes of operation left

Units: minutes

Range: 0 to 65,534 minutes

Granularity: 2 minutes or better

Invalid data indication: 65,535 indicates battery is being charged

bq2090

AverageTimeToFull() (0x13)

This read-only word returns the predicted time until the Smart Battery reaches full charge at the present average charge rate (minutes). The AverageTimeToFull() is calculated based on AverageCurrent().

Output: unsigned integer. Returns the remaining time in minutes

Units: minutes

Range: 0 to 65,534 minutes

Granularity: 2 minutes or better

Invalid data indication: 65,535 indicates battery is not being charged

Battery Status() (0x16)

This read-only word returns the battery status word.

Output: unsigned integer. Returns the status register with alarm conditions bitmapped as shown in Table 5.

Some of the Battery Status() flags (Remaining_Capacity_Alarm and Remaining_Time_Alarm) are calculated based on current. See Table 8 for definitions.

Table 5. Status Register

Alarm Bits	
0x8000	Not Meaningful
0x4000	Not Meaningful
0x2000	Not Meaningful
0x1000	Over_Temp_Alarm
0x0800	Terminate_Discharge_Alarm
0x0400	Reserved
0x0200	Remaining_Capacity_Alarm
0x0100	Remaining_Time_Alarm
Status Bits	
0x0080	Initialized
0x0040	Discharging
0x0020	Not Meaningful
0x0010	Fully Discharged
Error Code	
0x0000-0x000f	Reserved for error codes

CycleCount() (0x17)

This read-only word returns the number of charge/discharge cycles the battery has experienced. A charge/discharge cycle starts from a base value equivalent to the battery's state-of-charge, upon completion of a charge cycle. The bq2090 increments the cycle counter during the current charge cycle, if the battery has been discharged to below 85% of the state-of-charge at the end of the last charge cycle. A discharge > 0.5% is needed, preventing false reporting of small charge/discharge cycles.

Output: unsigned integer. Returns the count of charge/discharge cycles the battery has experienced

Units: cycles

Range: 0 to 65,535 cycles; 65,535 indicates battery has experienced 65,535 or more cycles

Granularity: 1 cycle

DesignCapacity() (0x18)

This read-only word returns the theoretical capacity of a new pack. The DesignCapacity() value is expressed in mAh at the nominal discharge rate.

Output: unsigned integer. Returns the battery capacity in mAh

Units: mAh

Range: 0 to 65,535 mAh

DesignVoltage() (0x19)

This read-only word returns the theoretical voltage of a new pack (mV).

Output: unsigned integer. Returns the battery's normal terminal voltage in mV

Units: mV

Range: 0 to 65,535 mV

ManufactureDate() (0x1b)

This read-only word returns the date the cell was manufactured in a packed integer word. The date is packed as follows: (year - 1980), month, day.

Field	Bits Used	Format	Allowable Value
Day	0-4	5-bit binary value	1-31 (corresponds to date)
Month	5-8	4-bit binary value	1-12 (corresponds to month number)
Year	9-15	7-bit binary value	0 * 127 (corresponds to year biased by 1980)

SerialNumber() (0x1c)

This read-only word returns a serial number. This number, when combined with the ManufacturerName(), the DeviceName(), and the ManufactureDate(), uniquely identifies the battery.

Output: unsigned integer

ManufacturerName() (0x20)

This read-only string returns a character string where the first byte is the number of characters available. The maximum number of characters is 15. The character string contains the battery manufacturer's name. For example, "Benchmark" identifies the battery pack manufacturer as Benchmark.

Output: string or ASCII character string

DeviceName() (0x21)

This read-only string returns a character string where the first byte is the number of characters available. The maximum number of characters is 15. The 15-byte character string contains the battery's name. For example, a DeviceName() of "bq2090" indicates that the battery is a model bq2090.

Output: string or ASCII character string

DeviceChemistry() (0x22)

This read-only string returns a character string where the first byte is the number of characters available. The maximum number of characters is 15. The 15-byte character string contains the battery's chemistry. For example, if the DeviceChemistry() function returns "NiMH," the battery pack contains nickel-metal hydride cells.

Output: string or ASCII character string

FLAGS1&2() (0x2c)

This read-only register returns an unsigned integer representing the internal status registers of the bq2090. The MSB represents FLAGS2, and the LSB represents FLAGS1. See Table 6 for the bit description for FLAGS1&2.

FLAGS2

The *Display Mode* flag (DMODE), Bit 7, determines whether the bq2090 displays Relative or Absolute capacity.

The DMODE values are:

FLAGS2 Bits							
7	6	5	4	3	2	1	0
DMODE	-	-	-	-	-	-	-

Where DMODE is:

- 0 Selects Absolute display
- 1 Selects Relative display

The *Fast Discharge* flag (FDQ), Bit 6, is set when the discharge rate exceeds the programmed level and is cleared when the rate drops below this level.

The FDQ values are:

FLAGS2 Bits							
7	6	5	4	3	2	1	0
-	FDQ	-	-	-	-	-	-

Table 6. Bit Description for FLAGS1 and FLAGS2

	(MSB) 7	6	5	4	3	2	1	0 (LSB)
FLAGS2	DMODE	FDQ	CHM	-	-	-	LTF	-
FLAGS1	-	-	VQ	WRINH	VDQ	SEDV	EDV1	EDVF

- = Reserved

bq2090

Where FDQ is:

- 0 AverageCurrent < Discharge display threshold
- 1 AverageCurrent > Discharge display threshold

The *Chemistry* flag (CHM), Bit 5, selects Li-Ion or Nickel compensation factors.

The CHM values are:

FLAGS2 Bits							
7	6	5	4	3	2	1	0
-	-	CHM	-	-	-	-	-

Where CHM is:

- 0 Selects Nickel
- 1 Selects Li-Ion

Bit 4 is reserved and should be initialized to zero for proper bq2090 operation.

Bit 3 is reserved.

Bit 2 is reserved.

The *Low-Temperature Fault* flag (LTF), Bit 1, is set when temperature < 0°C and cleared when temperature > 5°C.

The LTF values are:

Where LTF is:

FLAGS2 Bits							
7	6	5	4	3	2	1	0
-	-	-	-	-	-	LTF	-

- 0 Temperature > 5°C
- 1 Temperature < 0°C

Bit 0 is reserved.

FLAGS1

Bit 7 is reserved.

Bit 6 is reserved.

The *Valid Charge* flag (VQ), Bit 5, is set when $V_{SRO} \geq V_{SRQ}$ and 10mAh of charge has accumulated. This bit is cleared during a discharge and when $V_{SRO} \leq V_{SRQ}$.

The VQ values are:

FLAGS1 Bits							
7	6	5	4	3	2	1	0
-	-	VQ	-	-	-	-	-

Where VQ is:

- 0 $V_{SRO} \leq V_{SRQ}$
- 1 $V_{SRO} \geq V_{SRQ}$ and 10mAh of charge has accumulated

The *Write Inhibit* flag (WRINH), Bit 4, allows or inhibits writes to all registers.

The WRINH values are:

FLAGS1 Bits							
7	6	5	4	3	2	1	0
-	-	-	WRINH	-	-	-	-

Where WRINH is:

- 0 Allows writes to all registers
- 1 Inhibits all writes and secures the bq2090 from invalid/undesired writes.

WRINH may be cleared by writing Manufacturer Access()=0xXX37 and forcing the SB pin to ground.

The *Valid Discharge* flag (VDQ), Bit 3, is set when a valid discharge is occurring (discharge cycle valid for learning new full charge capacity) and cleared if a partial charge is detected, EDV1 is asserted when $T < 0^\circ\text{C}$, or self-discharge accounts for more than 256mAh of the discharge.

The VDQ values are:

FLAGS1 Bits							
7	6	5	4	3	2	1	0
-	-	-	-	VDQ	-	-	-

Where VDQ is:

- 0 Self-discharge is greater than 256mAh, EDV1 = 1 when $T < 0^\circ\text{C}$ or $VQ = 1$
- 1 On first discharge after $RM = FCC$

The *Stop EDV* flag (SEDV), Bit 2, is set when the discharge current > 3A and cleared when the discharge current falls below 1.5A.

The SEDV values are:

FLAGS1 Bits							
7	6	5	4	3	2	1	0
-	-	-	-	-	SEDV	-	-

Where SEDV is:

- 0 Current < 1.5A
- 1 Current > 3A

The *First End-of-Discharge Voltage* flag (EDV1), Bit 1, is set when Voltage() < EDV1 = 1 if SEDV = 0 and cleared when VQ = 1 and Voltage() > EDV1.

The EDV1 values are:

FLAGS1 Bits							
7	6	5	4	3	2	1	0
-	-	-	-	-	-	EDV1	-

Where EDV1 is:

- 0 VQ = 1 and Voltage () > EDV1
- 1 Voltage() < EDV1 and SEDV = 0

The *Final End-of-Discharge Voltage* flag (EDVF), Bit 0, is set when Voltage() < EDVF = 1 if SEDV = 0 and cleared when VQ = 1 and Voltage() > EDVF.

The EDVF values are:

FLAGS1 Bits							
7	6	5	4	3	2	1	0
-	-	-	-	-	-	-	EDVF

Where EDVF is:

- 0 VQ = 1 and Voltage > EDVF
- 1 Voltage < EDVF and SEDV = 0

ManufacturerData() (0x23)

This read-only string allows access to an up to 15-byte manufacturer data string.

Output: block data—data whose meaning is assigned by the Smart Battery's manufacturer

Software Reset

The bq2090 can be reset over the serial port by confirming that the WRINH bit is set to zero in FLAGS1, writing MaxError() (0x0c) to any value other than 2, and writing the reset register (0x44) to 8000, causing the bq2090 to reinitialize and read the default values from the external E²PROM. See the WRINH bit description if WRINH is set to 1.

Error Codes and Status Bits

Error codes and status bits are listed in Table 7 and Table 8, respectively.

bq2090 Critical Messages

Whenever the bq2090 detects a critical condition, it becomes a bus master and sends Alarm Warning() messages to the Bus Host, as appropriate, notifying it of the critical condition(s). The message sent by the Alarm Warning() function is similar to the message returned by the BatteryStatus() function. The bq2090 continues broadcasting the AlarmWarning() messages at 8-second intervals until the critical condition(s) has been corrected.

AlarmWarning() (0x16)

The bq2090, acting as a bus master device to the Bus Host, sends this message to notify it that one or more alarm conditions exist. Alarm Warning() is repeated at 8-second intervals until the condition(s) causing the alarm has been corrected.

bq2090

Table 7. Error Codes (BatteryStatus() (0x16))

Error	Code	Access	Description
OK	0x0000	read/write	bq2090 processed the function code without detecting any errors
Busy	0x0001	read/write	bq2090 is unable to process the function code at this time
NotReady	0x0002	read/write	bq2090 cannot read or write the data at this time—try again later
UnsupportedCommand	0x0003	read/write	bq2090 does not support the requested function code
AccessDenied	0x0004	write	bq2090 detected an attempt to write to a read-only function code
Overflow/Underflow	0x0005	read/write	bq2090 detected a data overflow or underflow
BadSize	0x0006	write	bq2090 detected an attempt to write to a function code with an incorrect size data block
UnknownError	0x0007	read/write	bq2090 detected an unidentifiable error

Note: Reading the bq2090 after an error clears the error code.

Table 8. Status Bits

Alarm Bits		
Bit Name	Set When:	Reset When:
OVER_TEMP_ALARM	bq2090 detects that its internal temperature is greater than 60°C	Internal temperature falls back into the acceptable range
TERMINATE_DISCHARGE_ALARM	bq2090 determines that it has supplied all the charge that it can without being damaged (that is, continued use will result in permanent capacity loss to the battery)	Battery reaches a state of charge sufficient for it to once again safely supply power
REMAINING_CAPACITY_ALARM	bq2090 detects that the RemainingCapacity() is less than that set by the RemainingCapacity() function	Either the value set by the RemainingCapacityAlarm() function is lower than the RemainingCapacity() or the RemainingCapacity() is increased by charging
REMAINING_TIME_ALARM	bq2090 detects that the estimated remaining time at the present discharge rate is less than that set by the RemainingTimeAlarm() function	Either the value set by the RemainingTimeAlarm() function is lower than the AverageTimeToEmpty() or the AverageTimeToEmpty() is increased by charging
Status Bits		
Bit Name	Set When:	Reset When:
INITIALIZED	bq2090 is set when the bq2090 has reached a full or empty state	Battery detects that power-on or user-initiated reset has occurred
DISCHARGING	bq2090 determines that it is not being charged	Battery detects that it is being charged
FULLY_DISCHARGED	bq2090 determines that it has supplied all the charge that it can without being damaged (that is, continued use will result in permanent capacity loss to the battery)	RelativeStateOfCharge() is greater than or equal to 20%

bq2090

Programming the bq2090

The bq2090 requires the proper programming of an external E²PROM for proper device operation. Each module can be calibrated for the greatest accuracy, or general "default" values can be used. A programming kit (interface board, software, and cable) for an IBM-compatible PC is available from Benchmarq. Please contact Benchmarq for further detail

The bq2090 uses a 24C01 or equivalent serial E²PROM for storing the various initial values, calibration data, and string information. Table 1 outlines the parameters and addresses for this information. Tables 9 and 10 detail the various register contents and show an example program value for an 1800mAh NiMH battery pack, using a 50mΩ sense resistor.

Table 9. Example Register Contents

Description	E ² PROM Address		E ² PROM Hex Contents		Example Values	Notes
	Low Byte	High Byte	Low Byte	High Byte		
Design Capacity	0x00	0x01	08	07	1800mAh	This sets the initial full charge battery capacity stored in FCC. FCC is updated with the actual full to empty discharge capacity after a valid discharge from RM = FCC to Voltage() = EDV1.
Initial Battery Voltage	0x02	0x03	30	2a	10800mV	This register is used to adjust the battery voltage. Comparing the values read from the bq2090 to two known input voltages allows the bq2090 to calibrate the battery voltage to within 1%. This action adjusts for errors in the resistor-dividers used for the SB input and bq2090 offset errors.
Reserved	0x04	0x05	ff	ff		This register function is reserved.
Reserved	0x06	0x07	ff	ff		This register function is reserved.
Remaining Capacity Alarm	0x08	0x09	b4	00	180mAh	This value represents the low capacity alarm value.
FLAGS1	0x0a		10			This enables writes to all registers and should be set to 10h prior to pack shipment to inhibit undesirable writes to the bq2090.
FLAGS2	0x0b		80		Li-Ion = a0h NiMH = 80h	See FLAGS2 register for the bit description and the proper value for programming FLAGS2. Selects relative display mode and Lithium Ion compensation factors.
Current Measurement Gain ¹	0x0c	0x0d	77	01	18.75/05	The current gain measurement and current integration gain are related and defined for the bq2090 current measurement. 0x0c = 18.75/sense resistor value in ohms.
EDV1	0x0e	0x0f	16	db	9450mV (1.05V/cell)	The value programmed is the two's complement of the threshold voltage in mV.
EDVF	0x10	0x11	d8	dc	9000mV (1.0V/cell)	The value programmed is the two's complement of the threshold voltage in mV.

Note: 1. Can be adjusted to calibrate the battery pack.

Table 9 Continued

Description	E ² PROM Address		E ² PROM Hex Contents		Example Values	Notes
	Low Byte	High Byte	Low Byte	High Byte		
Temperature Offset ¹	0x12	0x13	28	15	541.6	The default value is 540.1K.
Self-Discharge Rate	0x14		f0		.15C	This packed field is the 2's complement of ((RM/4)/(RM/x)) where RM/x is the desired self-discharge rate per day at room temperature.
Digital Filter	0x15		fa		.18mV	This field is used to set the digital magnitude filter as described in Table 2.
Current Integration Gain	0x16	0x17	40	00	3.2/.05	This field represents the following: 3.2/sense resistor in ohms. It is used by the bq2090 to scale the measured voltage values on the SR pin in mA and mAh. This register also compensates for variations in the reported sense resistor value.
Discharge Display Threshold	0x18		fb		$I_{fd} = C/10 = 180\text{mA}$ $45/(180 * .05) = 5$ 2s (5) = fb	This packed field is the 2's complement of the desired voltage on SR which activates the LED display. $fdqthr = 2's(-45/(I_{fd} * R_s))$ where I_{fd} is the desired fast discharge current and R_s is the sense resistor value in ohms. This is only valid when $DISP = Z$.
Battery Voltage Offset ¹	0x19		00		0mV	This value is used to adjust the voltage offset measured at the SB input.
Voltage Gain ¹	0x1a	0x1b	09	05	9.02	Voltage gain is packed as two units. For example, $R5/R2 = 9.09$ would be stored as: whole number stored in 0x1a (=09h) and the decimal component stored in 0x1b as $256 * 0.02 = 05$.
Reserved	0x1c 0x1e	0x1d 0x1f	ff 00	ff 00		This register is reserved.
Design Voltage	0x32	0x33	30	2a	10800mV	This is nominal battery pack voltage.
Specification Information	0x34	0x35	00	00		This is the default value for this register.
Manufacturer Date	0x36	0x37	a1	20	May 1, 1996 = 8353	Packed per the ManufactureDate() description, which represents May 1, 1996 in this example.
Serial Number	0x38	0x39	12	27	10002	This contains the pack serial number, if desired.

Note: 1. Can be adjusted to calibrate the battery pack.

bq2090

Table 10. Example Program Values

String Description	Address	0x ?0	0x ?1	0x ?2	0x ?3	0x ?4	0x ?5	0x ?6	0x ?7	0x ?8	0x ?9-?f
Reserved	0x3a- 0x3f	00	00	00	00	00	00	00	00	00	00
Manufacturer's Name	0x40- 0x4f	09	42 B	45 E	4e N	43 C	48 H	4d M	41 A	52 R	51 Q
Device Name	0x50- 0x5f	08	42 B	51 Q	32 2	30 0	39 9	30 0	41 A	33 3	00- 00
Chemistry	0x60- 0x6f	04	4e N	69 I	4d M	48 H	00	00	00	00	00- 00
Manufacturer's Data	0x70- 0x7f	04	44 D	52 R	31 1	35 5	00	00	00	00	00- 00

Absolute Maximum Ratings

Symbol	Parameter	Minimum	Maximum	Unit	Notes
V _{CC}	Relative to V _{SS}	-0.3	+7.0	V	
All other pins	Relative to V _{SS}	-0.3	+7.0	V	
REF	Relative to V _{SS}	-0.3	+8.5	V	Current limited by R1 (see Figure 1)
V _{SR}	Relative to V _{SS}	-0.3	+7.0	V	Minimum 100Ω series resistor should be used to protect SR in case of a shorted battery (see the bq2090 application note for details).
T _{OPR}	Operating temperature	0	+70	°C	Commercial

Note: Permanent device damage may occur if **Absolute Maximum Ratings** are exceeded. Functional operation should be limited to the Recommended DC Operating Conditions detailed in this data sheet. Exposure to conditions beyond the operational limits for extended periods of time may affect device reliability.

DC Voltage Thresholds (T_A = T_{OPR}; V = 3.0 to 5.5V)

Symbol	Parameter	Minimum	Typical	Maximum	Unit	Notes
E _{VSB}	Battery voltage error relative to SB	-50mV	-	50mV	V	See note

Note: The accuracy of the voltage measurement may be improved by adjusting the battery voltage offset and gain, stored in external E²PROM. For proper operation, V_{CC} should be 1.5V greater than V_{SB}.

May 1996

DC Electrical Characteristics (TA = TOPR)

Symbol	Parameter	Minimum	Typical	Maximum	Unit	Notes
VCC	Supply voltage	3.0	4.25	5.5	V	VCC excursion from < 2.0V to ≥ 3.0V initializes the unit.
VREF	Reference at 25°C	5.7	6.0	6.3	V	IREF = 5μA
	Reference at -40°C to +85°C	4.5	-	7.5	V	IREF = 5μA
RREF	Reference input impedance	2.0	5.0	-	MΩ	VREF = 3V
ICC	Normal operation	-	90	135	μA	VCC = 3.0V
		-	120	180	μA	VCC = 4.25V
		-	170	250	μA	VCC = 5.5V
VSB	Battery input	0	-	VCC	V	
R _{SBmax}	SB input impedance	10	-	-	MΩ	0 < VSB < VCC
IDISP	DISP input leakage	-	-	5	μA	VDISP = VSS
ILVOUT	VOUT output leakage	-0.2	-	0.2	μA	E ² PROM off
VSR	Sense resistor input	-0.3	-	2.0	V	VSR < VSS = discharge; VSR > VSS = charge
RSR	SR input impedance	10	-	-	MΩ	-200mV < VSR < VCC
VIH	Logic input high	1.4	-	5.5	V	SCL, SDA, SCC, SCD
VIL	Logic input low	-0.5	-	0.6V	V	SCL, SDA, SCC, SCD
VOL	Data, clock output low	-	-	0.4	V	IOL=350μA, SDA, SCD
IOL	Sink current	100	-	350	μA	VOL≤0.4V, SDA, SCD
VOLSL	SEG _x output low, low VCC	-	0.1	-	V	VCC = 3V, IOLS ≤ 1.75mA SEG ₁ -SEG ₄
VOLSH	SEG _x output low, high VCC	-	0.4	-	V	VCC = 5.5V, IOLS ≤ 11.0mA SEG ₁ -SEG ₄
VOHVL	VOUT output, low VCC	VCC - 0.3	-	-	V	VCC = 3V, IVOUT = -5.25mA
VOHVH	VOUT output, high VCC	VCC - 0.6	-	-	V	VCC = 5.5V, IVOUT = -33.0mA
IVOUT	VOUT source current	-33	-	-	mA	At VOHVH = VCC - 0.6V
IOLS	SEG _x sink current	-	-	11.0	mA	At VOLSH = 0.4V

Note: All voltages relative to VSS.

bq2090

AC Specifications

Symbol	Parameter	Min	Max	Units	Notes
F_{SMB}	SMBus operating frequency	10	100	KHz	
T_{BUF}	Bus free time between stop and start condition	4.7		μs	
$T_{HD:STA}$	Hold time after (repeated) start condition	4.0		μs	
$T_{SU:STA}$	Repeated start condition setup time	250		ns	SCD
		4.7		μs	External Memory
$T_{SU:STO}$	Stop condition setup time	4.0		μs	
$T_{HD:DAT}$	Data hold time	0		ns	
$T_{SU:DAT}$	Data setup time	250	40	ns	
T_{EXT1}	Data buffering time addresses 0x00-0x18 per character		40	ms	
T_{EXT2}	String buffering time addresses 0x19-0x23 per character		15	ms	40 ms for first character
T_{PD}	Data output delay time	300	3500	ns	External memory only. See Note.
T_{LOW}	Clock low period	4.7		μs	
T_{HIGH}	Clock high period	4.0		μs	
T_F	Clock/Data fall time		300	ns	
T_R	Clock/data rise time		1000	ns	

Note: The external memory must provide this internal minimum delay time to bridge the undefined region (minimum 300 ns) of the falling edge of SCL to avoid unintended generation of START or STOP conditions.

Bus Timing Data

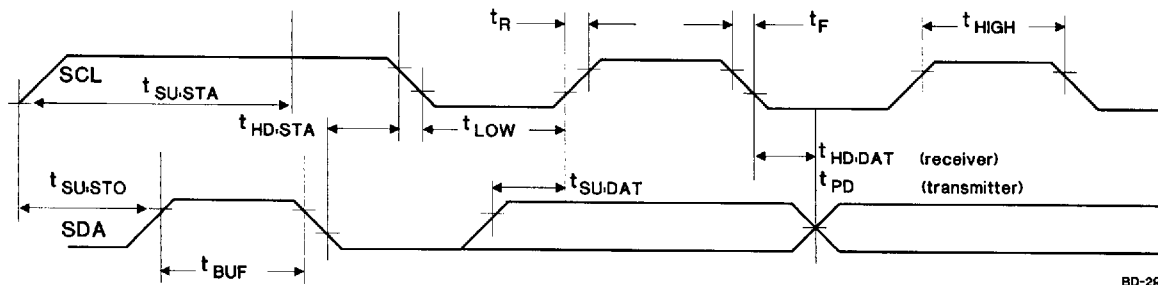

BD-292

May 1996

16-Pin SOIC Narrow (SN)

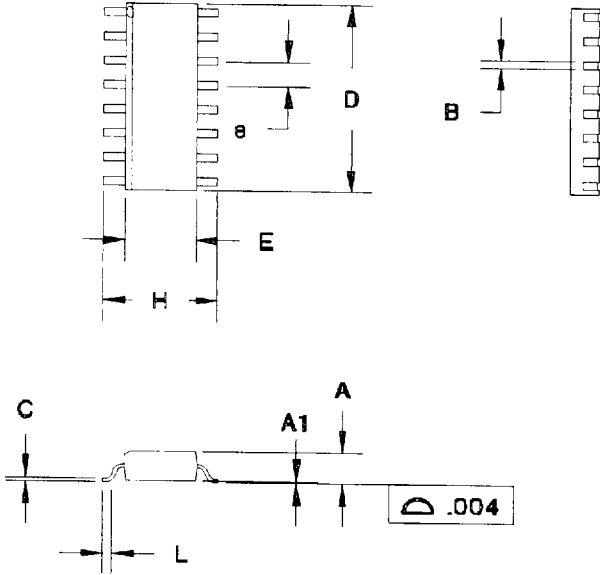

16-Pin SN (0.150" SOIC)

Dimension	Inches		Millimeters	
	Min.	Max.	Min.	Max.
A	0.060	0.070	1.52	1.78
A1	0.004	0.010	0.10	0.25
B	0.013	0.020	0.33	0.51
C	0.007	0.010	0.18	0.25
D	0.385	0.400	9.78	10.16
E	0.150	0.160	3.81	4.06
e	0.045	0.055	1.14	1.40
H	0.225	0.245	5.72	6.22
L	0.015	0.035	0.38	0.89

Ordering Information

bq2090

Temperature Range:
blank = Commercial (-20 to +70°C)

Package Option:
SN = 16-pin narrow SOIC

Device:
bq2090 Gas Gauge IC With SMBus-Like Interface