

PRODUCT DATA DRAWING

REVISION HISTORY			
REV	DESCRIPTION	DATE	APPROVED
B	DCN 49585	01/20	DAL
C	DCN 50234	10/20	BNK

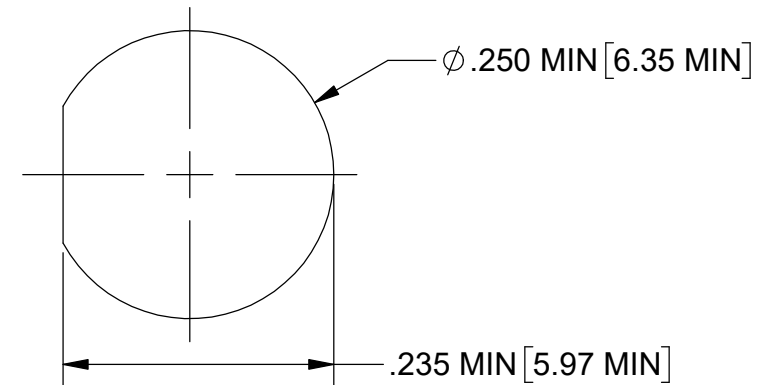
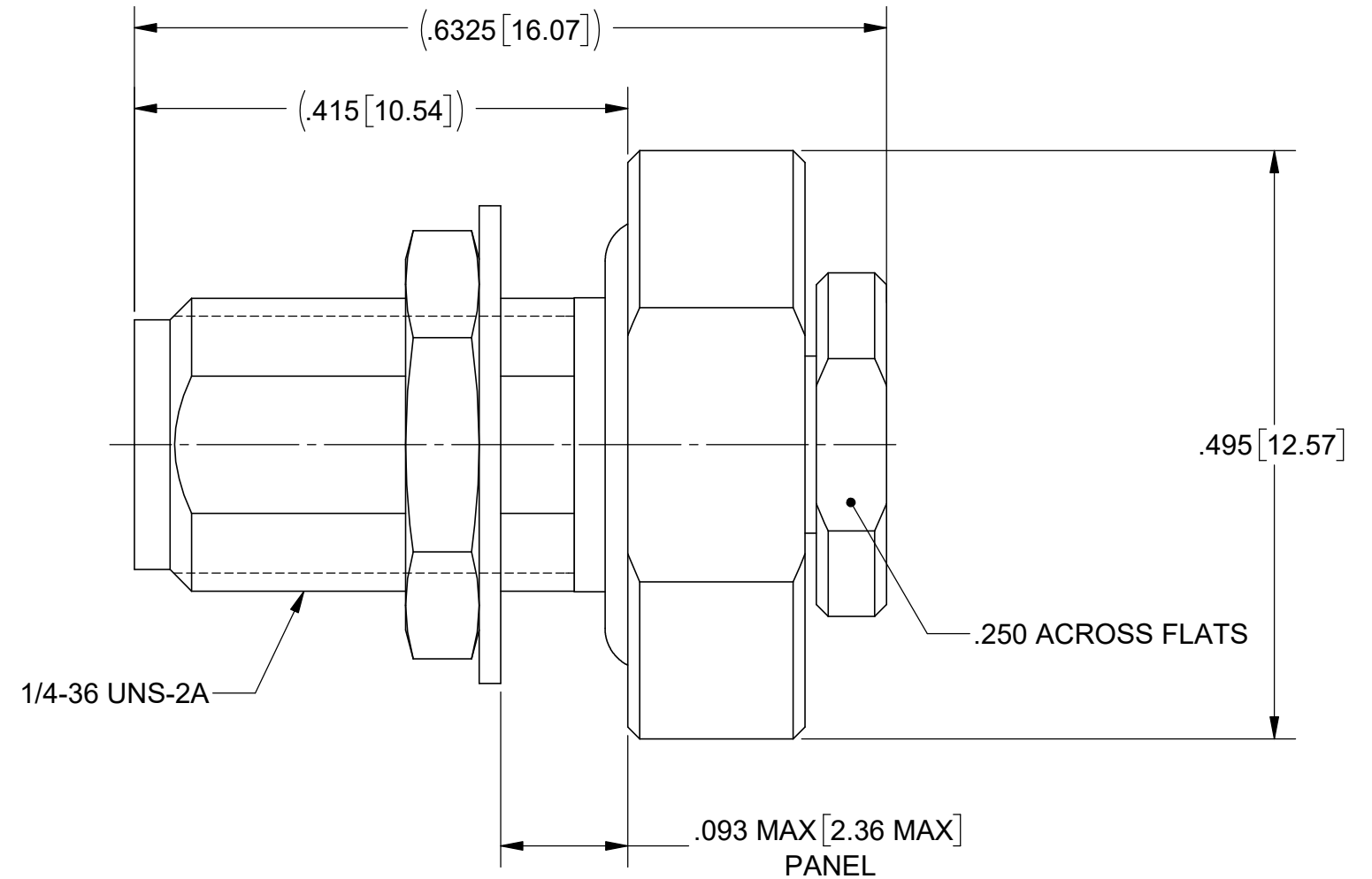
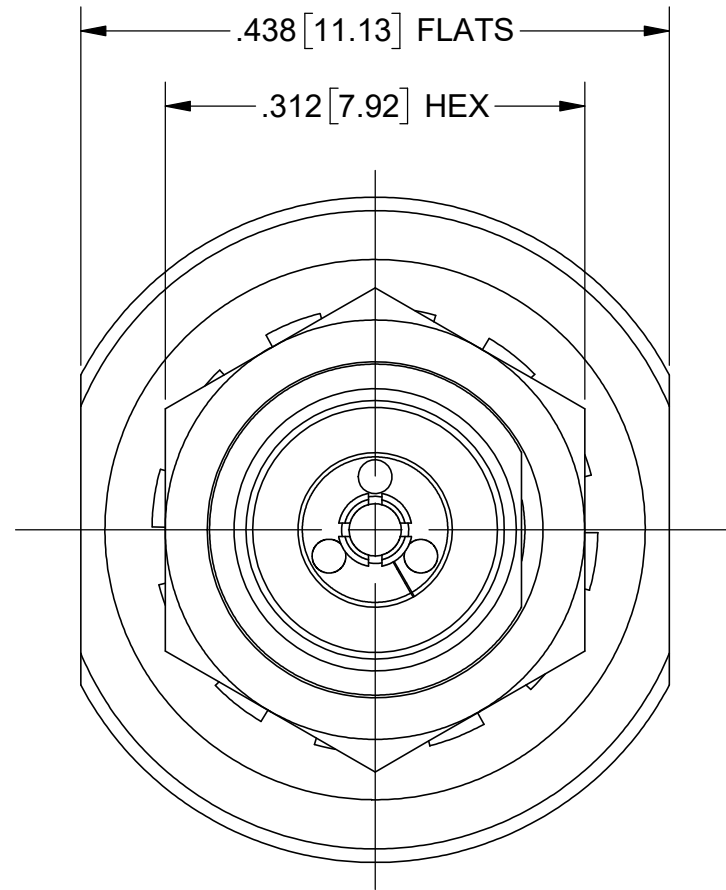
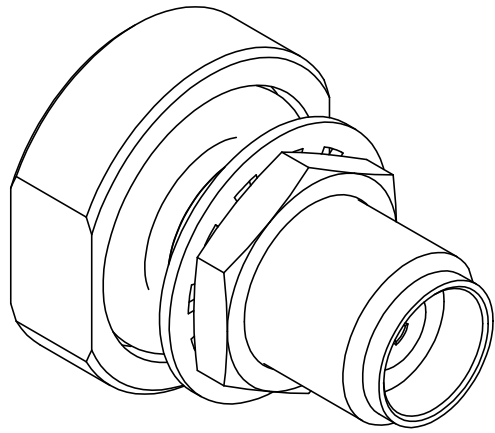

MATERIAL:

BODY, SLEEVE, HEX NUT & CLAMP NUT: STAINLESS STEEL PER AMS 5640, ALLOY No. UNS S30300, TYPE 1, OR ASTM A582, TYPE 303, CONDITION A.

LOCK WASHER: 300 SERIES STAINLESS STEEL

CONTACT & FERRULE: BERYLLIUM COPPER PER ASTM B196, ALLOY No. UNS C17300, TD04

BEAD: POLYETHERIMIDE(ULTEM 1000) PER ASTM D5205

O-RING: SILICONE RUBBER PER A-A-59588, CLASS 2B, GRADE 50/60

FINISH:

BODY, SLEEVE, HEX NUT, LOCK WASHER & CLAMP NUT: PASSIVATED PER AMS 2700.

CONTACT & FERRULE: GOLD PER ASTM B 488, TYPE II, CODE C, CLASS .76, OVER NICKEL PER AMS-QQ-N-290, CLASS 1, .00005" MIN.

PERFORMANCE:

IMPEDANCE: 50 OHMS
 FREQ. RANGE: DC TO 40.0 GHz.
 VSWR: 1.25:1, DC TO 40.0 GHz.

MATERIAL: SEE NOTES	DIMENSIONS ARE IN INCHES TOLERANCES: FRACTIONAL: ±1/64 ANGULAR: X° ±1'0" X"X' ±15'	UNLESS OTHERWISE SPECIFIED 1) ALL DIMENSIONS ARE IN INCHES (MILLIMETERS) 2) ALL DIMENSIONS ARE AFTER PLATING 3) BREAK CORNERS & EDGES .005 R. MAX. 4) CHAM. 1ST & LAST THREADS. 5) SURFACE ROUGHNESS 63-MIL-STD-10. 6) DIA. 'S ON COMMON CENTERS TO BE CONCENTRIC WITHIN .005 T.I.R. 7) REMOVE ALL BURRS	 Amphenol www.svmicrowave.com TITLE: SVK ST. BULKHEAD JACK FOR RG-405 CABLE
FINISH: SEE NOTES	DECIMAL: X ±.030 .XX ±.010 .XXX ±.005	INTERPRET DIMENSIONS AND TOLERANCES PER ASME Y14.5M - 1994	
SURFACE AREA: N/A	THIRD ANGLE PROJECTION	DRAWN: FED 07/27/12	SIZE DWG. NO. SF1521-60025
PROPRIETARY THE INFORMATION CONTAINED IN THIS DRAWING IS THE SOLE PROPERTY OF SV MICROWAVE, INC. ANY REPRODUCTION IN PART OR AS A WHOLE WITHOUT THE WRITTEN PERMISSION OF SV MICROWAVE, INC IS PROHIBITED.		CHECKED: STW 08/22/12	SCALE: 7:1
		APPROVED: STW 08/22/12	SHEET 1 OF 1