

**HANDLE SHANKS**

Glass-fibre reinforced polyamide based (PA) technopolymer, black colour, matte finish.

Supplied assembled. The seat for housing the tube in the shank is shaped so as to prevent its rotation.

**TUBE**

Glass-fibre reinforced polyester, black colour with high resistivity. High resistance to wear, scratches and agents.

**MOUNTING**

Rear fastening with screws M10. Two reference pins (to be fitted during assembly) guarantee a precise positioning.

**MECHANICAL AND DIELECTRIC FEATURES**

Tensile stress: F2 values reported in the table are the result of breaking tests carried out with the appropriate dynamometric equipment under the test conditions shown in the figure with ambient temperature. The following table lists the main dielectric features of the tube.

**ACCESSORIES ON REQUEST**

Intermediate shank for tube (recommended for lengths greater than 700 mm): code 15305 SCM.1043-30.



- 1
- 2
- 3
- 4
- 5
- 6
- 7
- 8
- 9
- 10
- 11
- 12
- 13
- 14
- 15
- 16
- 17
- 18

ELESA Original design

Dielectric features of the tube	
Volume Resistivity	10 <sup>10</sup> + 10 <sup>15</sup> [Ω *cm]
Surface resistivity	10 <sup>10</sup> + 10 <sup>13</sup> [Ω*] (according to IEC93 standard)
Dielectric resistivity	8 [KV/mm]
Comparative tracking index (CTI)	> 600 (V)
Dielectric constant	5

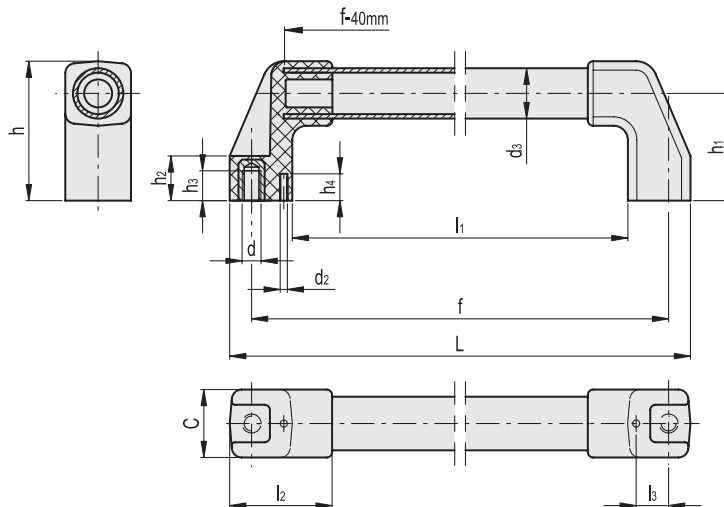
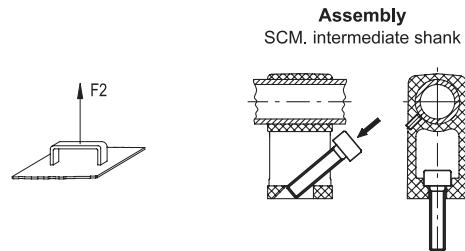

Conversion Table 1 mm = 0.039 inch	
L	
mm	inch
524	20.63
724	28.50

Code	Description	d3	fs1	L	d	h	h1	h2	h3	h4	l1	l2	l3	d2	C	F2 [N]*	F2 [N]#	⚖
37776	M.1043/30-500-HEI	30	500	524	M10	78	60	25	17	15	454	57	18	4	38	3000	4500	495
37786	M.1043/30-700-HEI	30	700	724	M10	78	60	25	17	15	654	57	18	4	38	2000	3500	630

\* Maximum working load # Load at breakage.