

DO NOT SCALE FROM THIS PRINT

DIMENSIONS ARE IN INCHES		UNLESS OTHERWISE NOTED	TOLERANCES ARE:
ONE PLACE DECIMALS ±.1	THREE PLACE DECIMALS ± .005	ANGLES ± 2°	
TWO PLACE DECIMALS ±.01	FOUR PLACE DECIMALS ± .0020		

TITLE:	DWG NO:
ZML ASSEMBLY	ZML-1XX-XX-XX-X
	SHEET 1 OF 1

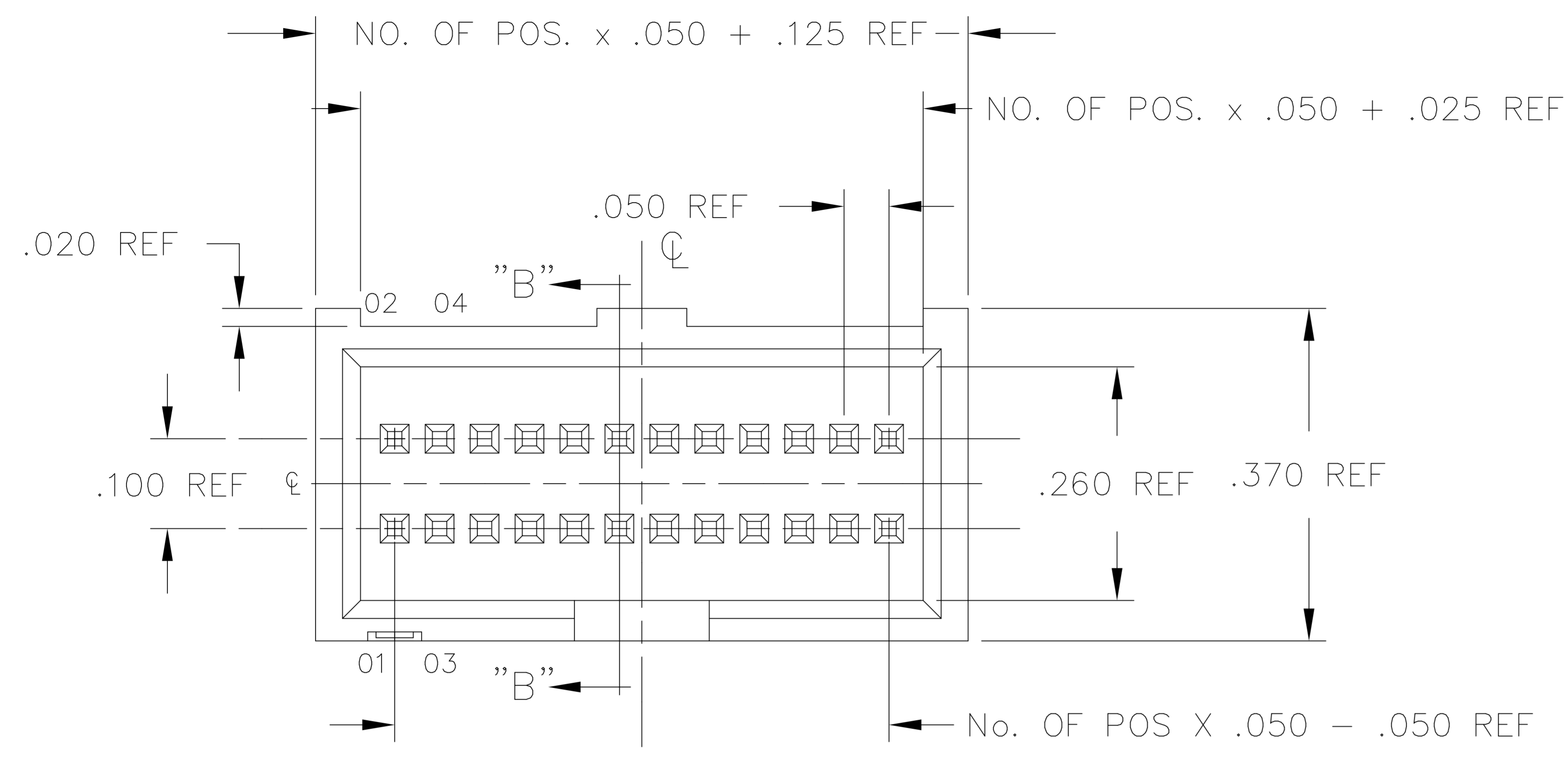

ZML-1XX-XX-XX-X

NO. OF POSITIONS
-05 THRU -50

LEAD STYLE
SEE TABLE 2

ROW SPECIFICATION
-D: DOUBLE
(USE TML-XX-D-LC & HTMS-50-D)

PLATING SPECIFICATION

- G: GOLD- (SEE T-1M6-XX-G-2)
- S: SELECTIVE, MATTE TIN TAIL- (SEE T-1M6-XX-S-2)
- H: HEAVY GOLD- (SEE T-1M6-XX-H-2)
- T: SEE NOTE 2
- TM: MATTE TIN (SEE T-1M6-XX-T-2)
- SM: SELECTIVE GOLD/MATTE TIN TAIL (SEE T-1M6-XX-S-2)
- L: LIGHT SELECTIVE GOLD/MATTE TIN TAIL (SEE T-1M6-XX-L-2)

TABLE 1

1	TML-XX-D-LC
2	HTMS-50-D
3	T-1M6-XX-XX-2

TABLE 2

LEAD STYLE	TERMINAL	"A"
-01	T-1M6-14-XX-2	.505
-02	T-1M6-03-XX-2	.560
-03	T-1M6-05-XX-2	.655
-04	T-1M6-16-XX-2	.775

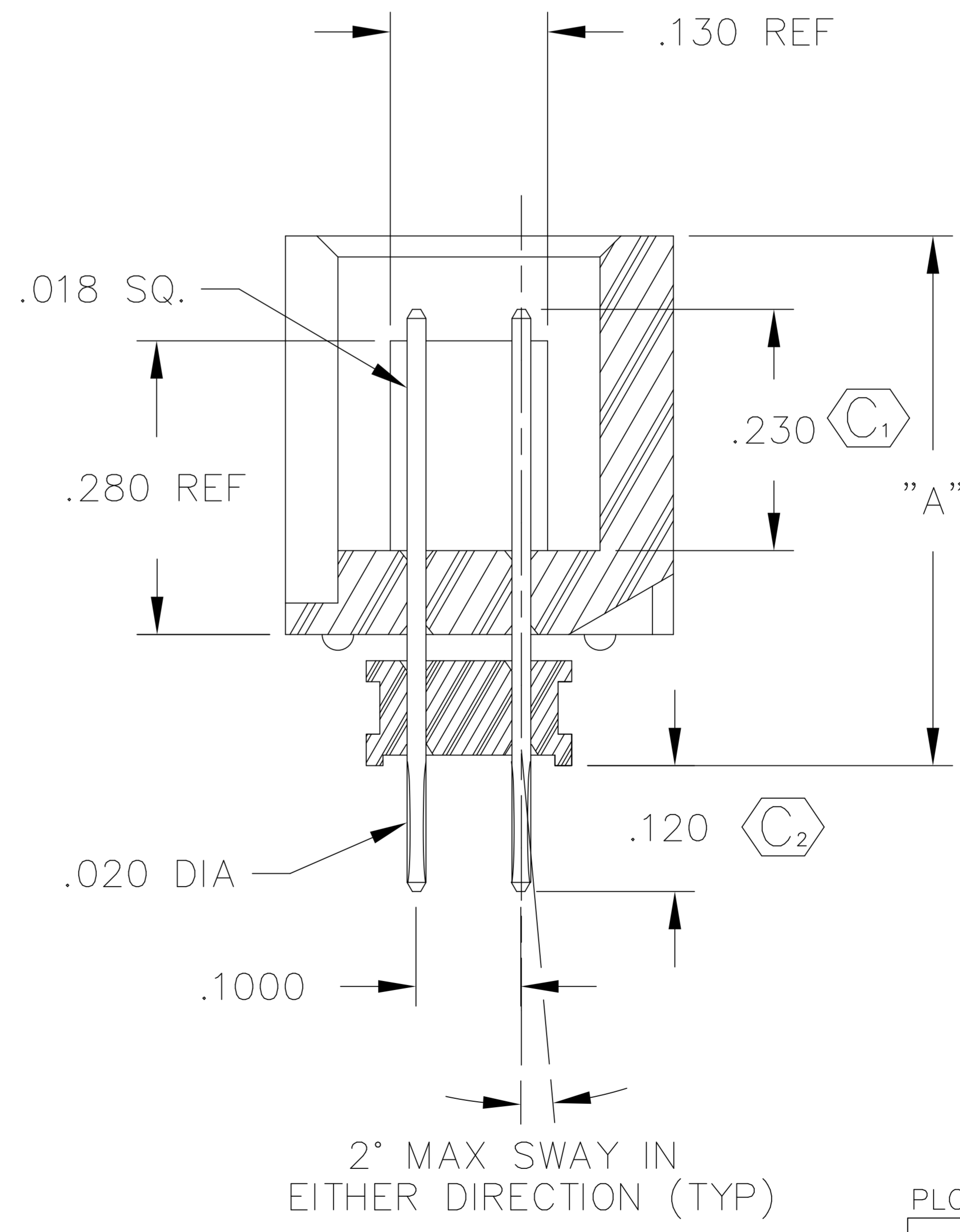
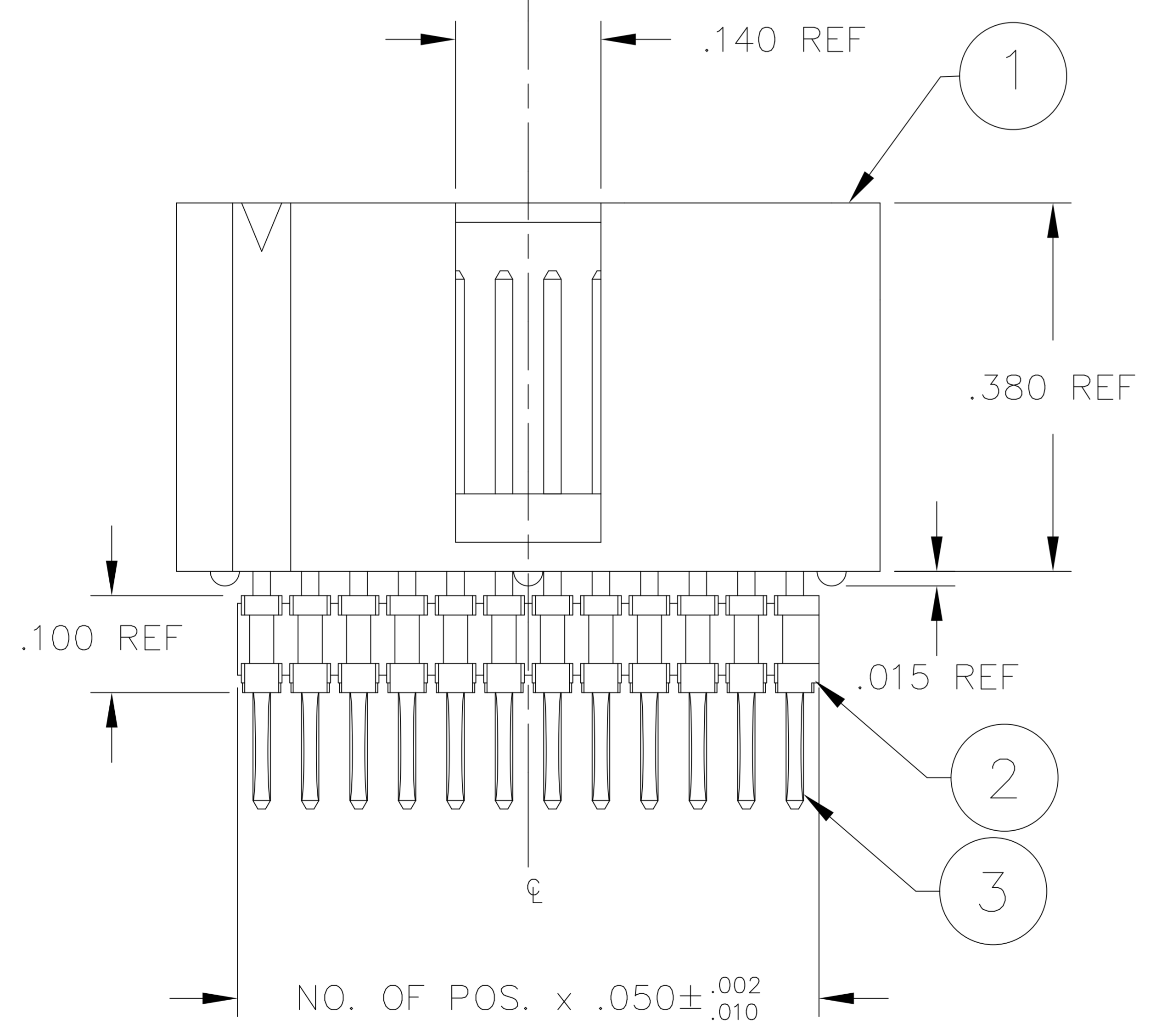

- NOTES:
- 1.) C REPRESENTS A CRITICAL DIMENSION FOR STATISTICAL PROCESS CONTROL USE.
 - 2.) TIN PLATING SUPPORTED FOR EXSISTING CUSTOMERS ONLY.
 - 3.) FOR ADDED MECHANICAL STABILITY, SAMTEC RECOMMENDS MECHANICAL BOARD SPACERS BE USED IN APPLICATIONS WITH GOLD OR SELECTIVE GOLD PLATED CONNECTORS. CONTACT IPG@SAMTEC.COM FOR MORE INFORMATION

PROPRIETARY NOTE

THIS DOCUMENT CONTAINS INFORMATION CONFIDENTIAL AND PROPRIETARY TO SAMTEC INC. AND SHALL NOT BE REPRODUCED OR TRANSFERRED TO OTHER DOCUMENTS OR DISCLOSED TO OTHERS OR USED FOR ANY PURPOSE OTHER THAN THAT FOR WHICH IT WAS OBTAINED WITHOUT THE EXPRESSED WRITTEN CONSENT OF SAMTEC INC.

PLOT SCALE 1=.2

EXISPROD\ASSEMBLY\050
ZML-ASM

520 PARK EAST BLVD. NEW ALBANY, INDIANA 47150
PHONE (812) 944-6733 P.O. BOX 1147
CODE 55322

MADE BY: GREG REIDINGER 4-4-91	ENG. APPROVAL: PAE	ZML-1XX-XX-XX-X
CHECKED BY: ECKERT		SHEET 1 OF 1