

FIG 2
SHIELD OPTION
LSEM-120-01-XX-DH-A-S-X SHOWN
(SAME AS FIG1 DIFFERENT AS SHOWN)

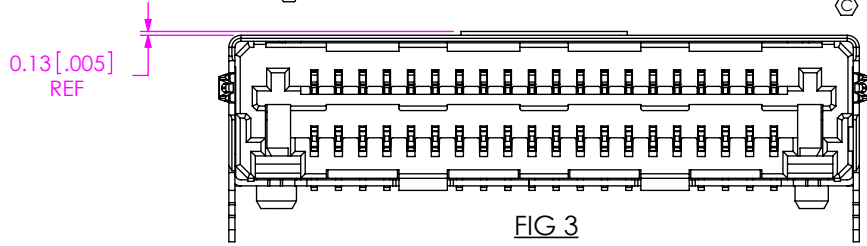
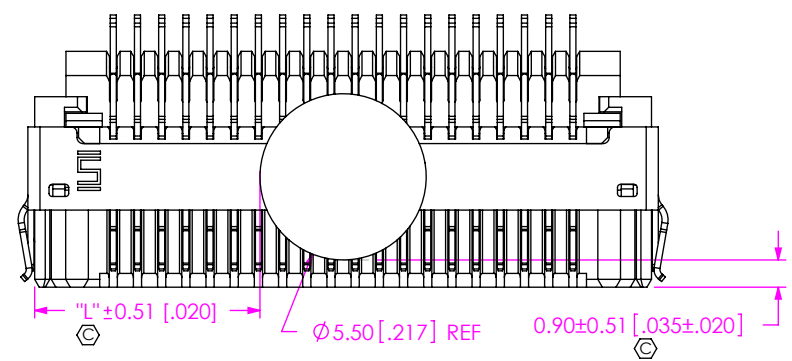

FIG 3
-K KAPTON OPTION
LSEM-120-01-XX-DH-A-S-K SHOWN
(SAME AS FIG1 DIFFERENT AS SHOWN)

TABLE 1

No OF POSITIONS	"F"	"G"	"H"	"J"	"K"	"L"
-20	17.60 [0.693]	20.40 [0.803]	20.85 [0.821]	17.70 [0.697]	21.70 [0.854]	7.45 [0.293]
-30	25.60 [1.008]	28.40 [1.118]	28.85 [1.136]	25.70 [1.012]	29.70 [1.169]	11.45 [0.451]
-40	33.60 [1.323]	36.40 [1.433]	36.85 [1.451]	33.70 [1.327]	37.70 [1.484]	15.45 [0.608]
-50	41.60 [1.638]	44.40 [1.748]	44.85 [1.766]	41.70 [1.642]	45.70 [1.799]	19.45 [0.766]

PROPRIETARY NOTE
THIS DOCUMENT CONTAINS CONFIDENTIAL AND PROPRIETARY INFORMATION AND ALL DESIGN, MANUFACTURING, REPRODUCTION, USE, PATENT RIGHTS AND SALES RIGHTS ARE EXPRESSLY RESERVED BY SAMTEC, INC. THIS DOCUMENT SHALL NOT BE DISCLOSED, IN WHOLE OR PART, TO ANY UNAUTHORIZED PERSON OR ENTITY NOR REPRODUCED, TRANSFERRED OR INCORPORATED IN ANY OTHER PROJECT IN ANY MANNER WITHOUT THE EXPRESS WRITTEN CONSENT OF SAMTEC, INC.
DO NOT SCALE DRAWING
SHEET SCALE: 1:0.2



520 PARK EAST BLVD, NEW ALBANY, IN 47150
PHONE: 812-944-6733 FAX: 812-948-5047
PHONE: 812-944-6733 FAX: 812-948-5047

DESCRIPTION:
0.8mm HERMAPHRODITIC HORIZONTAL FOR LSEM -DH
DWG. NO.
LSEM-1XX-XX-X-DH-A-X-X-XR
BY: CHADP 04/08/2009 SHEET 2 OF 3

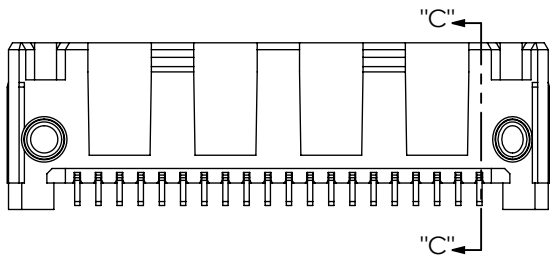
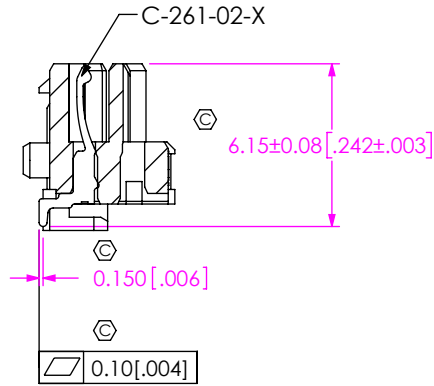
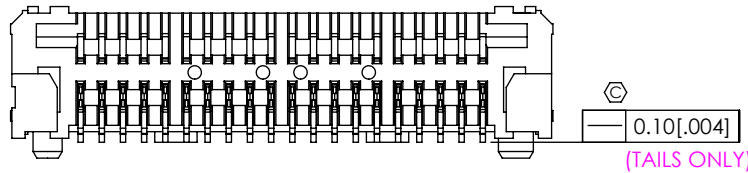

FIG 4
(IN PROCESS 1)



SECTION "C"-"C"
SCALE 3.5 : 1



BACK VIEW

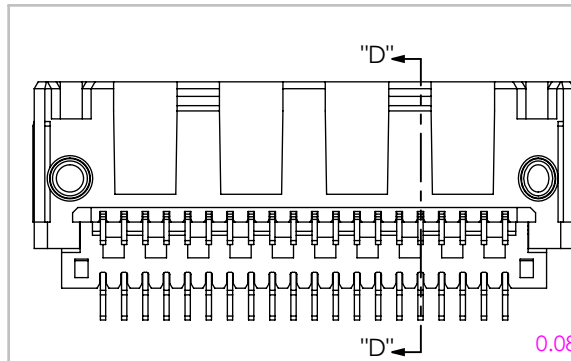
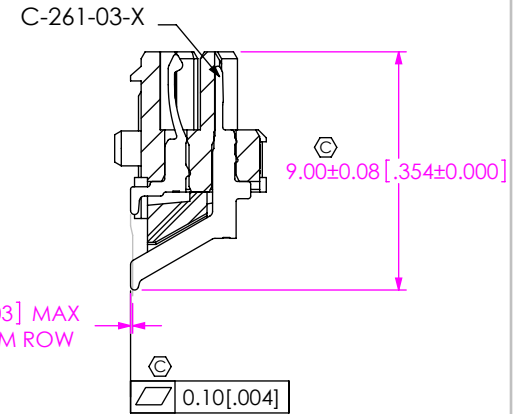
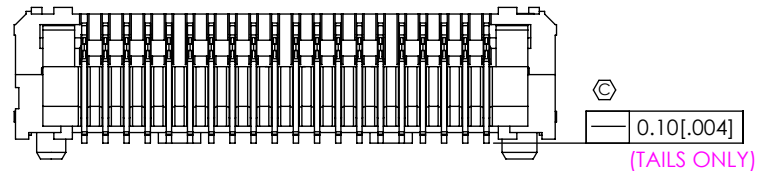

FIG 6
(IN PROCESS 3)



SECTION "D"-"D"
SCALE 3.5 : 1



BACK VIEW

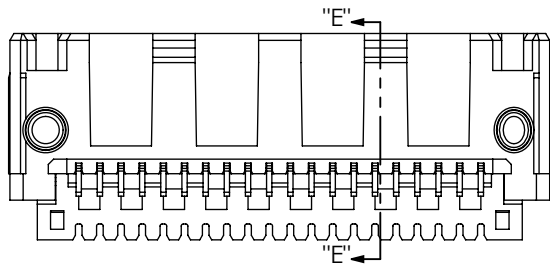
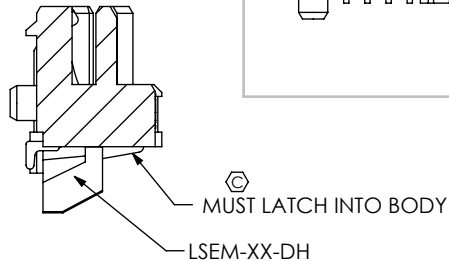

FIG 5
(IN PROCESS 2)



SECTION "E"-"E"
SCALE 3.5 : 1

PROPRIETARY NOTE
THIS DOCUMENT CONTAINS CONFIDENTIAL AND PROPRIETARY INFORMATION AND ALL DESIGN, MANUFACTURING, REPRODUCTION, USE, PATENT RIGHTS AND SALES RIGHTS ARE EXPRESSLY RESERVED BY SAMTEC, INC. THIS DOCUMENT SHALL NOT BE DISCLOSED, IN WHOLE OR PART, TO ANY UNAUTHORIZED PERSON OR ENTITY NOR REPRODUCED, TRANSFERRED OR INCORPORATED IN ANY OTHER PROJECT IN ANY MANNER WITHOUT THE EXPRESS WRITTEN CONSENT OF SAMTEC, INC.

DO NOT SCALE DRAWING
SHEET SCALE: 5:1



520 PARK EAST BLVD., NEW ALBANY, IN 47150
PHONE: 812-944-6733 FAX: 812-948-5047
PHONE: 812-944-6733 FAX: 812-948-5047

DESCRIPTION:
0.8mm HERMAPHRODITIC HORIZONTAL FOR LSEM -DH

DWG. NO.
LSEM-1XX-XX-X-DH-A-X-X-XR

BY: CHADP 04/08/2009 SHEET 3 OF 3