

P/N IN TUBE	CKT SIZE	VOID PIN LOCATION	DIMENSION				
			A	B	C	D	E
87831-1233	12	1	10.00	12.85	14.65	13.00	5.00

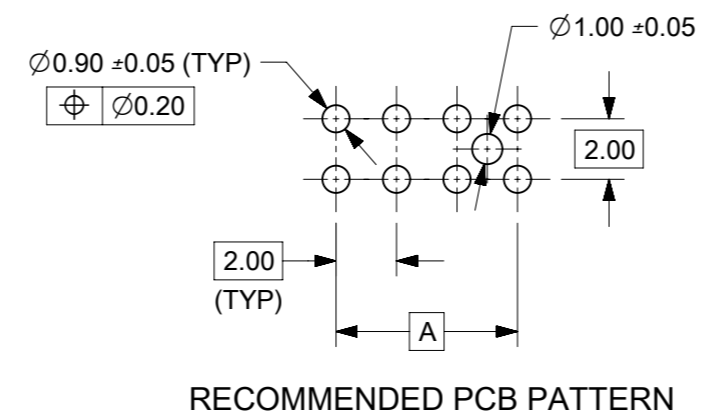

REF : ORIENTATION OF PART IN TUBE
(FOR THE REFERENCE OF PART/TUBE ASSEMBLY)

- NOTES:
- FOR ILLUSTRATION PURPOSES, 8 CIRCUIT SIZE WAFER IS SHOWN.
 - MATERIAL :
HOUSING : 30% G.F., NYLON 46, UL94V-0, COLOR BLACK.
PIN : 0.50mm SQ. PHOSPHOR BRONZE.
 - PLATING :
0.38µm/30µin GOLD IN CONTACT AREA AND 1.88µm/75µin MIN. TIN IN SOLDER TAIL AREA OVER 1.27µm/50µin MIN. NICKEL OVERALL.
 - PRODUCT SPECIFICATION PS-87831-027 APPLIES.
 - PIN PUSHOUT FORCE 0.91 kg MIN.
 - THIS HEADER MATES WITH MOLEX :
a) CRIMP RECEPTACLE HOUSING, 51110 SERIES WITH CRIMP TERMINAL, 50394 SERIES.
b) 2mm MILLIGRID DUAL ROW IDT, 87568 SERIES.
 - PARTS TO BE PACKED IN TUBE WITH MOISTURE BARRIER BAG.

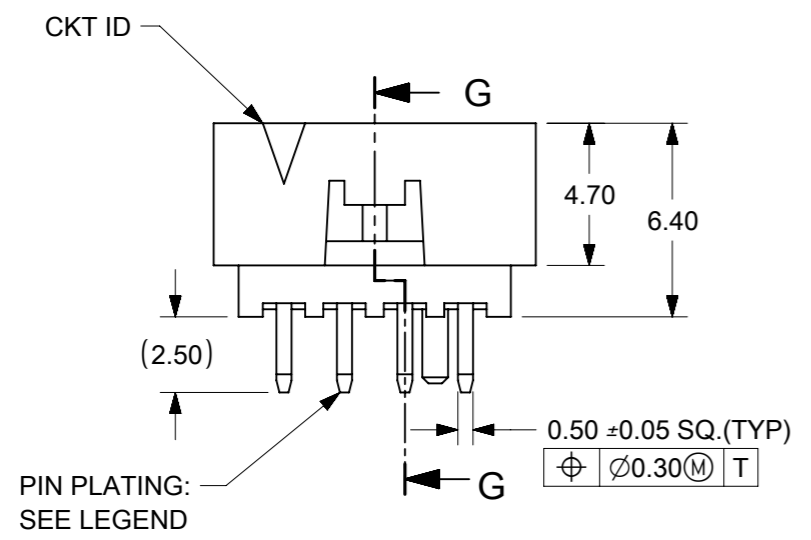
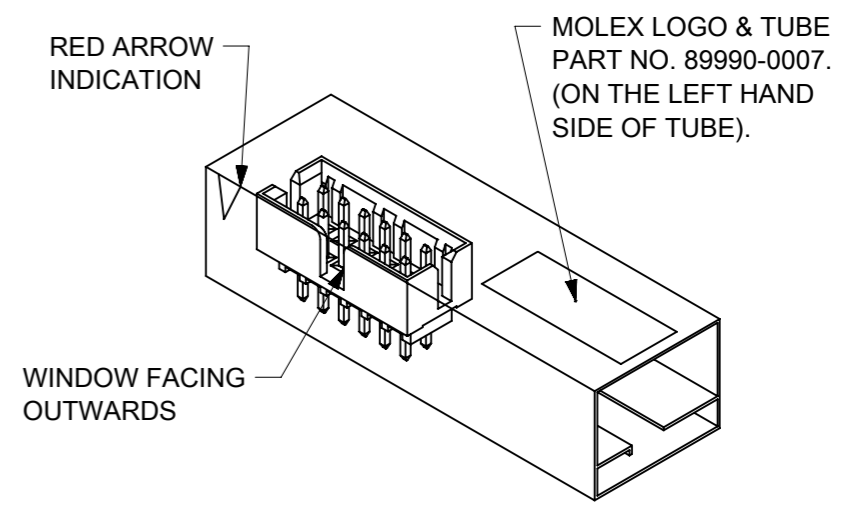
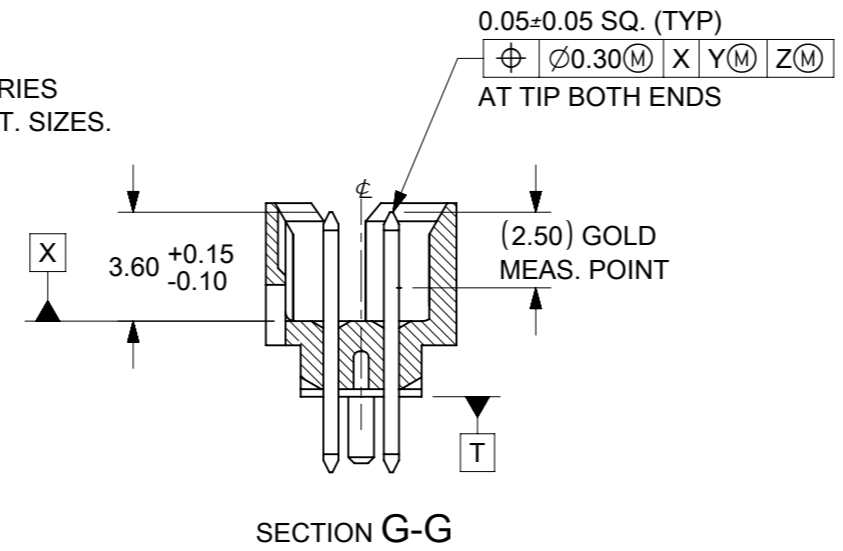
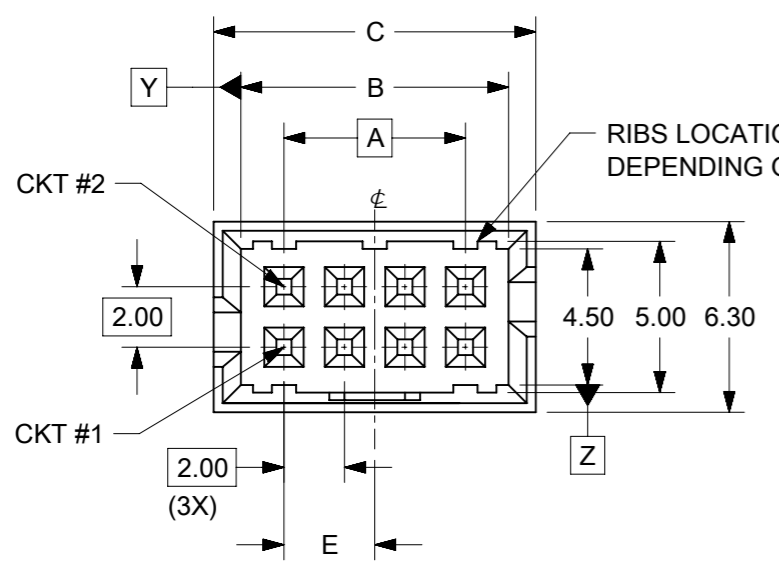
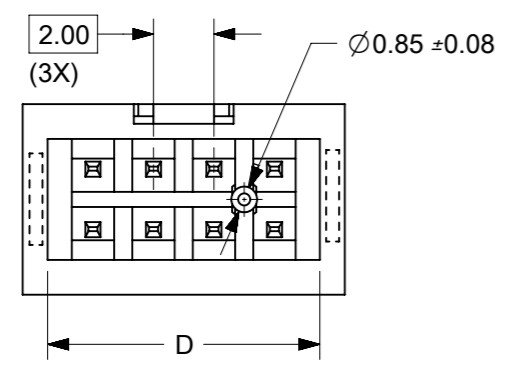

THIS DRAWING CONTAINS INFORMATION THAT IS PROPRIETARY TO MOLEX ELECTRONIC TECHNOLOGIES, LLC AND SHOULD NOT BE USED WITHOUT WRITTEN PERMISSION

ADDED BTB DIST. EC NO: 619055 DRWN: SCS02 CHK'D: NMANE02 APPR: MRAMAKRISHNA	GENERAL TOLERANCES (UNLESS SPECIFIED)		DIMENSION UNITS		SCALE				
			MM	INCH	MM	NTS			
	4 PLACES	±	±	DRWN BY	DATE		MGRID, SHROUDED HEADER VERTICAL, W/LOCK FEATURE		
	3 PLACES	±	±	ATSEE	2004/08/05				
	2 PLACES	±	0.2	±	CHK'D BY	DATE		PRODUCT CUSTOMER DRAWING	
1 PLACES	±	±	±	KCLING	2004/08/17				
0 PLACES	±	±	±	APPR BY	DATE		SERIES: 87831 MATERIAL NUMBER: SEE TABLE CUSTOMER: GENERAL MARKET		
ANGULAR TOL = 3.0		DRAWING SIZE		THIRD ANGLE PROJECTION		SKTOH 2004/08/20			
DRAFT WHERE APPLICABLE MUST REMAIN WITHIN DIMENSIONS		A3				DOCUMENT NUMBER: SD-87831-032 DOC TYPE: PSD DOC PART: 001 SHEET NUMBER: 1 OF 2			

BOARD TO BOARD (BTB) DISTANCE

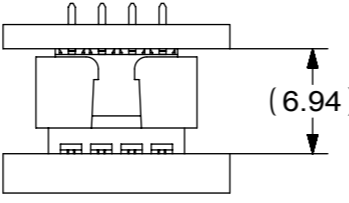
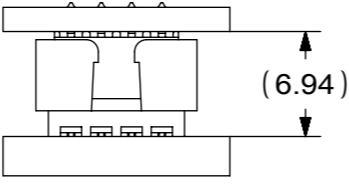
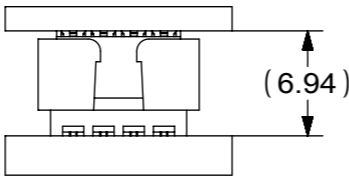
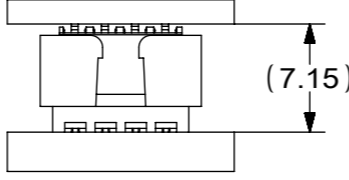
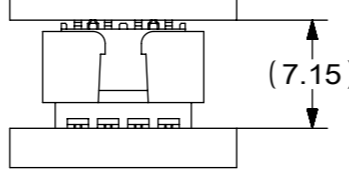
HEADER	MATES WITH (RECEPTACLE)	BTB DIST.	PICTORIAL VIEW
87831	79107	6.94	
	78787	6.94	
	79108	6.94	
	79109	7.15	
	78788	7.15	

THIS DRAWING CONTAINS INFORMATION THAT IS PROPRIETARY TO MOLEX ELECTRONIC TECHNOLOGIES, LLC AND SHOULD NOT BE USED WITHOUT WRITTEN PERMISSION			
DIMENSION UNITS		SCALE	
mm	NTS	CURRENT REV DESC: ADDED BTB DIST.	
GENERAL TOLERANCES (UNLESS SPECIFIED)		molex MGRID, SHROUDED HEADER VERTICAL, W/LOCK FEATURE PRODUCT CUSTOMER DRAWING	
	MM INCH		
4 PLACES	± ±		
3 PLACES	± ±		
2 PLACES	± 0.2 ±		
1 PLACE	± ±	EC NO: 619055 DRWN: SCS02 2018/06/19 CHK'D: NMANE02 2019/07/09 APPR: MRAMAKRISHNA 2019/07/09	
0 PLACES	± ±	INITIAL REVISION: DRWN: DRWN BY XXXX/XX/XX APPR: APPR BY XXXX/XX/XX	
ANGULAR TOL ± 3.0°		DOCUMENT NUMBER SD-87831-032	
DRAFT WHERE APPLICABLE MUST REMAIN WITHIN DIMENSIONS		THIRD ANGLE PROJECTION	DRAWING
			A3-SIZE
		SERIES	MATERIAL NUMBER
		87831	CUSTOMER
			GENERAL MARKET
			DOC TYPE DOC PART REVISION
			PSD 001 A6
			SHEET NUMBER
			2 OF 2