

REVISIONS					
P.	LTN	DESCRIPTION	DATE	DMN	APVD
B9		REVISED PER ECO-20-004256	25MAR2020	JM	DS
B10		REVISED PER PCN E-20-016603	24NOV2020	PN	DS
B11		REVISED PER ECO-21-001365	26JAN2021	DS	DS
-	-	-	-	-	-

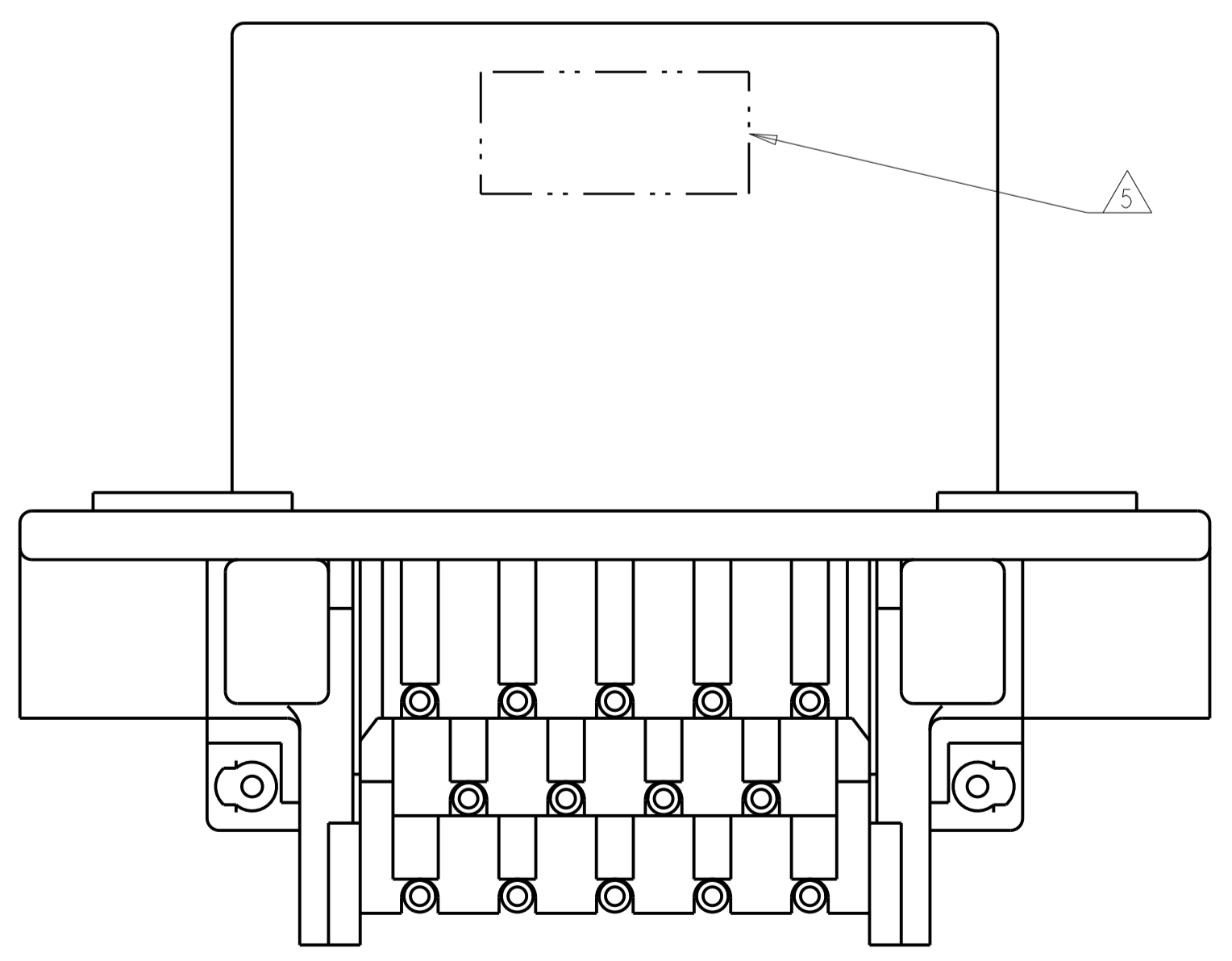
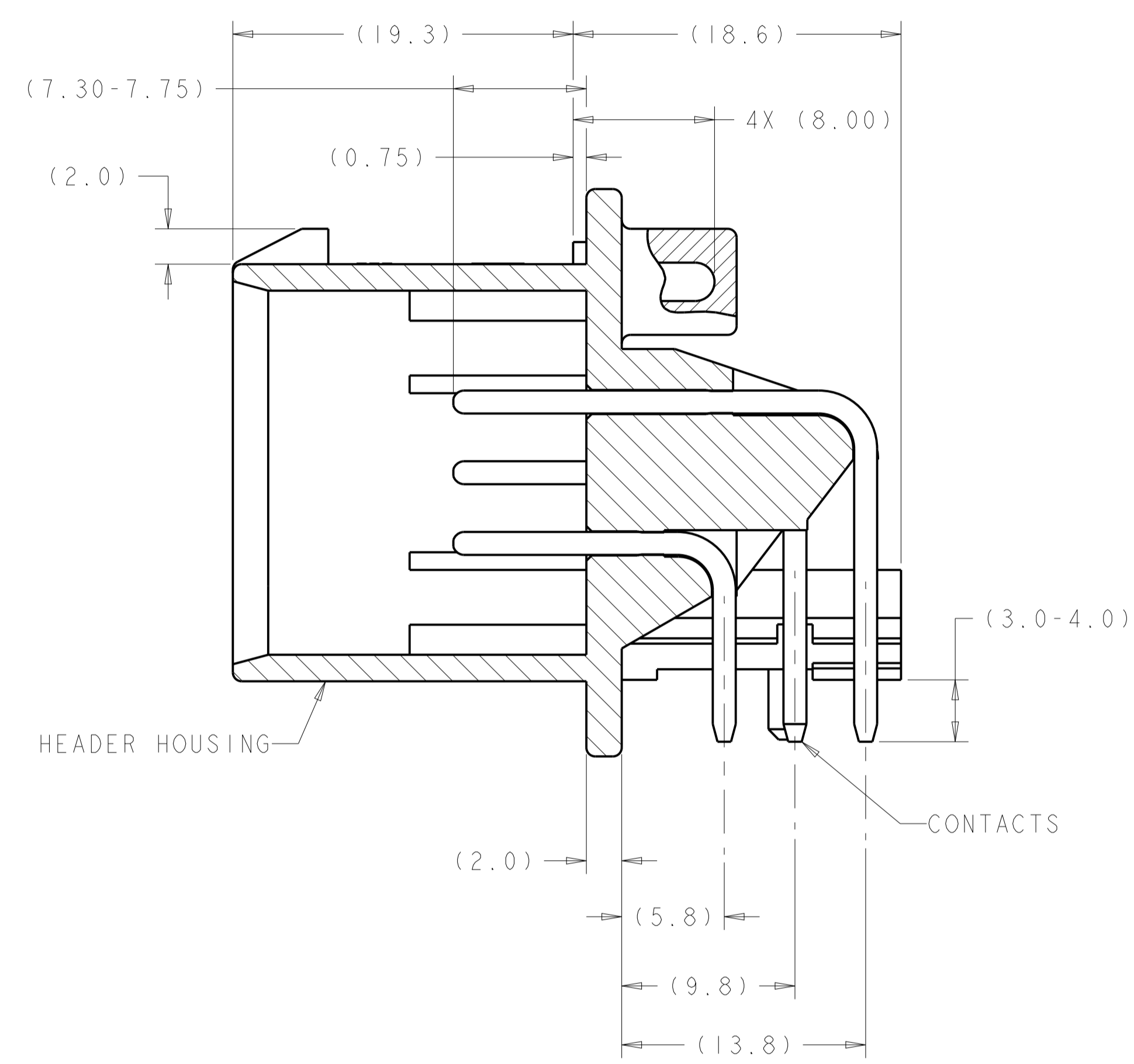
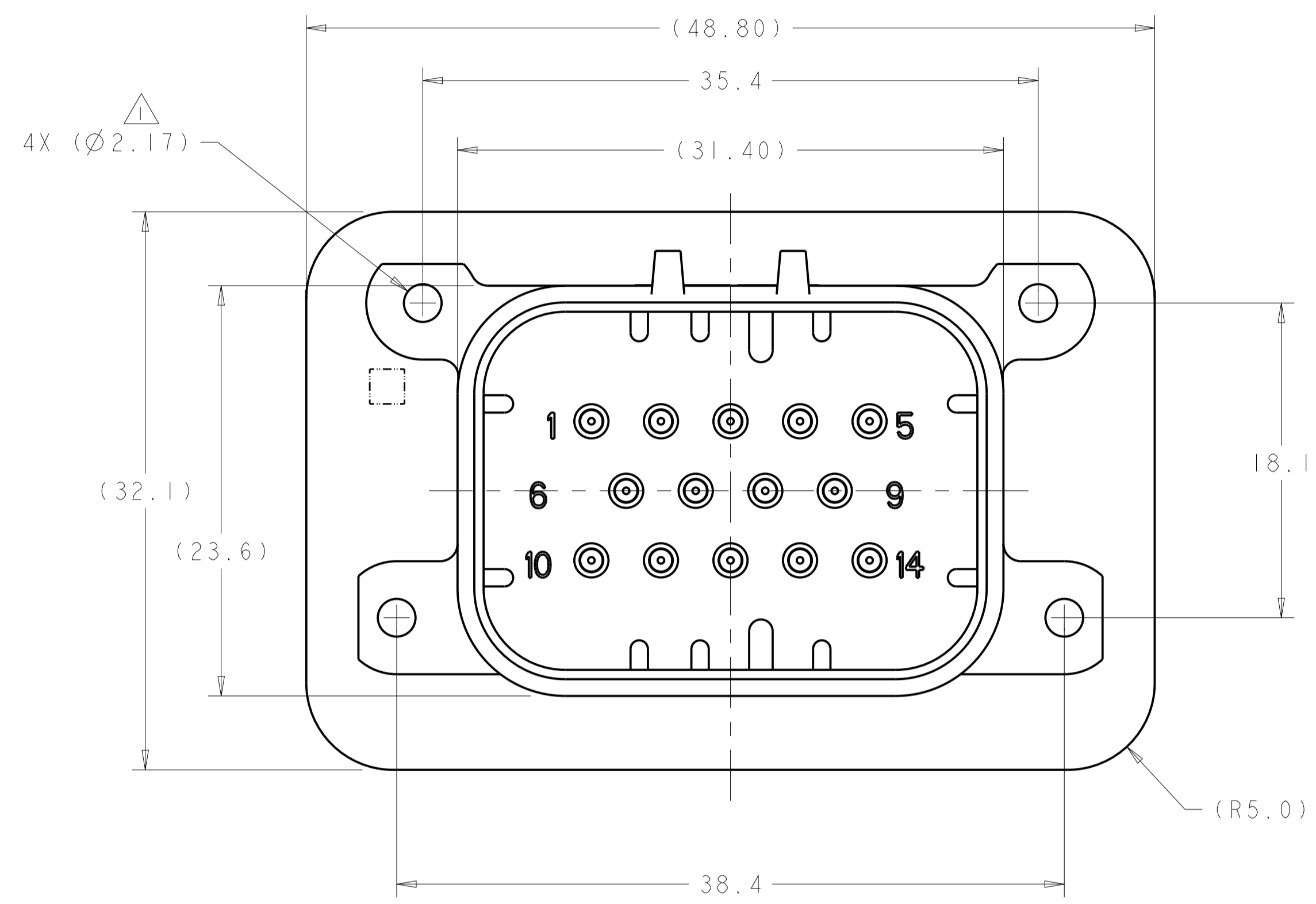

- △ SUGGESTED MOUNTING SCREW SIZE IS Ø2.50-3.00mm (Ø0.099 - 0.118 INCH) SELF TAPPING THREAD FORMING SCREW, SUCH AS DELTA PT, TO BE DRIVEN AT 0.6-0.8 N-m THE CUSTOMER SHOULD TEST THE SCREW SIZE AND TYPE IN ORDER TO VERIFY THEIR SELECTION FOR THEIR APPLICATION
- △ HOUSING COLORS ARE MECHANICALLY KEYS TO MATE ONLY WITH IDENTICALLY COLORED PLUG ASSEMBLIES.
- 3. HEADER MATES TO PLUG ASSEMBLY 776273 WHICH USES REELED TERMINAL 770520 AND LOOSE PIECE TERMINAL 770854
- △ MATERIAL: HEADER HOUSING - GLASS FILLED PBT
PIN - TIN OR GOLD PLATED BRASS
- △ DATE CODE TO BE BRANDED ON THIS SURFACE PER TE SPEC 102-60. USE 5 DIGIT CODE: FIRST 2 DIGITS = YEAR, SECOND 2 DIGITS = WEEK, LAST DIGIT = DAY.

776266-1 & 1-776266-1 SHOWN

HEADER HOUSING COLOR	DESCRIPTION	PART NUMBER
BLUE	GOLD PLATED	1-776266-5
GRAY	GOLD PLATED	1-776266-4
NATURAL	GOLD PLATED	1-776266-2
BLACK	GOLD PLATED	1-776266-1
BLUE	TIN PLATED	776266-5
GRAY	TIN PLATED	776266-4
NATURAL	TIN PLATED	776266-2
BLACK	TIN PLATED	776266-1

THIS DRAWING IS A CONTROLLED DOCUMENT.

DIMENSIONS:	TOLERANCES UNLESS OTHERWISE SPECIFIED:	DMN D. DRUMMOND 18AUG2010	CHK D. STRAUSSER 18AUG2010	APVD D. STRAUSSER 18AUG2010	NAME D. STRAUSSER
mm	0 PLC ±0.2 2 PLC ±0.13 3 PLC ±0.13 4 PLC ±0.13 ANGLES ±4°	PRODUCT SPEC 108-1329	APPLICATION SPEC 114-16016	SIZE A1	CAGE CODE 100779
MATERIAL	FINISH	WEIGHT	SCALE 4:1	SHEET 1	OF 2
CUSTOMER DRAWING		DRAWING NO 776266		REV B11	

TE Connectivity
 HEADER ASSEMBLY,
 14 POSITION, RIGHT ANGLE,
 AMPSEAL

REVISIONS				
P.	LTN.	DESCRIPTION	DATE	APP'D.
-	-	SEE SHEET 1	-	-

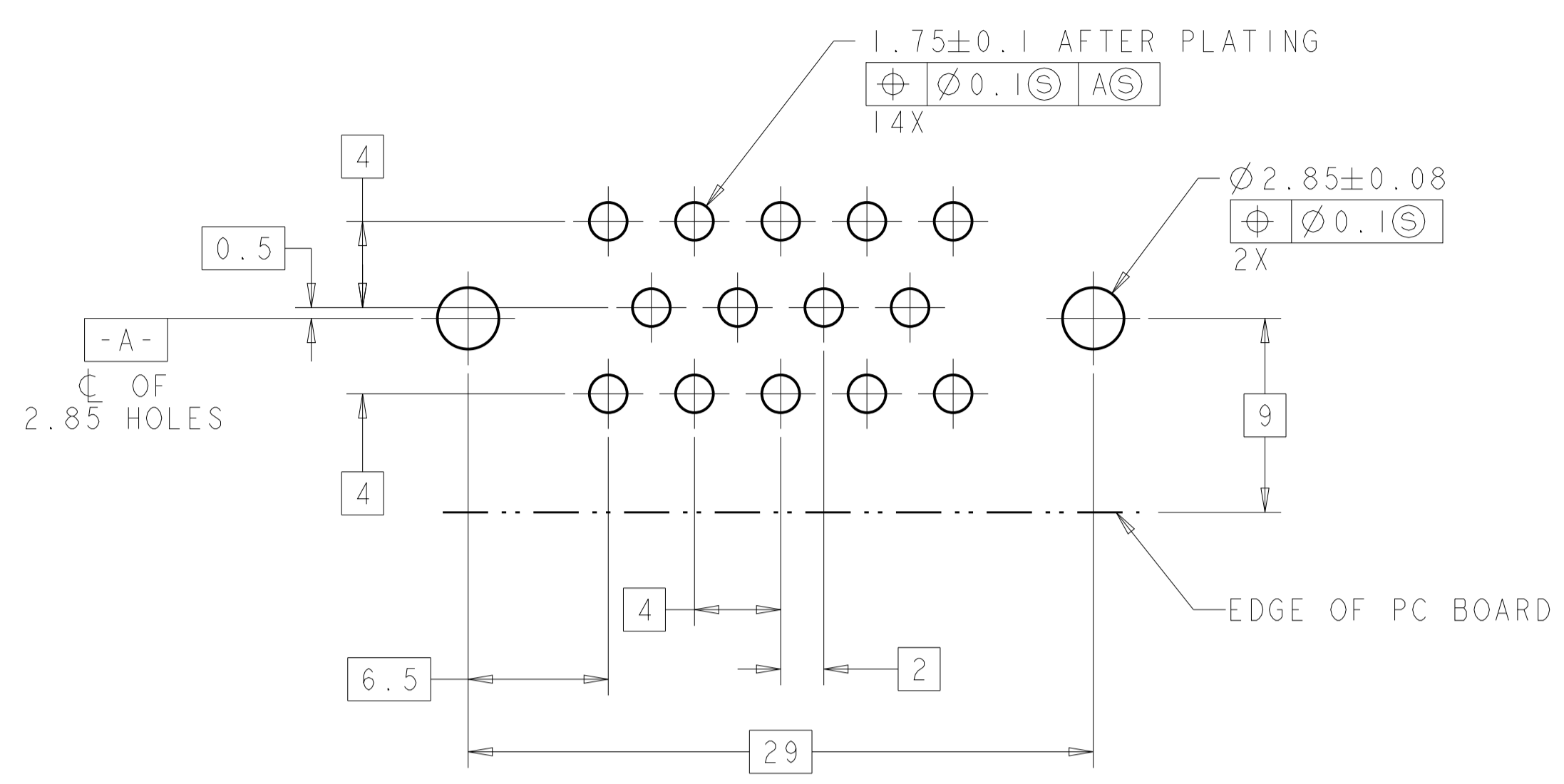

RECOMMENDED PC BOARD LAYOUT FOR 1.57 PC BOARD

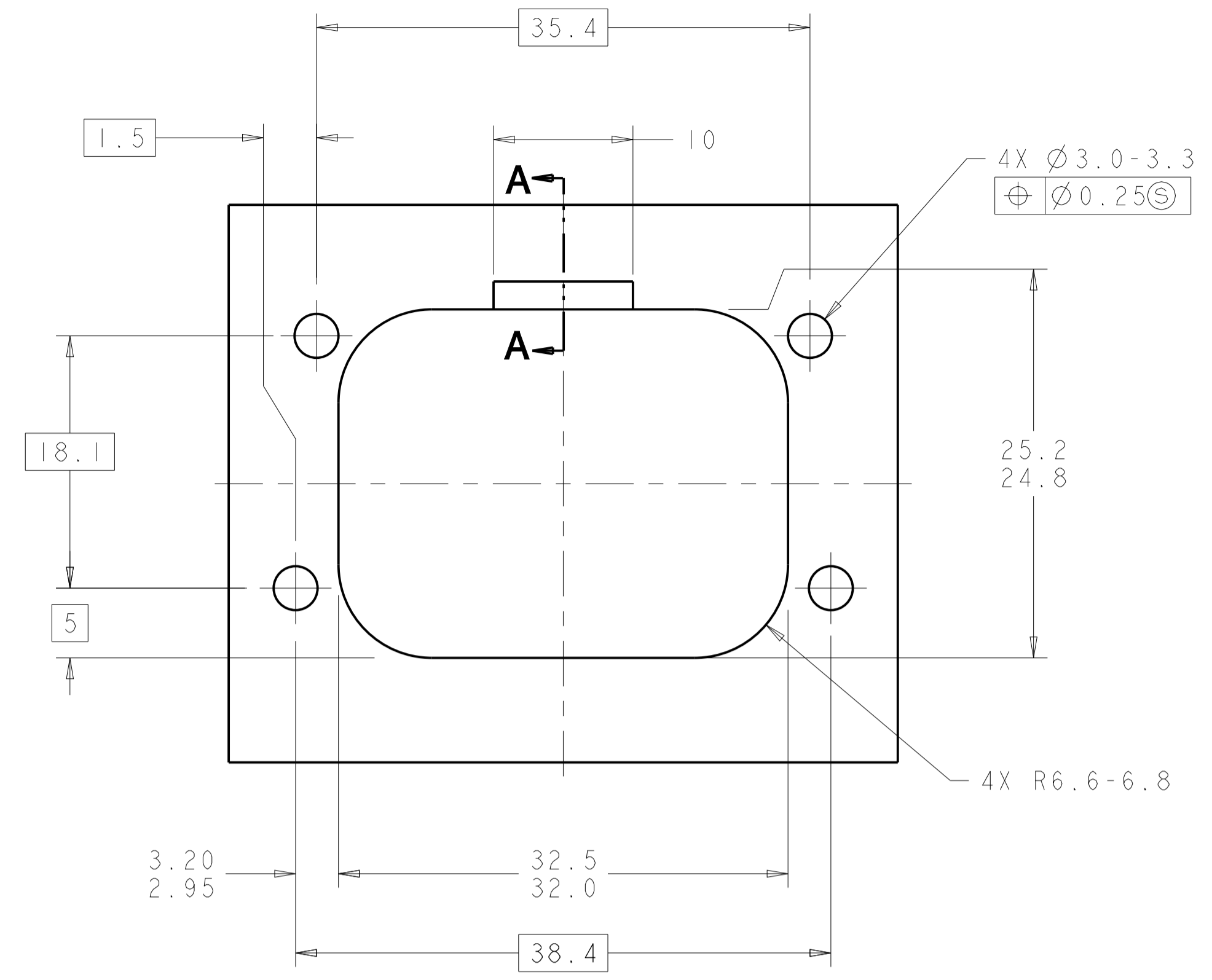

RECOMMENDED MOUNTING HOLE LAYOUT FOR 5.0 MAX THICK PANEL

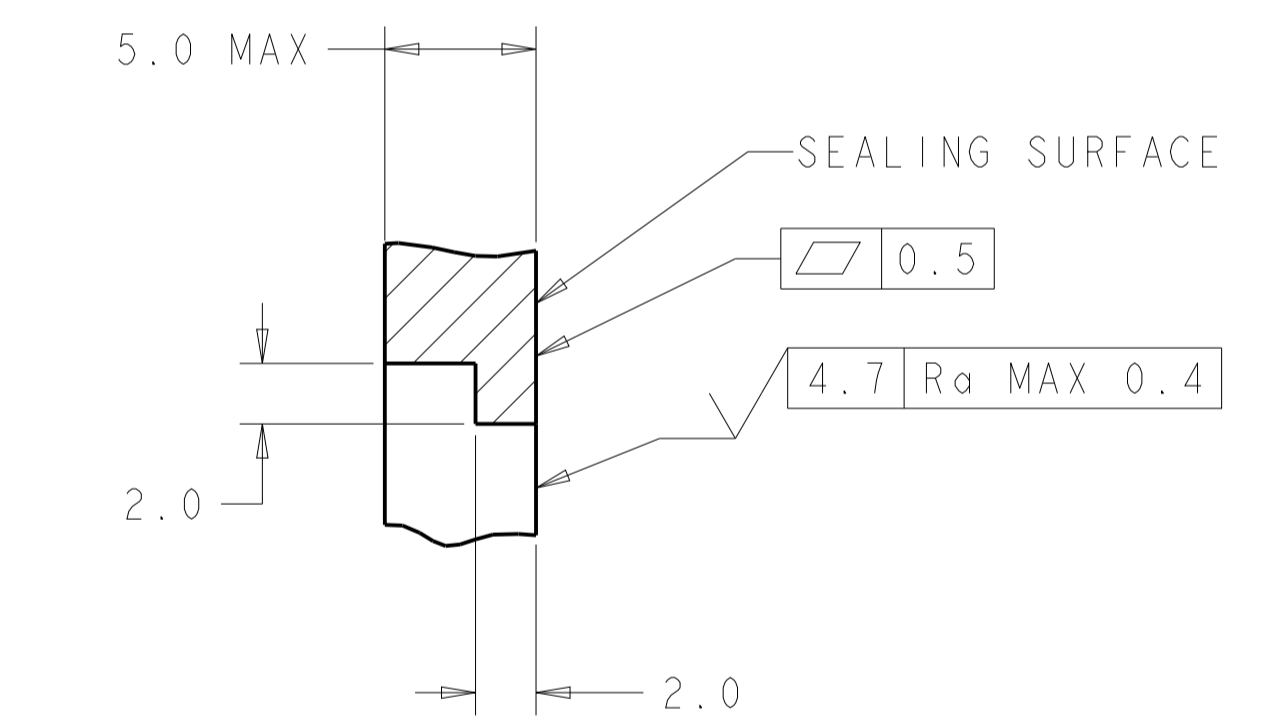
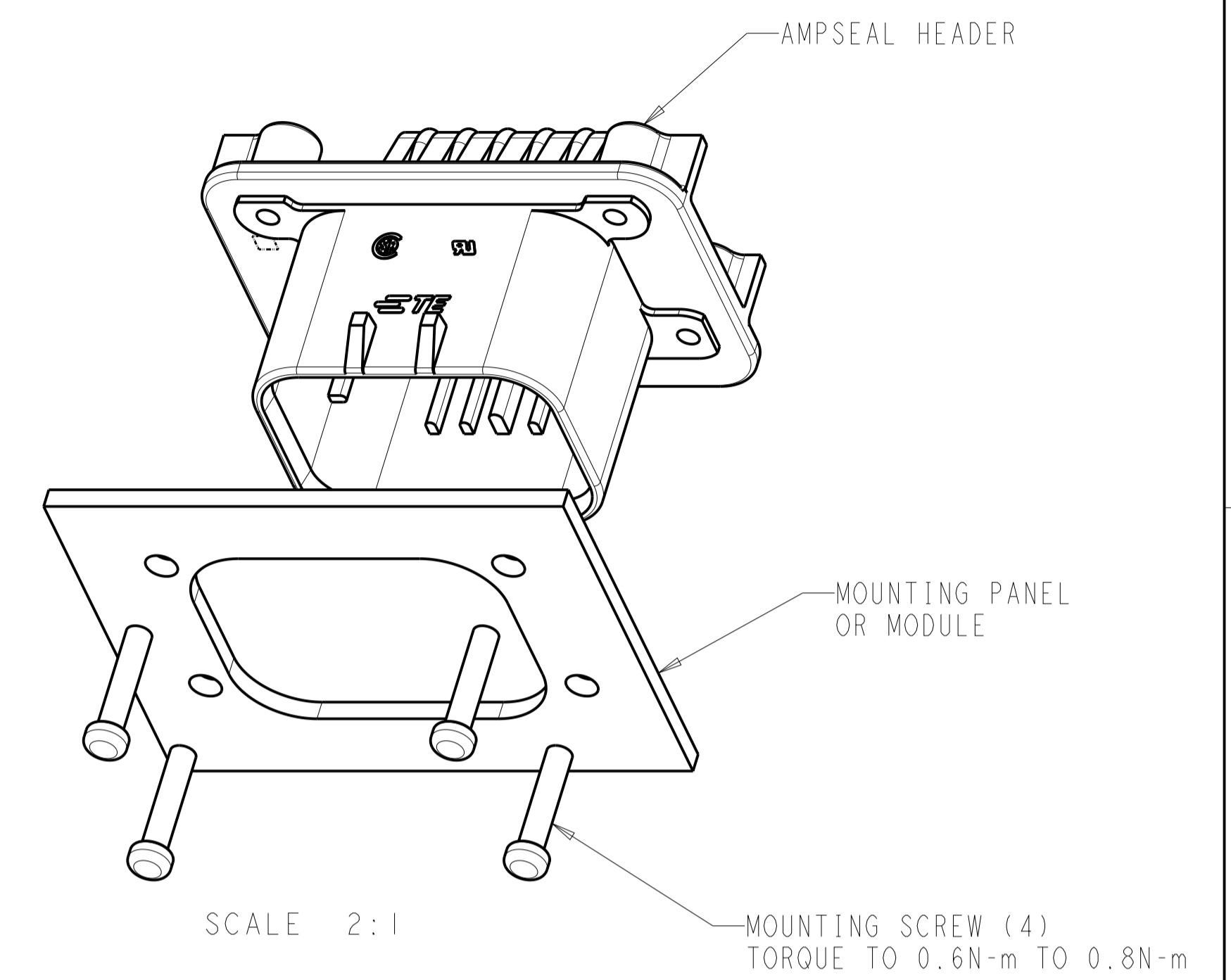

SECTION A-A
OPTIONAL CONSTRUCTION IF THICKNESS IS GREATER THEN 2.0

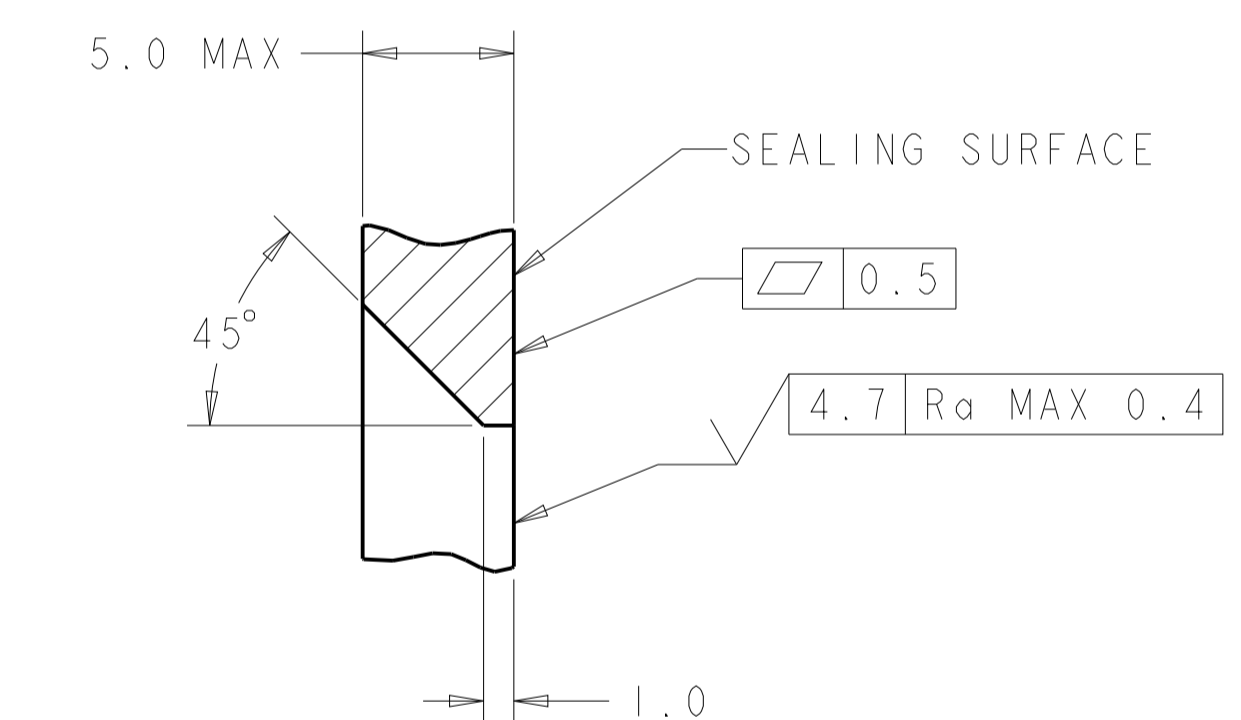

SECTION A-A
OPTIONAL CONSTRUCTION IF THICKNESS IS GREATER THEN 2.0

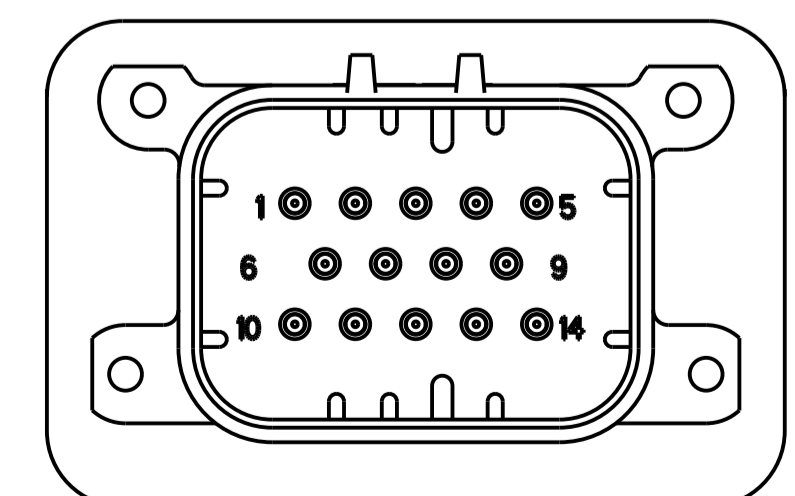
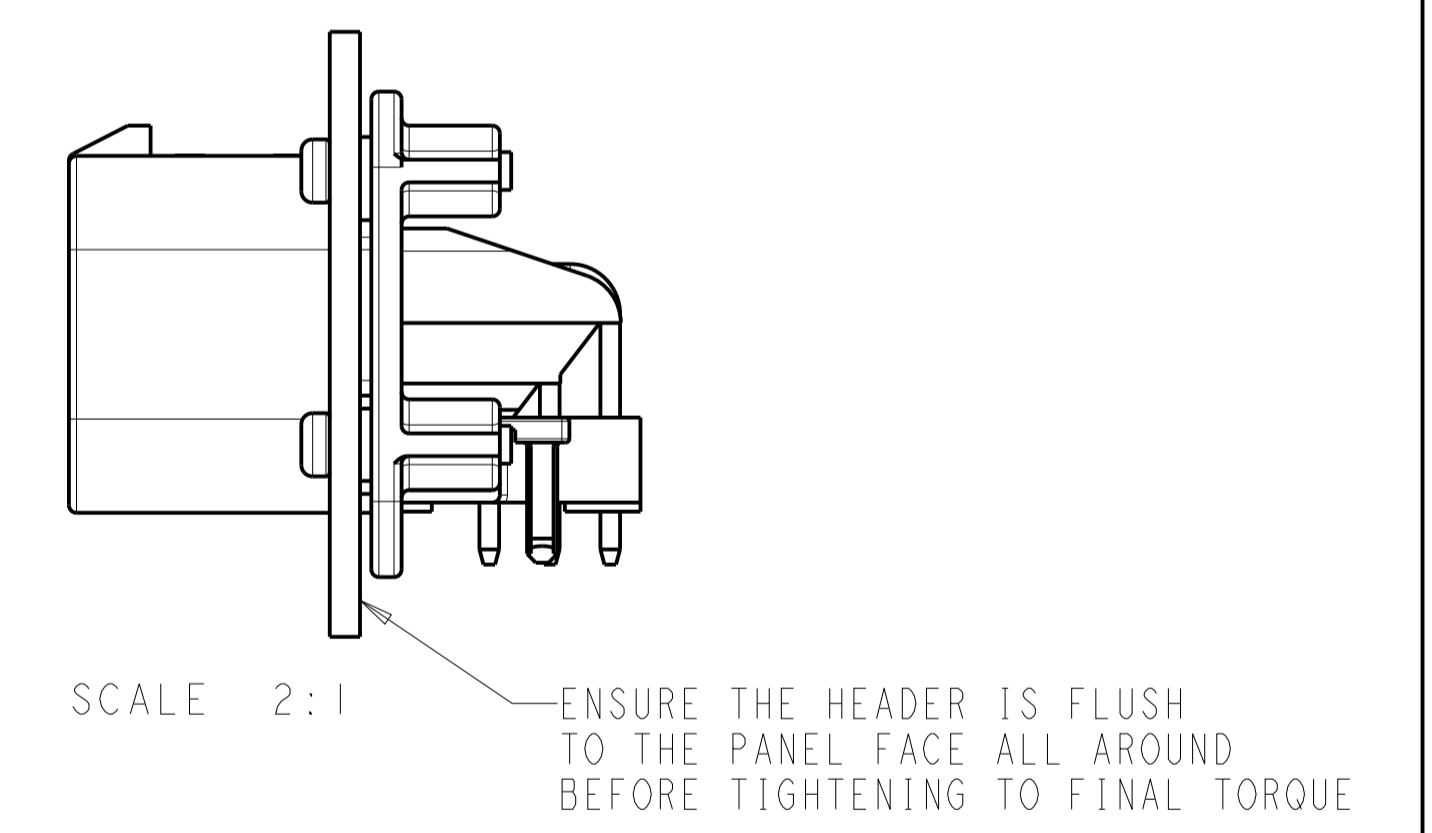

776266-1 & 1-776266-1
KEY LOCATION
SCALE 2:1

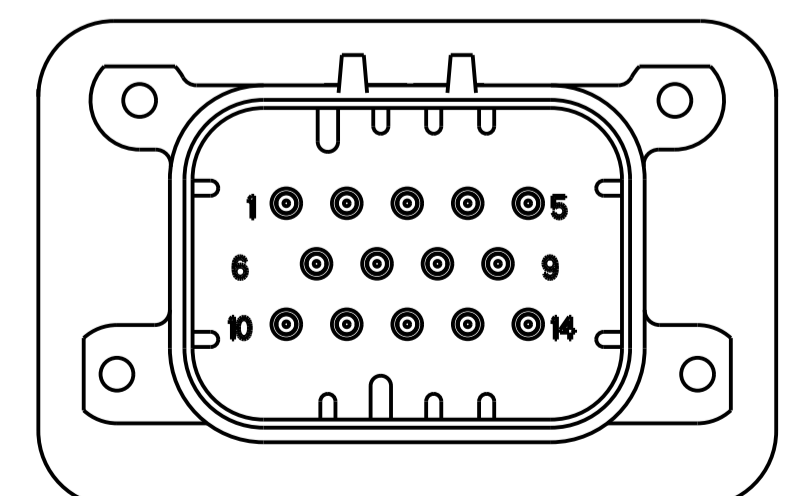

776266-2 & 1-776266-2
KEY LOCATION
SCALE 2:1

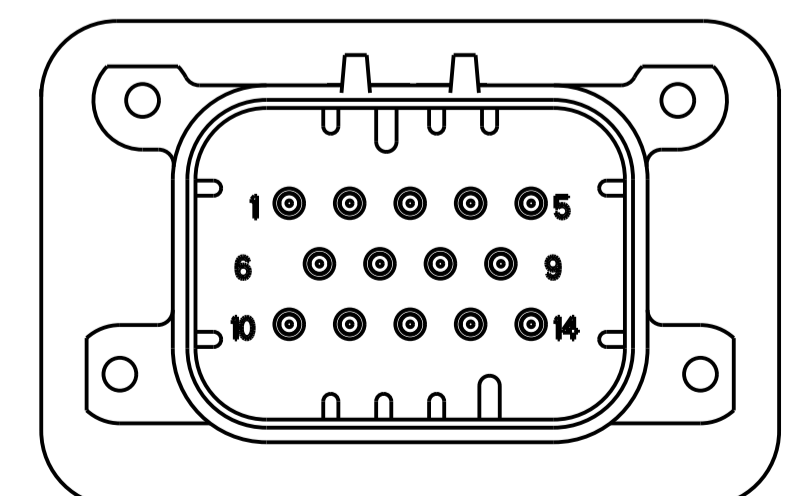

776266-4 & 1-776266-4
KEY LOCATION
SCALE 2:1

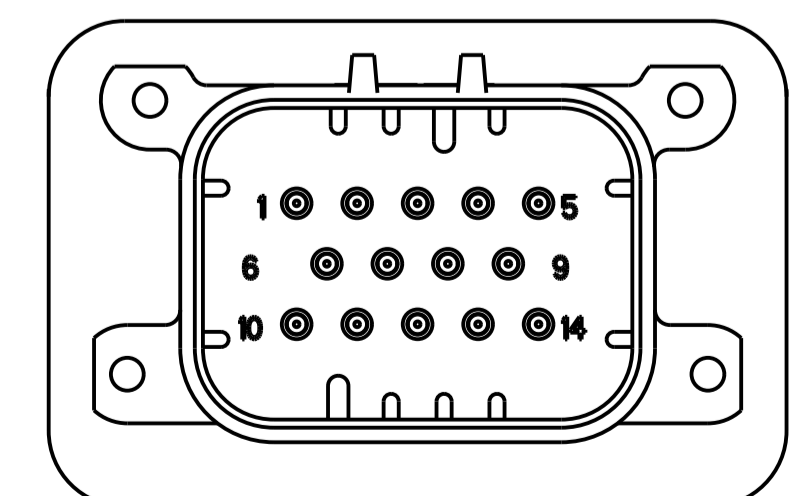

776266-5 & 1-776266-5
KEY LOCATION
SCALE 2:1

THIS DRAWING IS A CONTROLLED DOCUMENT.		OWN: D. DRUMMOND 18AUG2010	TE Connectivity
DIMENSIONS: mm		CHK: D. STRAUSSER 18AUG2010	
TOLERANCES UNLESS OTHERWISE SPECIFIED:		APVD: D. STRAUSSER 18AUG2010	NAME: HEADER ASSEMBLY, 14 POSITION, RIGHT ANGLE, AMPSEAL
0 PLC	±	PRODUCT SPEC	SIZE: CAGE CODE DRAWING NO
1 PLC	±0.2	108-1329	RESTRICTED TO
2 PLC	±0.13	APPLICATION SPEC	A100779C=776266
3 PLC	±	114-16016	SCALE 4:1 SHEET 2 OF 2
4 PLC	±	WEIGHT	REV B1
ANGLES	±	CUSTOMER DRAWING	