

SERIES

NO.OF CONTACTS

09,15,25,37

TYPE OF CONTACTS

P-PIN

TYPE OF TERMINATION

33-ANGLED SPILL

PITCH 2.84 USA

FOOT PRINT 8.08 USA

HEIGHT OF TERMINATION

E-2.00mm COMPATIBLE FOR 1.6mm PCB

**RoHS INFORMATIONS**

"This LF product meets European Union Directives and other country regulations as described in GS-22-008"

The housing will withstand exposure to 260°C peak temperature for 30 seconds in a convection,infra-red or vapor reflow oven solder application.

Packaging as per GS-14-920

**PRODUCT SPECIFICATION**

See :- GS-12-433

**PACKAGING SPECIFICATION**

See :- GS-14-1157

SEE NOTE RoHS

PACKAGING SPECIFICATION

09-TRAY PACKAGING

MOUNTING OPTIONS

RV->LIF METAL PEG+F.SCREW LOCK UNC 4 40+METAL BRACKET

RL->LIF METAL PEG+ INSERT M3+METAL BRACKET

RX->LIF METAL PEG+ INSERT UNC 4-40 +METAL BRACKET

PLATING

6-500 Mating/Un-mating performance

|                              |  |                |  |                       |  |                               |  |                |  |                                       |  |                          |  |
|------------------------------|--|----------------|--|-----------------------|--|-------------------------------|--|----------------|--|---------------------------------------|--|--------------------------|--|
| mat'l. code<br>SEE.TECH.SPEC |  |                |  | surface<br>ISO 1302 ✓ |  | tolerance<br>ISO 406 ISO 1101 |  | projection<br> |  | product family<br>DELTA-D             |  |                          |  |
| ltr                          |  |                |  | ecn no                |  | dr                            |  | date           |  | tolerances unless otherwise specified |  | title                    |  |
| A                            |  |                |  | 107-0167              |  | AS                            |  | 2007-12-04     |  | angles                                |  | linear                   |  |
| B                            |  |                |  | 107-0175              |  | AS                            |  | 2008-12-23     |  | 0°±1°                                 |  | .00±0.1                  |  |
| C                            |  |                |  | 109-0162              |  | AS                            |  | 2009-08-19     |  | .000±.00X                             |  | scale -                  |  |
|                              |  |                |  | dr                    |  | ANSH.SALAM                    |  | 2007-12-04     |  |                                       |  | product family           |  |
|                              |  |                |  | enr                   |  | ANSH.SALAM                    |  | 2009-08-19     |  |                                       |  | sheet 1 of 2             |  |
|                              |  |                |  | chr                   |  | ANSH.SALAM                    |  | 2009-08-19     |  |                                       |  | size                     |  |
|                              |  |                |  | appd                  |  | BIJUK.PAUL                    |  | 2009-08-19     |  |                                       |  | A3                       |  |
| sheet index                  |  | revision sheet |  | C                     |  | C                             |  |                |  |                                       |  | type                     |  |
|                              |  |                |  | 1                     |  | 2                             |  |                |  |                                       |  | Product Customer Drawing |  |

|       |       |       |       |       |                                     |
|-------|-------|-------|-------|-------|-------------------------------------|
| 37    | 69.32 | 63.50 | 55.30 | 49.68 | 5.70 <sup>+0.25</sup> <sub>-0</sub> |
| 25    | 53.03 | 47.04 | 38.84 | 33.12 | 5.70 <sup>+0.25</sup> <sub>-0</sub> |
| 15    | 39.14 | 33.32 | 25.12 | 19.18 | 5.90 <sup>+0.15</sup> <sub>-0</sub> |
| 09    | 30.81 | 24.99 | 16.79 | 10.96 | 5.90 <sup>+0.15</sup> <sub>-0</sub> |
| SHELL | A     | B     | D     | E     | G                                   |

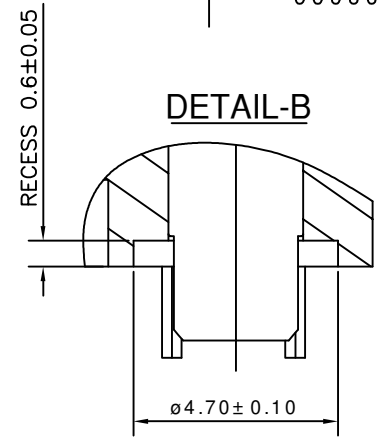
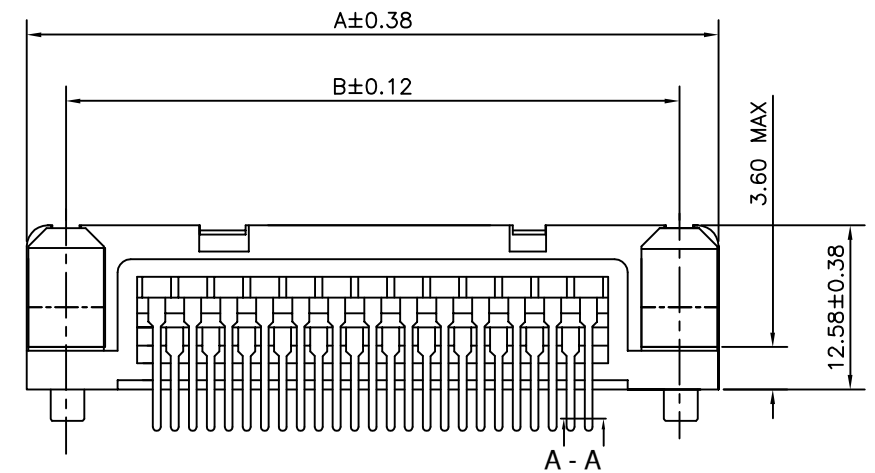
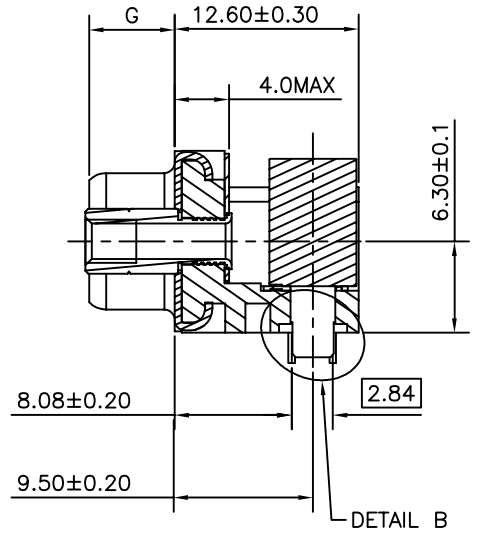
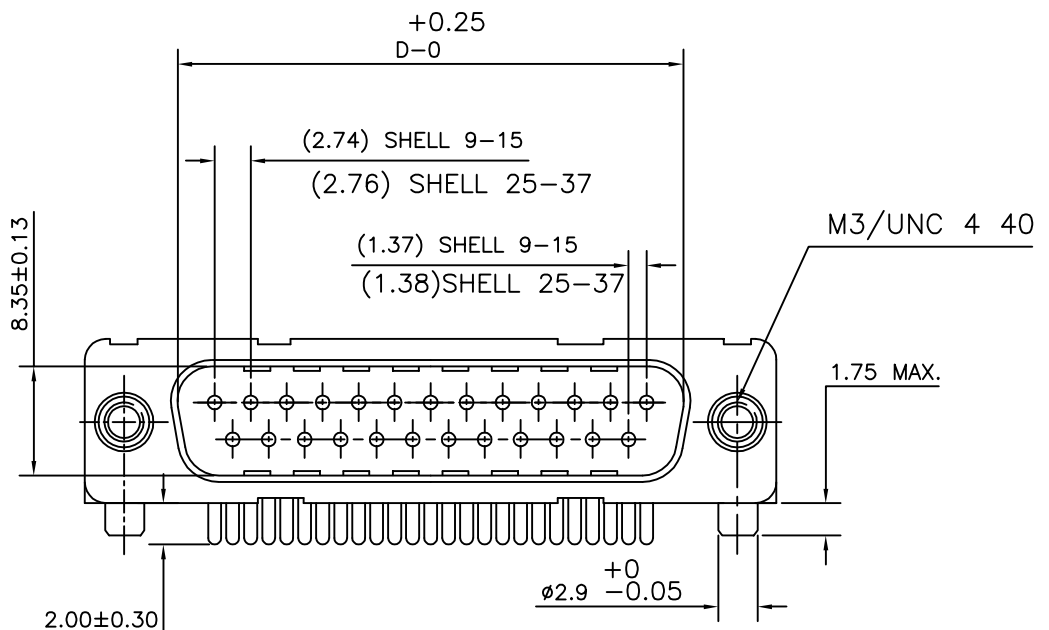
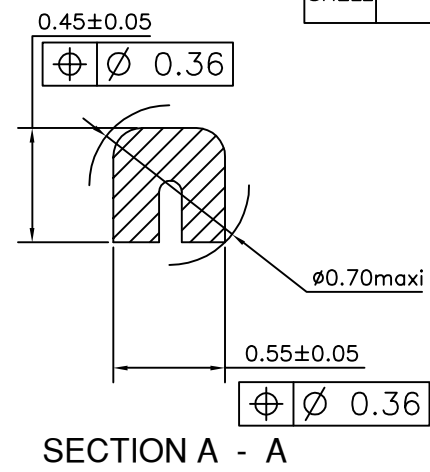
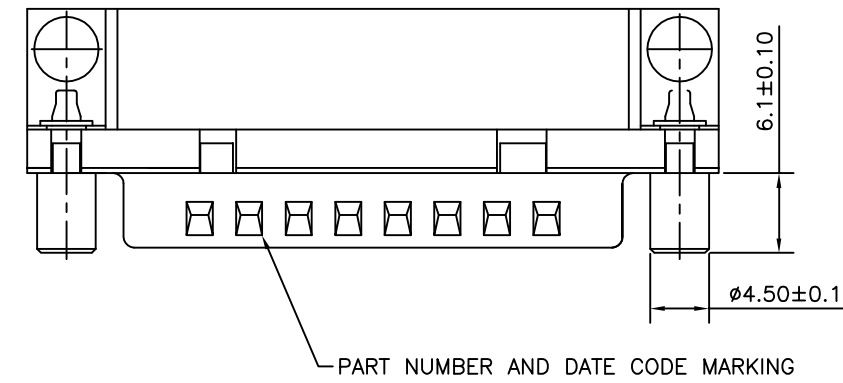
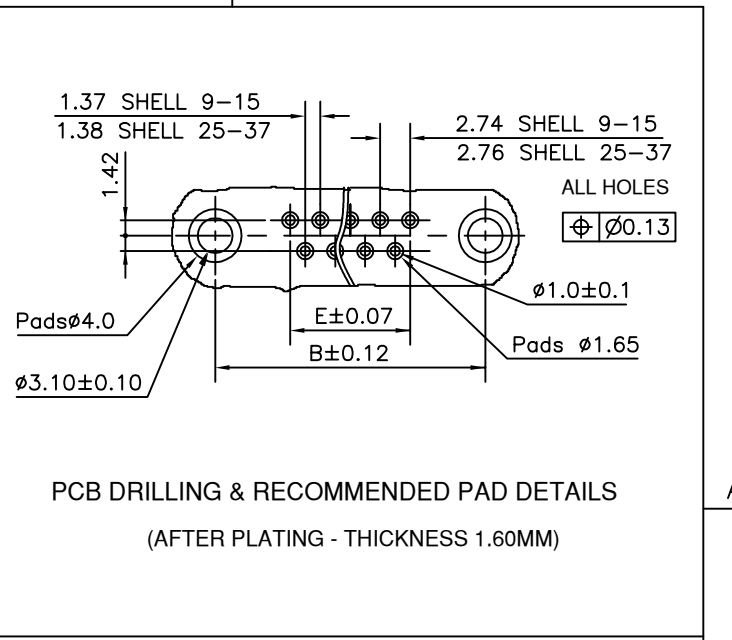

ACCESSORIES DETAILS

TRUE POSITIONING : Ø 0.36

RV VERSION

RX/RL VERSION

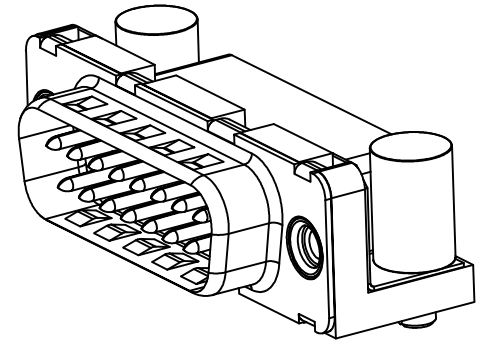
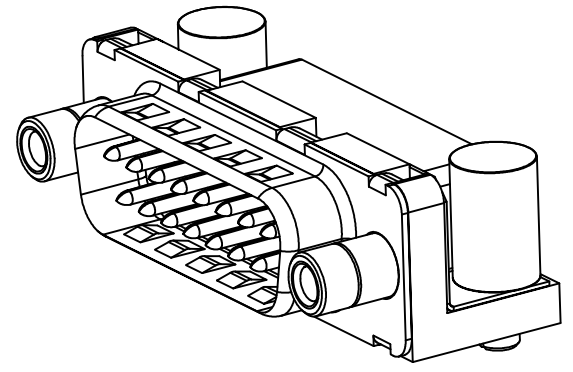

|                              |  |          |  |                       |  |                               |  |                  |  |   |  |
|------------------------------|--|----------|--|-----------------------|--|-------------------------------|--|------------------|--|---|--|
| mat'l. code<br>SEE.TECH.SPEC |  |          |  | surface<br>ISO 1302 ✓ |  | tolerance<br>ISO 406 ISO 1101 |  | projection<br>MM |  | product family<br>DELTA-D                             |  |
| ltr                          |  |          |  | ecn no                |  | dr                            |  | date             |  | title<br>DELTA-D A/S MALE PIP CONNECTOR<br>US VERSION |  |
| A                            |  |          |  | 107-0167              |  | AS                            |  | 2007-12-04       |  | angles  |  |
| B                            |  |          |  | 107-0175              |  | AS                            |  | 2008-12-23       |  | linear  |  |
| C                            |  |          |  | 109-0162              |  | AS                            |  | 2009-08-19       |  | 0°±1°   |  |
|                              |  |          |  |                       |  |                               |  |                  |  | .00±0.1   |  |
|                              |  |          |  |                       |  |                               |  |                  |  | .000±.00X   |  |
|                              |  |          |  |                       |  |                               |  |                  |  | scale -   |  |
|                              |  |          |  |                       |  |                               |  |                  |  | dr  |  |
|                              |  |          |  |                       |  |                               |  |                  |  | ANSHSALAM   |  |
|                              |  |          |  |                       |  |                               |  |                  |  | 2007-12-04  |  |
|                              |  |          |  |                       |  |                               |  |                  |  | engr  |  |
|                              |  |          |  |                       |  |                               |  |                  |  | ANSHSALAM   |  |
|                              |  |          |  |                       |  |                               |  |                  |  | 2009-08-19  |  |
|                              |  |          |  |                       |  |                               |  |                  |  | chr   |  |
|                              |  |          |  |                       |  |                               |  |                  |  | ANSHSALAM   |  |
|                              |  |          |  |                       |  |                               |  |                  |  | 2009-08-19  |  |
|                              |  |          |  |                       |  |                               |  |                  |  | appd  |  |
|                              |  |          |  |                       |  |                               |  |                  |  | BUUK.PAUL   |  |
|                              |  |          |  |                       |  |                               |  |                  |  | 2009-08-19  |  |
| sheet                        |  | revision |  | C                     |  | C                             |  |                  |  | dwg no  |  |
| index                        |  | sheet    |  | 1                     |  | 2                             |  |                  |  | sheet 2 of 2  |  |
|                              |  |          |  |                       |  |                               |  |                  |  | size  |  |
|                              |  |          |  |                       |  |                               |  |                  |  | 5   |  |
|                              |  |          |  |                       |  |                               |  |                  |  | A3  |  |
|                              |  |          |  |                       |  |                               |  |                  |  | type  |  |
|                              |  |          |  |                       |  |                               |  |                  |  | Product Customer Drawing                              |  |

FCI  
FCIconnect.com  
Copyright FCI