

MATERIAL: 11 GA. STEEL

FINISH: SMOOTH BLACK

PART No	A	B	C	D	E
1866-AB	10.468	1.484	2.250	18	10.000
1865-AB	8.718	1.484	—	15	8.250
1864-AB	6.968	1.484	—	12	6.500
1863-AB	5.218	1.484	—	9	4.750
1862-AB	3.468	0.234	—	6	3.000
1861-AB	1.718	0.234	—	3	1.250

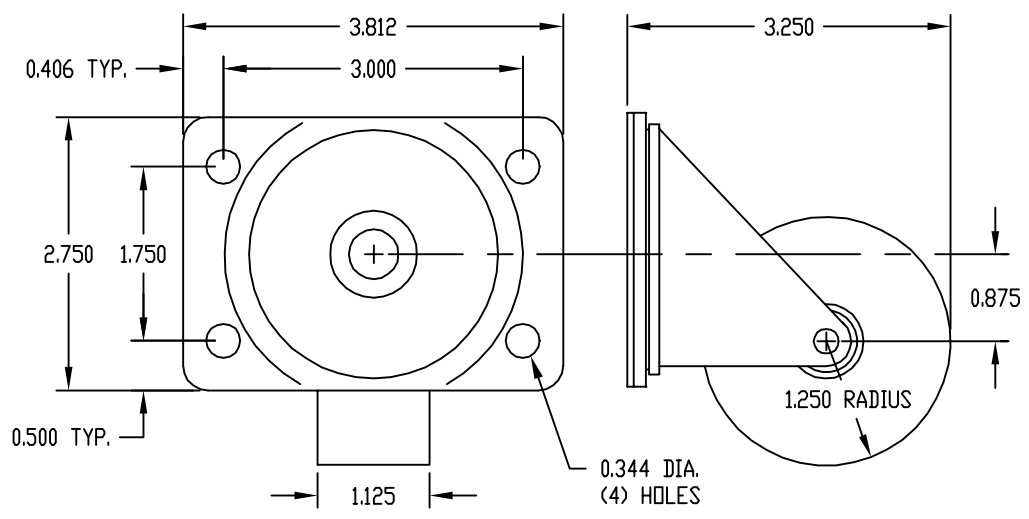

LOAD RATING:
 200LBS. EACH
 WHEELS ARE OF HARD COMPOSITION
 & SELF LUBRICATING

SWIVEL RADIUS: 2.125