

- △ HOUSING MATERIAL: GLASS FILLED POLYESTER, COLOR: BLACK
- △ CONTACT FINISH: NICKEL PLATE, .00127 [.000050] MIN, ALL OVER
 MATTE TIN PLATE, .00254 [.000100] MIN ON SOLDER POSTS,
 GOLD PLATE, .00076 [.000030] MIN IN MATING INTERFACE
- △ AMP PART NUMBER AND DATE CODE MARKED IN APPROXIMATE AREA SHOWN
- △ NO BURRS AND/OR SHARP EDGES ARE PERMISSABLE

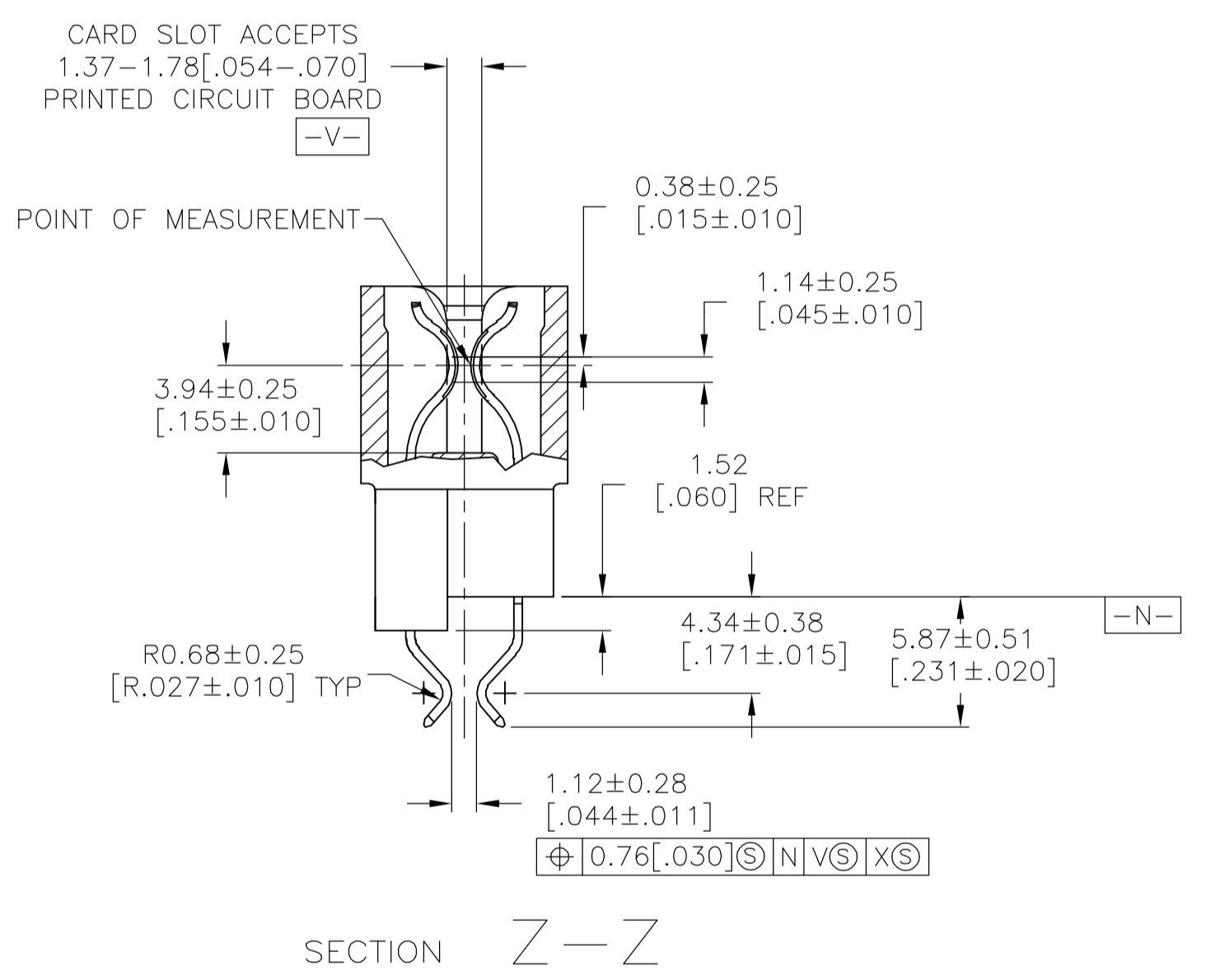
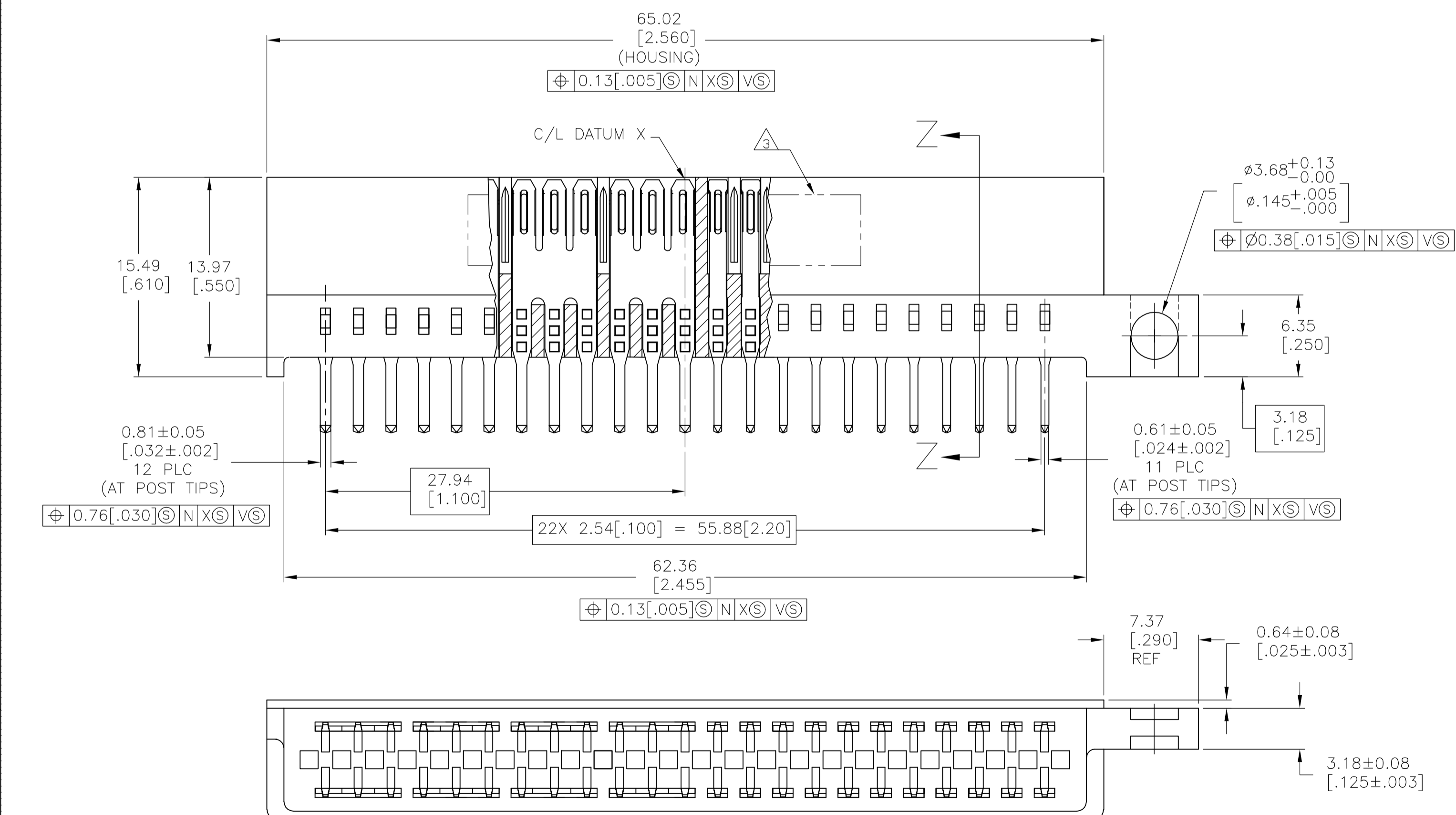

| | | |
|------------------------|--------------------------|-------------|
| 11 | 4 | 1888143-1 |
| NO OF SINGLE POSITIONS | NO OF MULTIPLE POSITIONS | PART NUMBER |

THIS DRAWING IS A CONTROLLED DOCUMENT.

| | | | | | |
|----------------------------|--|--|--|---|---|
| DIMENSIONS: MM (inches) | TOLERANCES UNLESS OTHERWISE SPECIFIED: 0 PLC ± - 1 PLC ± - 2 PLC ± 0.13 [.005] 3 PLC ± - 4 PLC ± - ANGLES ± 1° | APVD: AL FRANTUM / S. FLICKINGER 22JUNE2006 | NAME: AL FRANTUM / S. FLICKINGER 22JUNE2006 | tyco Electronics | Tyco Electronics Corporation Harrisburg, PA 17105-3608 |
| SEE NOTE 1 | SEE NOTE 2 | PRODUCT SPEC: 108-2208 | APPLICATION SPEC: - | CONNECTOR ASSEMBLY, SEC II POWER CARD EDGE, DUAL POSITION, 2.54 [.100] CENTERLINE | RESTRICTED TO: - |
| | | SIZE: A1 | SCALE: 4:1 | WEIGHT: - | CUSTOMER DRAWING |

SCALE 4:1 SHEET 1 OF 2 REV B

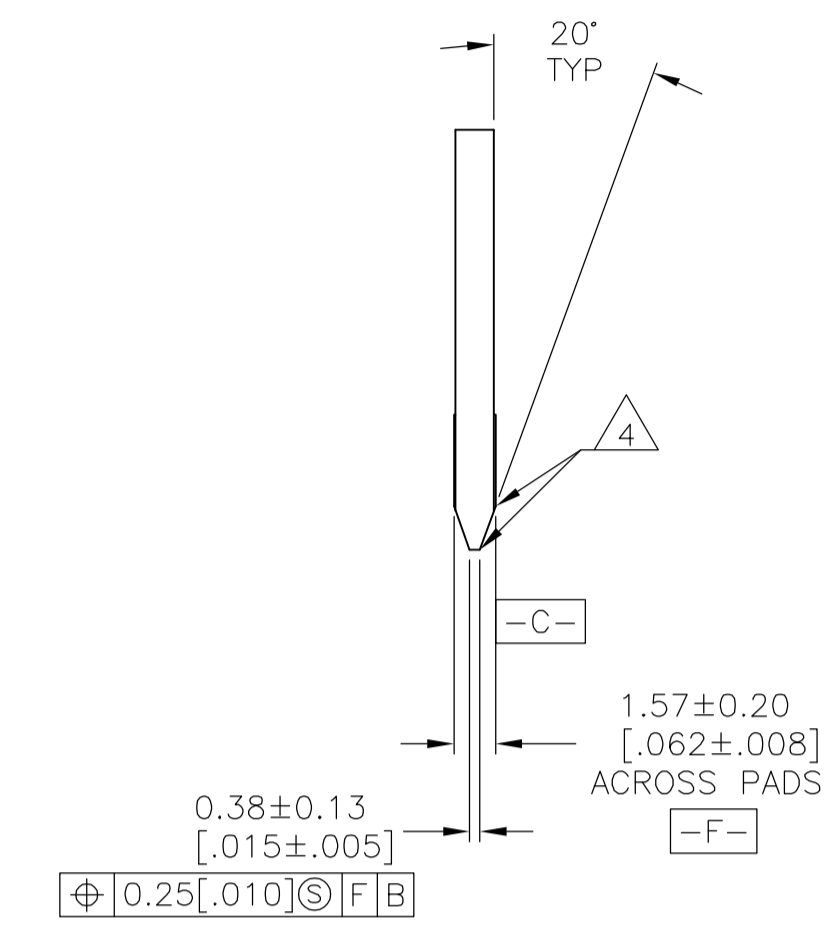
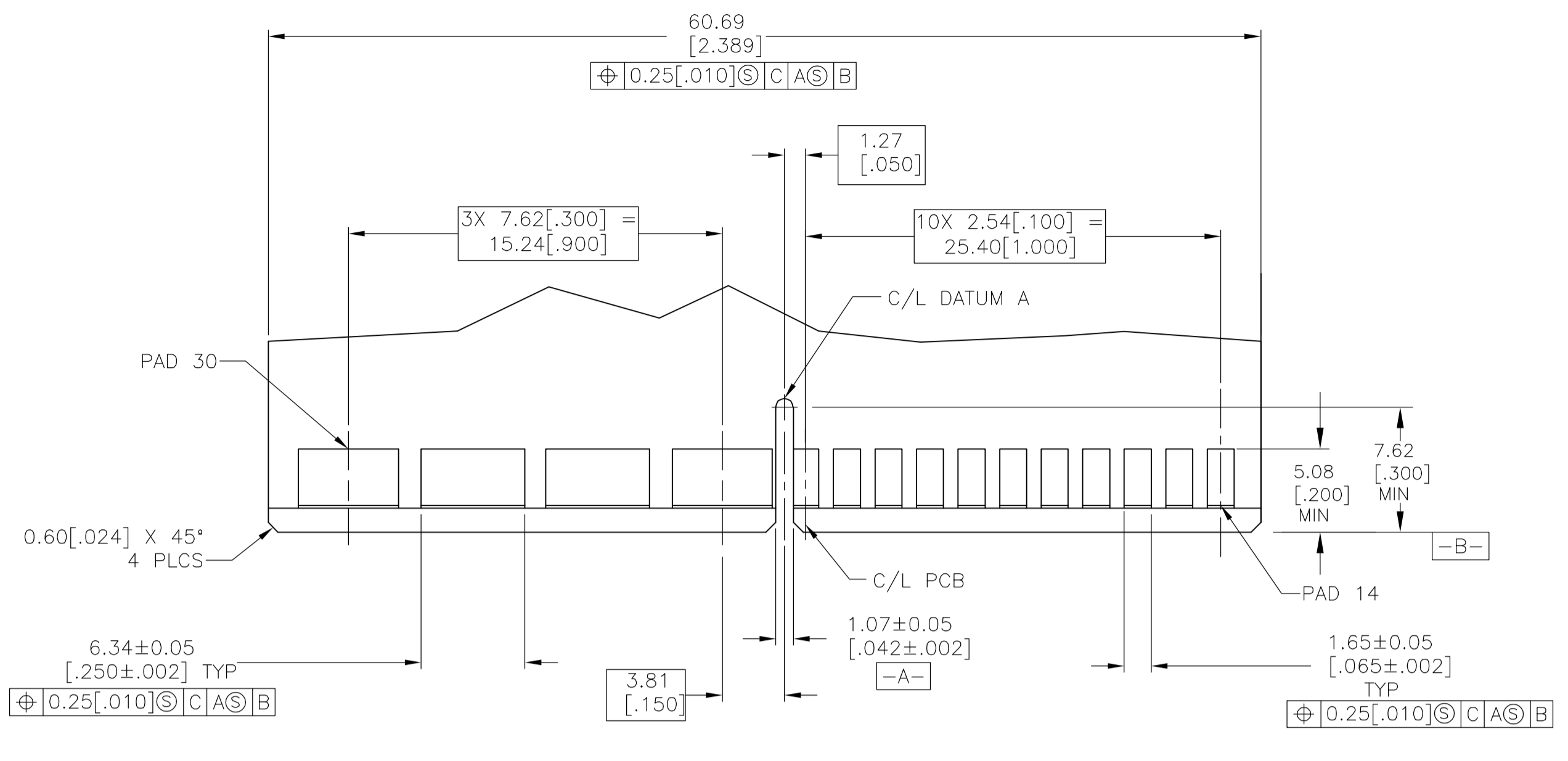

RECOMMENDED MATING BOARD EDGE CONFIGURATION
 TYP BOTH SIDES

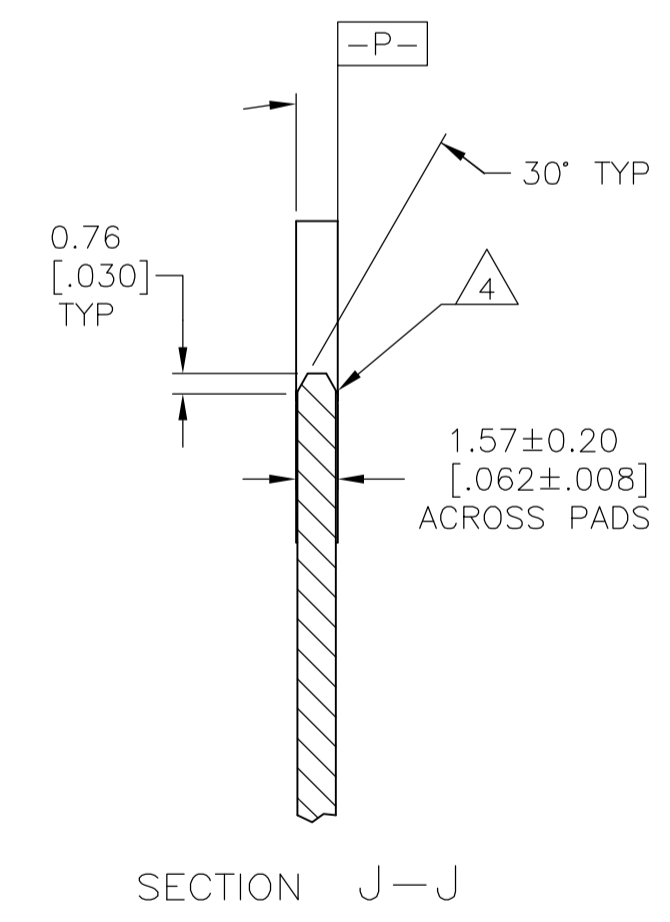
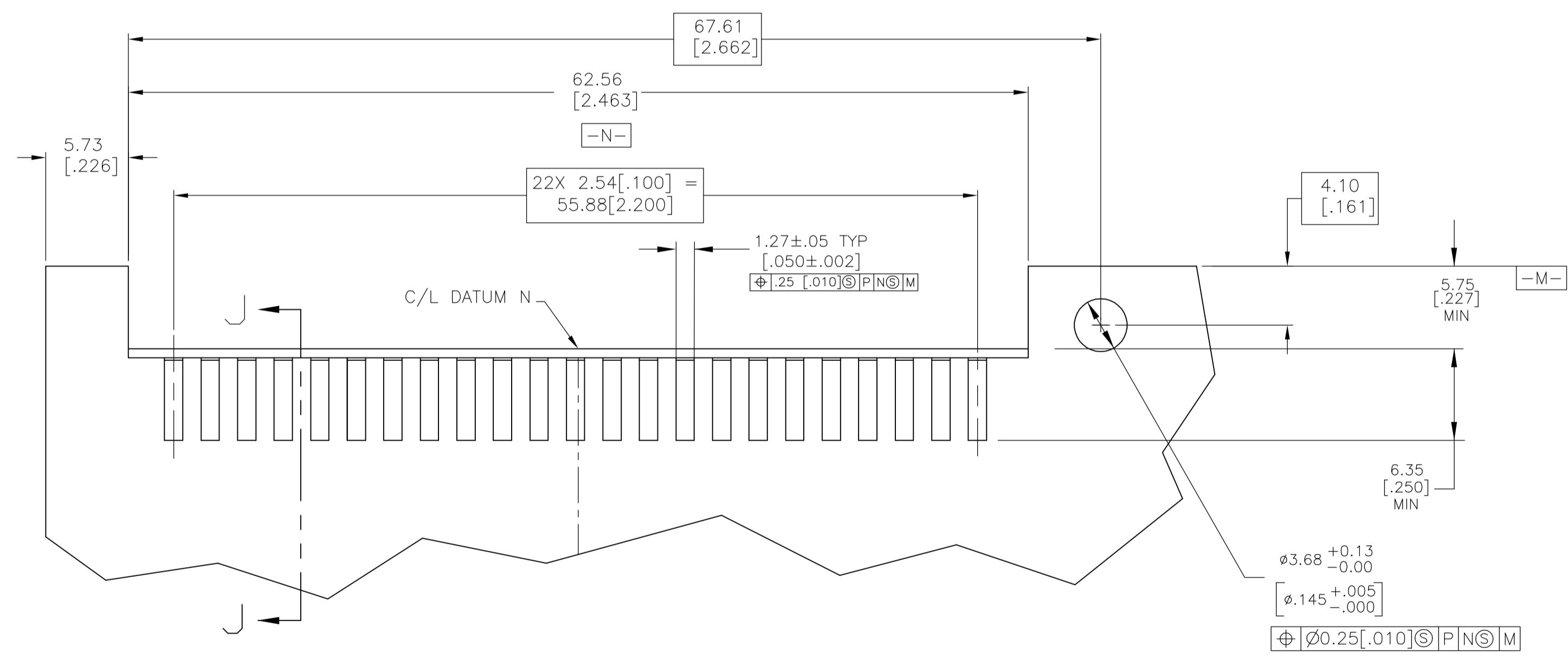

RECOMMENDED PC BOARD LAYOUT FOR CONNECTOR MOUNTING
 TYP BOTH SIDES

| | | | | |
|--|--|--|---|--|
| THIS DRAWING IS A CONTROLLED DOCUMENT. | | DN: AL FRANTUM / L.A. MAYER 22JUNE2006 | Tyco Electronics Corporation Harrisburg, PA 17105-3608 | |
| DIMENSIONS: MM | | CHK: AL FRANTUM 22JUNE2006 | NAME: AL FRANTUM | |
| TOLERANCES UNLESS OTHERWISE SPECIFIED: | | APVD: S. FLICKINGER 22JUNE2006 | PRODUCT SPEC: 108-2202 | |
| 0 PLC ± - | | APPLICATION SPEC: - | | |
| 1 PLC ± - | | SIZE: A1 | | |
| 2 PLC ± .26 [.010] | | CAGE CODE: 00779 | | |
| 3 PLC ± - | | DRAWING NO: 1888143 | | |
| 4 PLC ± - | | RESTRICTED TO: - | | |
| ANGLES ± 1° | | SCALE: 4:1 | | |
| FINISH: SEE SHEET 1 | | SHEET 2 OF 2 | | |
| MATERIAL: SEE SHEET 1 | | REV: - | | |
| | | CUSTOMER DRAWING | | |