

BASE CAGE DETAILS

1000173242

SHOWN

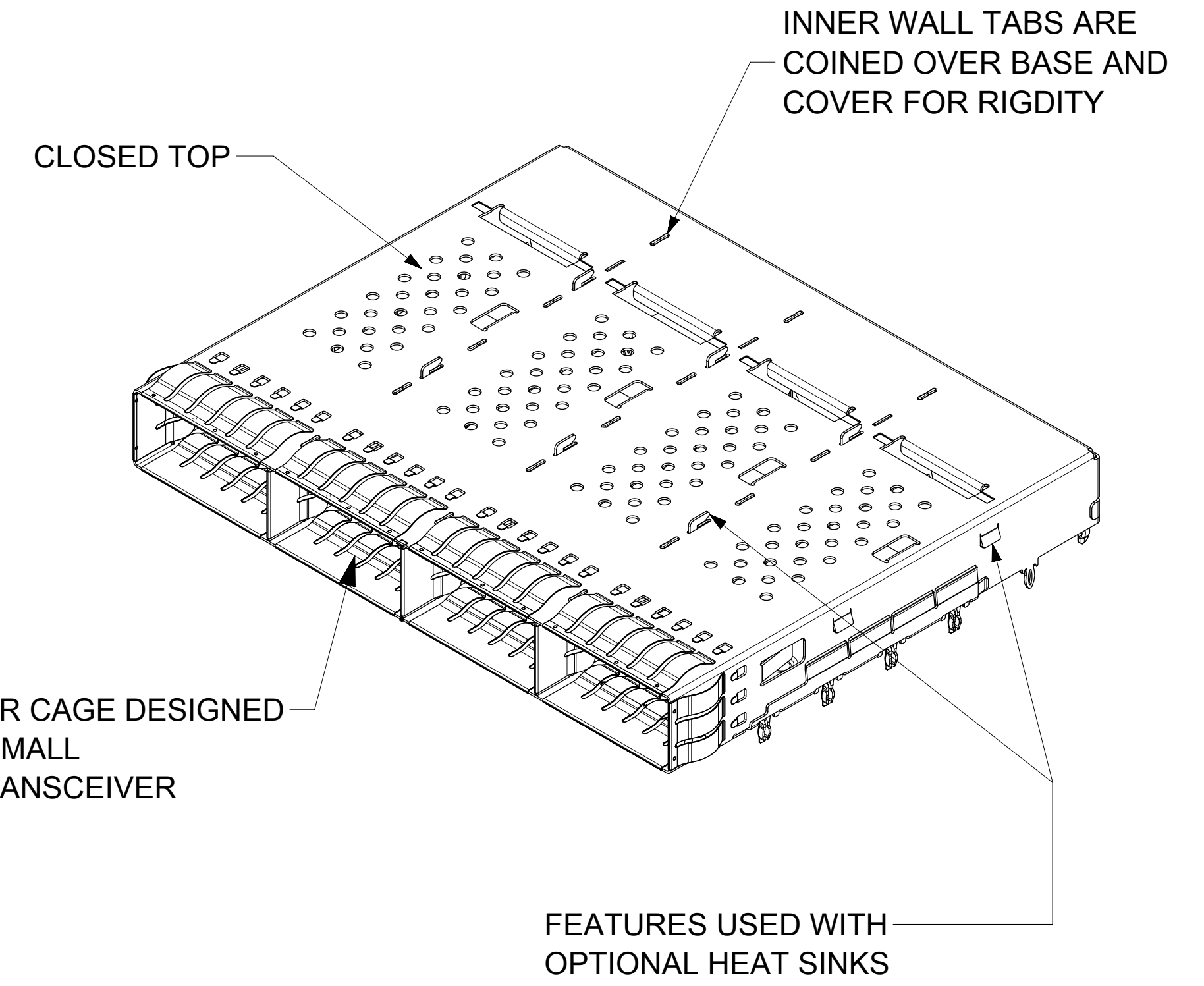
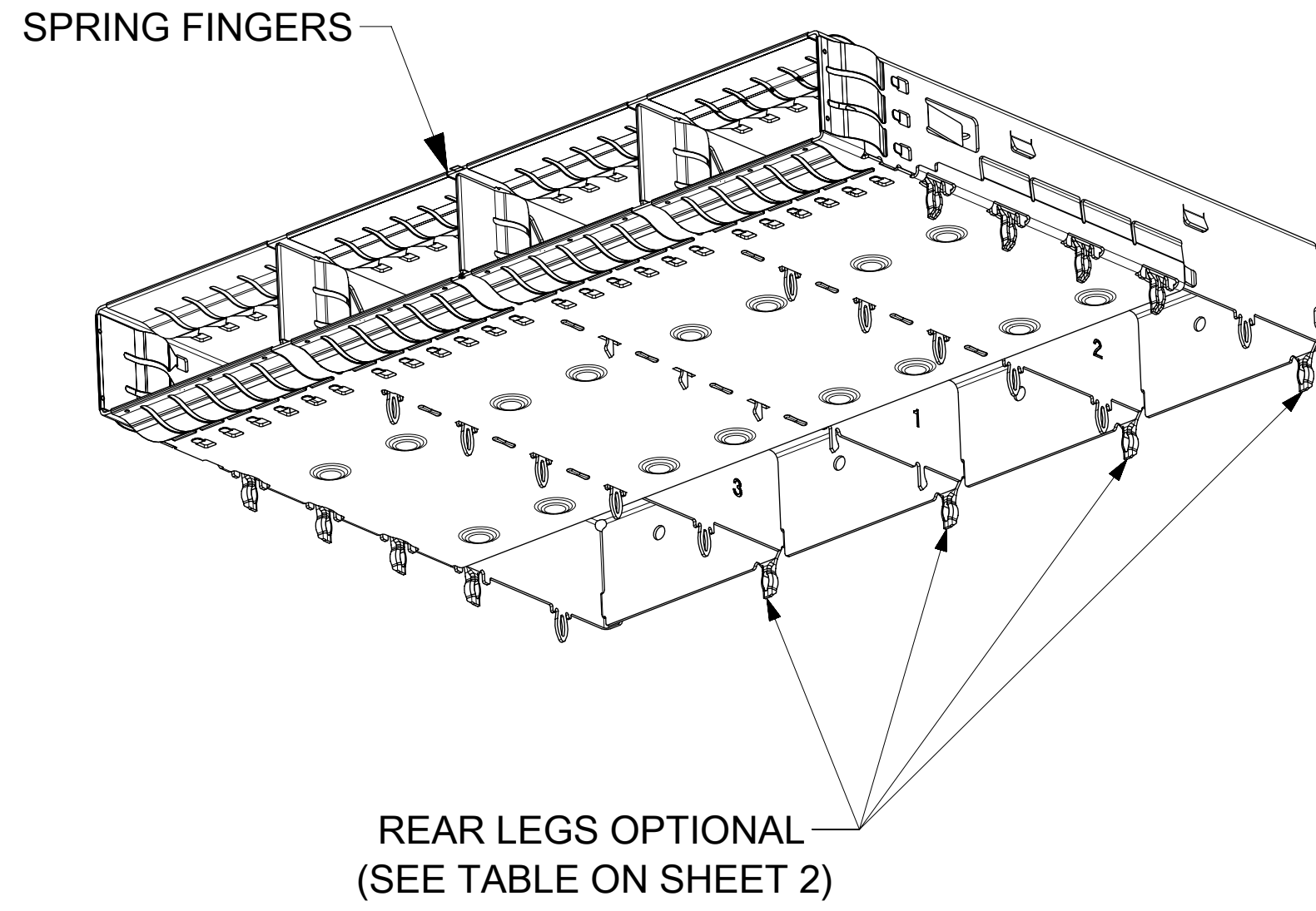
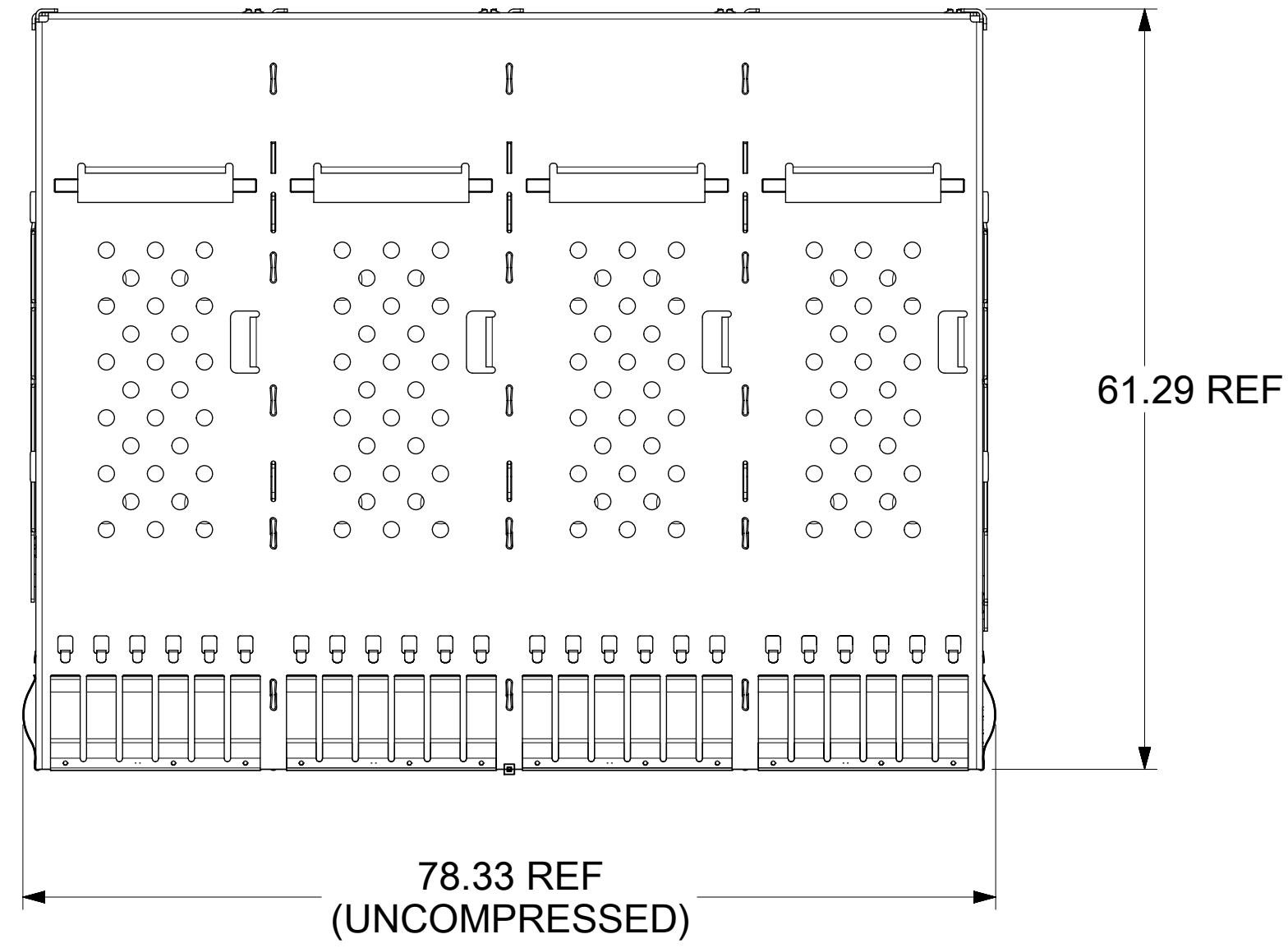

DIMENSIONS OF EACH INNER CAGE DESIGNED TO FUNCTION WITH QUAD SMALL FORM-FACTOR (zQSFP+) TRANSCEIVER

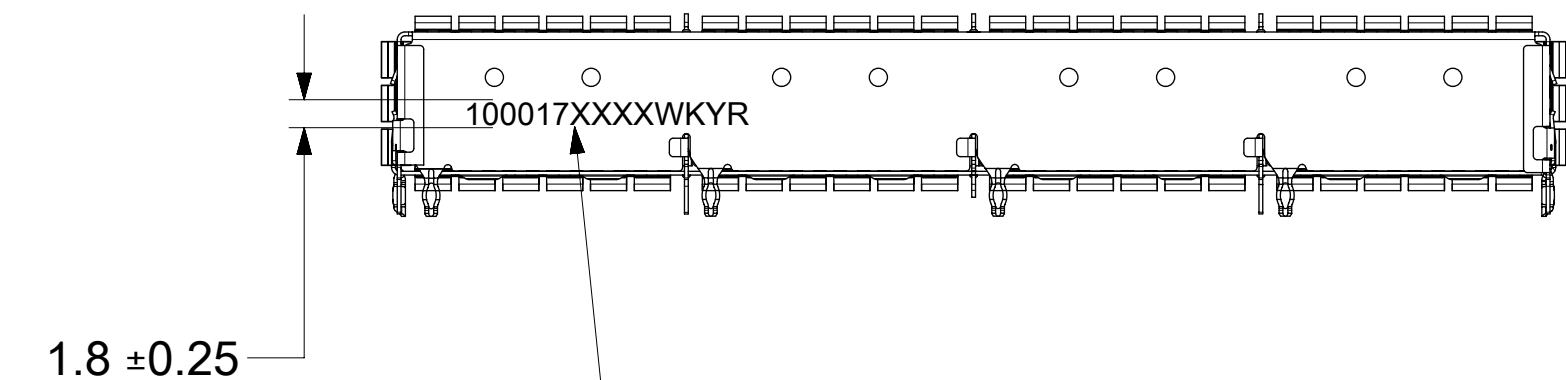
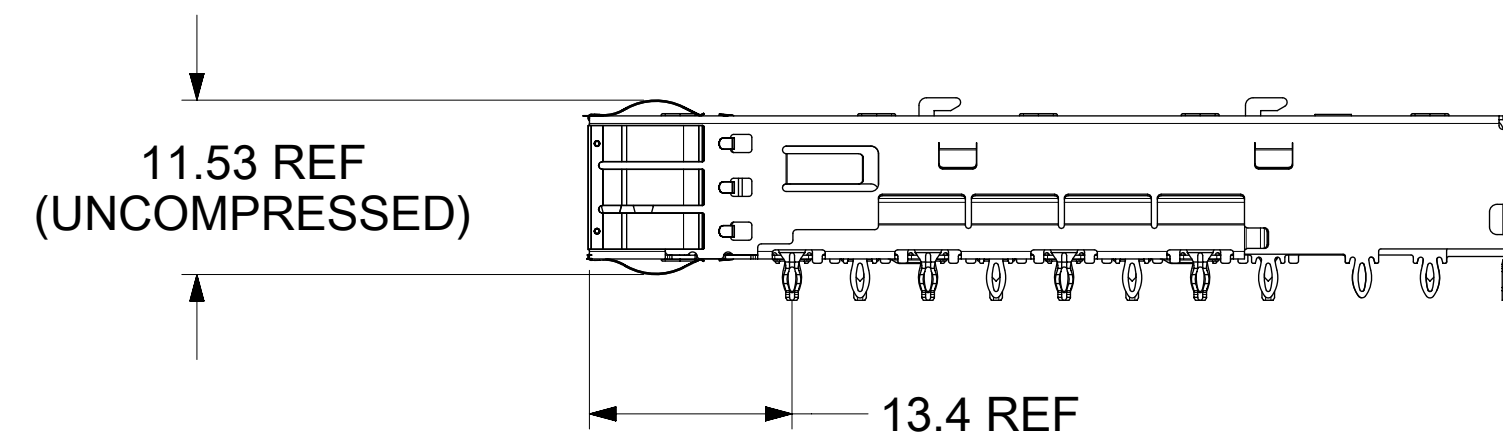
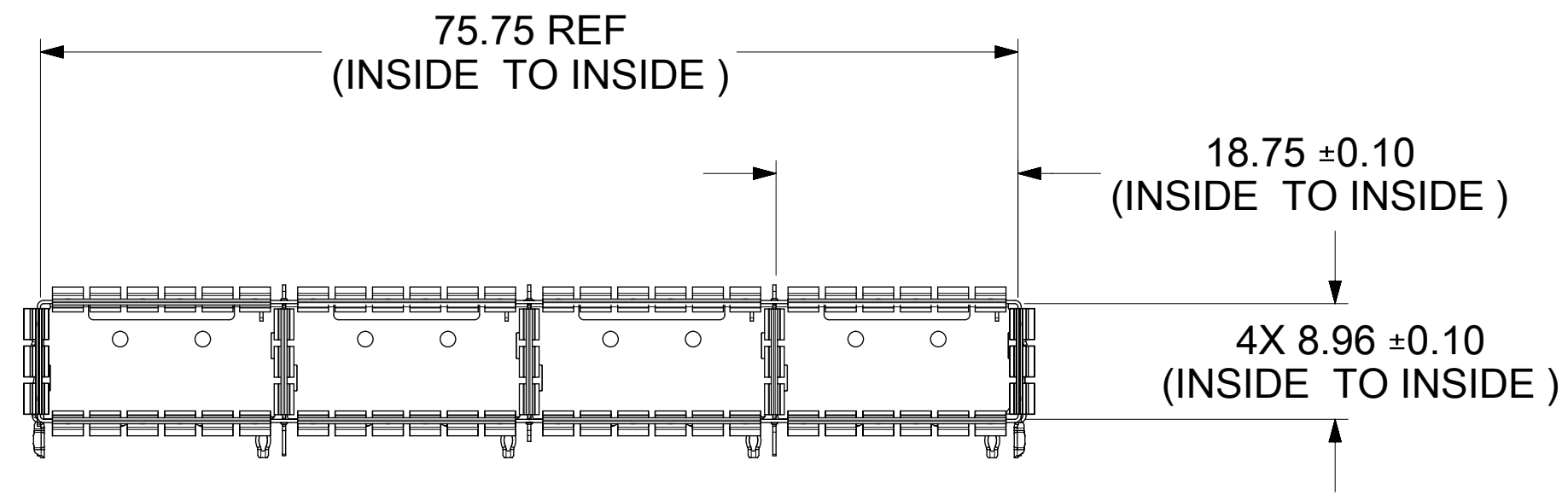

P/N AND WEEK/YEAR DATE CODE TO BE PRINTED ON BACK OF COMPLETED CAGE ASSEMBLY APPROXIMATELY AS SHOWN. SEE TABLE BELOW FOR DATE CODE INFORMATION.

- NOTES:
- MATERIAL: CAGE: STAINLESS STEEL
CENTER WALLS: STAINLESS STEEL
SPRING FINGERS: STAINLESS STEEL
HEAT SINKS: NICKEL PLATED ALUMINUM
HEAT SINK CLIP: STAINLESS STEEL
LIGHT PIPES: POLYCARBONATE (UL 94-V-0)
 - DIMENSIONS MARKED ∇ ARE CRITICAL TO FUNCTION OF THE PART AND MUST BE INSPECTED
 - DRAWING APPLIES TO ALL P/N'S SHOWN ON PAGE 3
 - DURING FINAL INSPECTION, CAGE LEG LOCATIONS AND STRAIGHTNESS MUST BE CHECKED USING APPROPRIATE GO - NO GO GAGE
 - DURING FINAL INSPECTION, CAGE MUST BE INSPECTED TO MAKE SURE LEG CONFIGURATIONS AND PART NUMBERS ARE CORRECT, USE SHEETS 3, 4 AND 5
 - PARTS TO BE INSPECTED PER MOLEX COSMETIC SPEC WI-HP-7-2774 (CLASS B UNLESS OTHERWISE SPECIFIED)
 - PRESS-FIT LEGS 2.44 LONG -
1.57 MINIMUM PCB THICKNESS FOR SINGLE SIDED USE.
3.00 MINIMUM PCB THICKNESS FOR BELLY TO BELLY USE.
 - NO RoHS EXEMPTIONS
 - WELD SPOTS MAY SHOW SLIGHT MATERIAL DISCOLORATION.

WEEK/YEAR DATE CODE TABLE										
WK	WEEK OF THE YEAR 01 THRU 52 (EXAMPLE: 01= FIRST WEEK OF YEAR 52= LAST WEEK OF YEAR)									
YR	22, 23, 24 ETC.. (EXAMPLE: YEAR 2022= 22)									
FUNCTIONAL SYMBOLS	THIS DRAWING CONTAINS INFORMATION THAT IS PROPRIETARY TO MOLEX ELECTRONIC TECHNOLOGIES, LLC AND SHOULD NOT BE USED WITHOUT WRITTEN PERMISSION									
$\nabla_A = 0$	DIMENSION UNITS	SCALE	CURRENT REV DESC: SEE REVISION TABLE							<p>ZQSFP+ 1X4 GANGED CAGE ASSY'S W/ SS TAB TYPE SPRING FINGER H/S & L/P OPTIONS</p> <p>PRODUCT CUSTOMER DRAWING</p>
$\nabla_C = 0$	mm	2:1	GENERAL TOLERANCES (UNLESS SPECIFIED)							
$\nabla_P = 0$	ANGULAR TOL $\pm 1.0^\circ$		EC NO: 698865							
DIVISIONAL SYMBOLS	4 PLACES	\pm	DRWN: KRISHH1 2022/02/17							
	3 PLACES	\pm	CHK'D: TKUMARKC 2022/03/10							
	2 PLACES	± 0.13	APPR: JCHIANG 2022/03/21							
	1 PLACE	± 0.25	INITIAL REVISION:							
	0 PLACES	\pm	DRWN: KRISHH1 2022/02/17							
	DRAFT WHERE APPLICABLE MUST REMAIN WITHIN DIMENSIONS		THIRD ANGLE PROJECTION		DRAWING	SERIES	MATERIAL NUMBER	CUSTOMER	SHEET NUMBER	
			D-SIZE		100017	SEE P/N TABLE	GENERAL MARKET	PSD ASY A	1 OF 8	

CAGE ASSEMBLY OPTIONS

1000173544

SHOWN

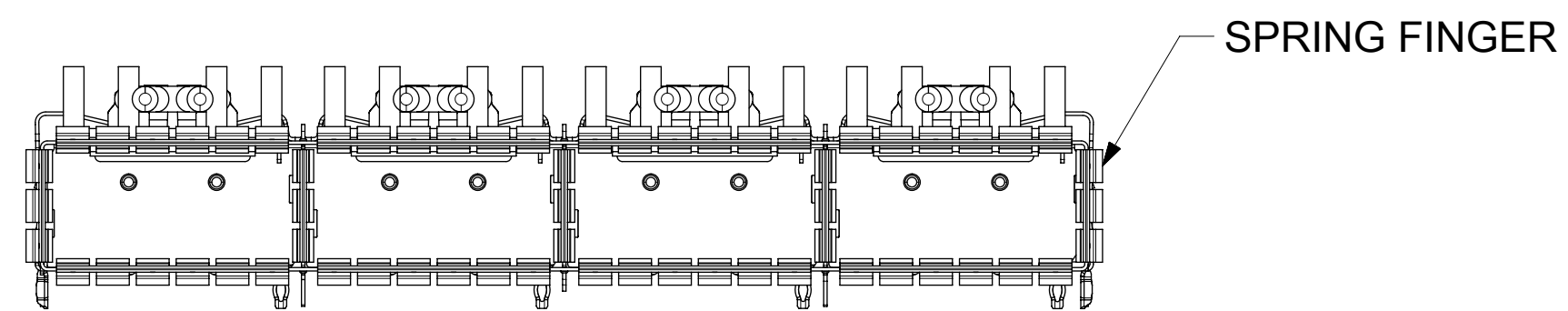
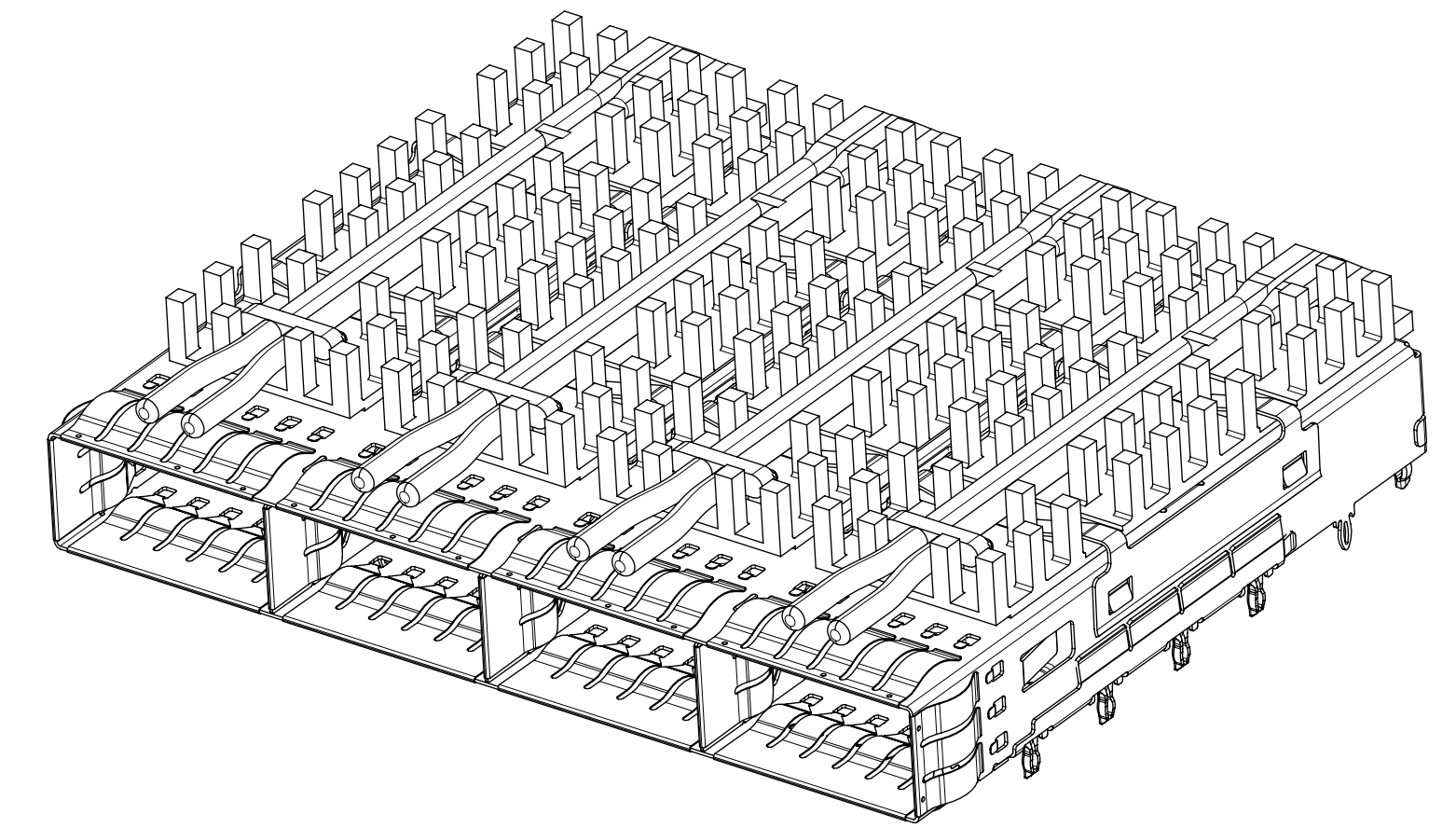
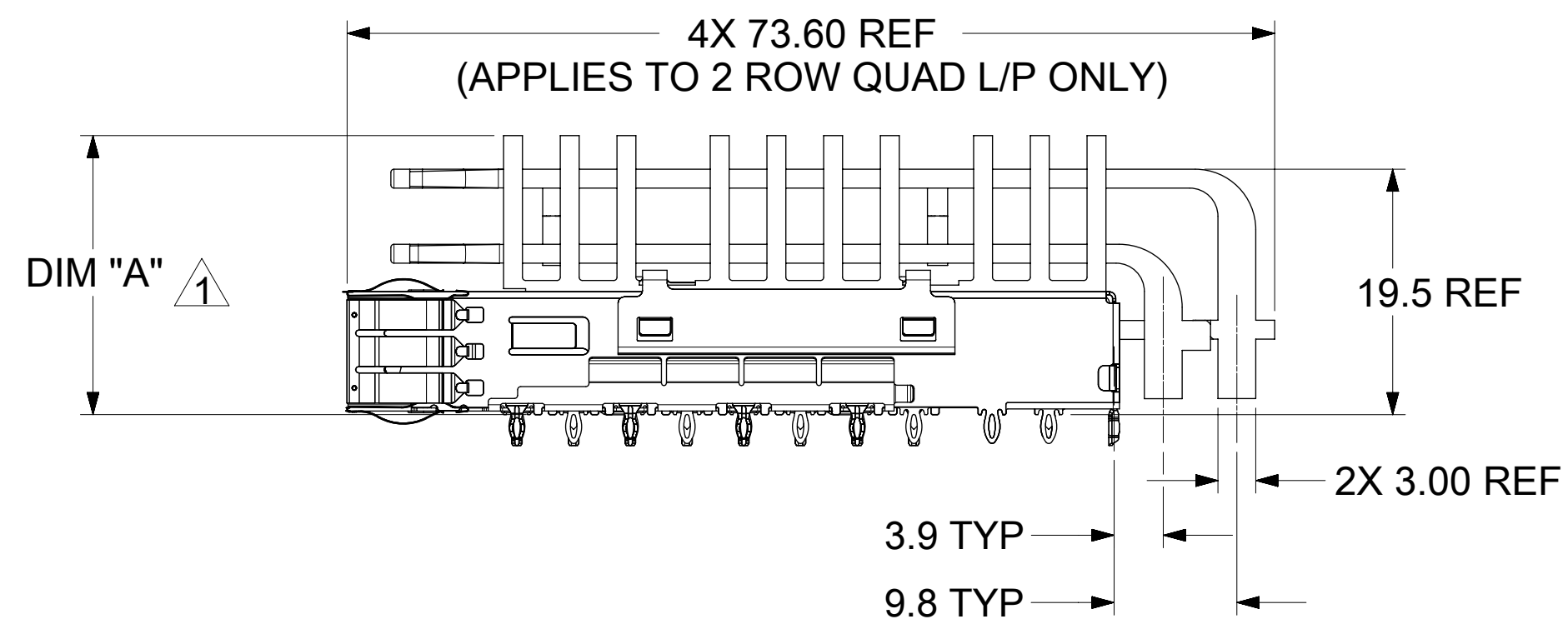
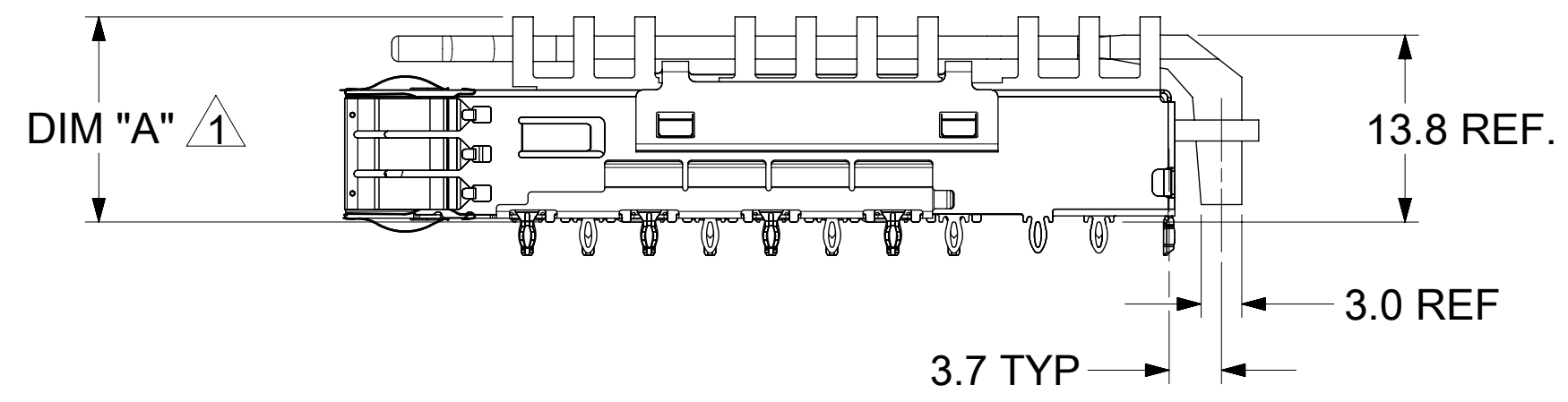
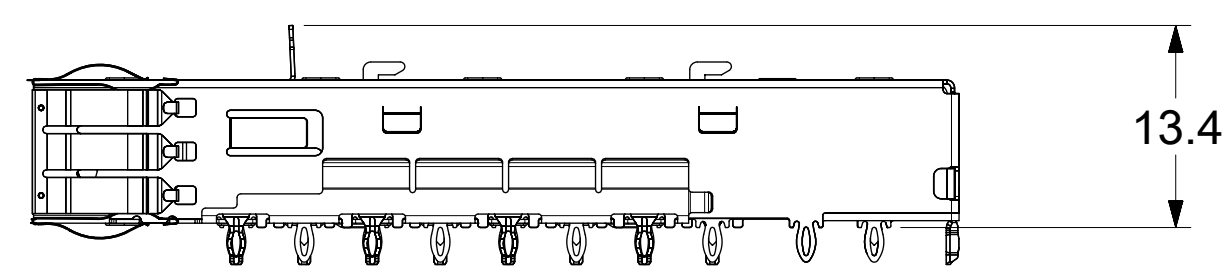
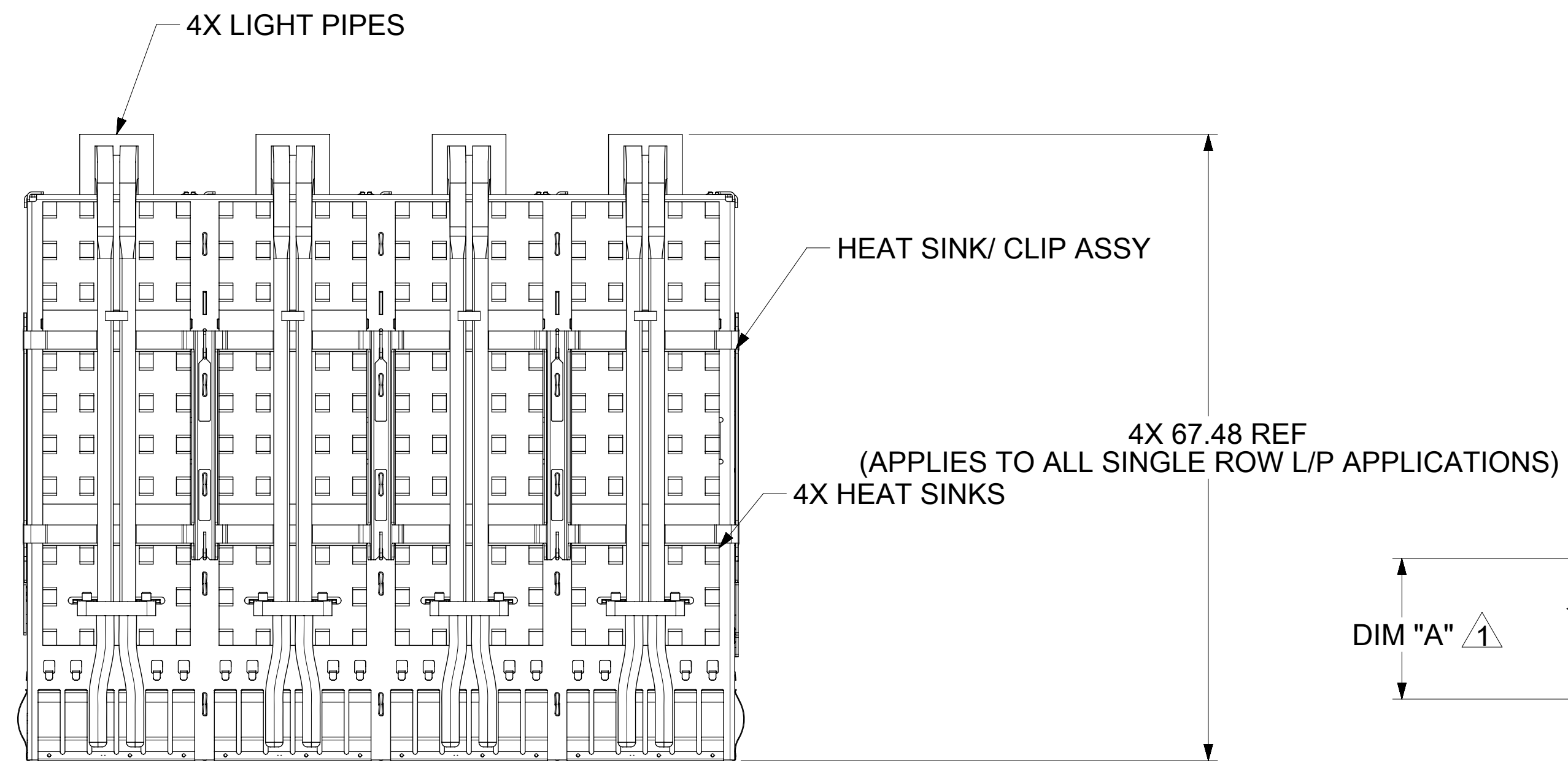

OVERALL HEAT SINK HEIGHT	DIM "A"
PCI	13.7 REF
SAN	16.0 REF
NET	23.0 REF

\triangle HEIGHT OF HEAT SINK WITH MODULE INSERTED.
DIMENSION MAY BE LESS DUE TO MODULE AND HEAT SINK VARIATIONS

HEATSINK AND LIGHT PIPE COMBINATIONS

HEATSINK
USED
WITHOUT
LIGHTPIPE

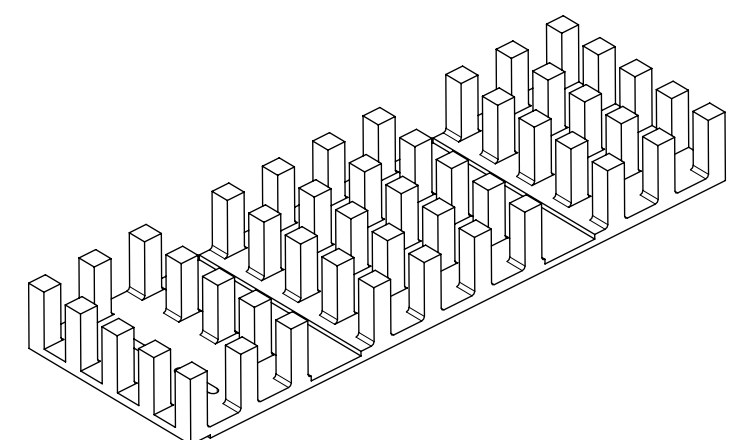

SINGLE / DUAL LIGHT PIPE

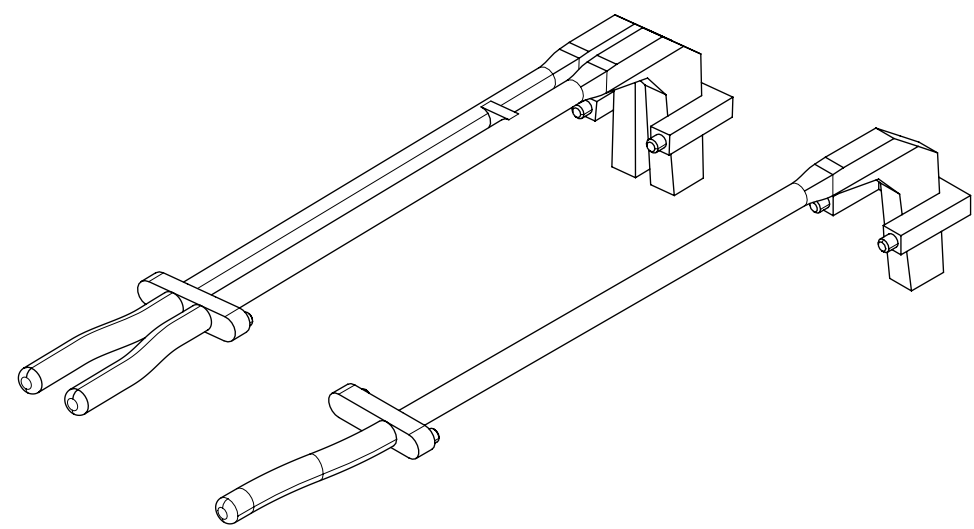

HEATSINK

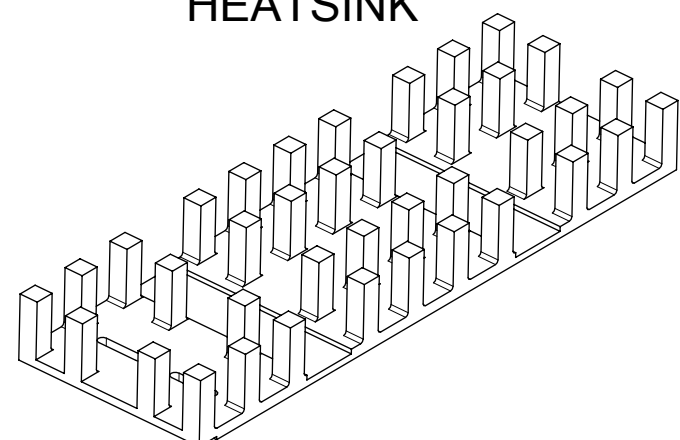

QUAD LIGHT PIPE

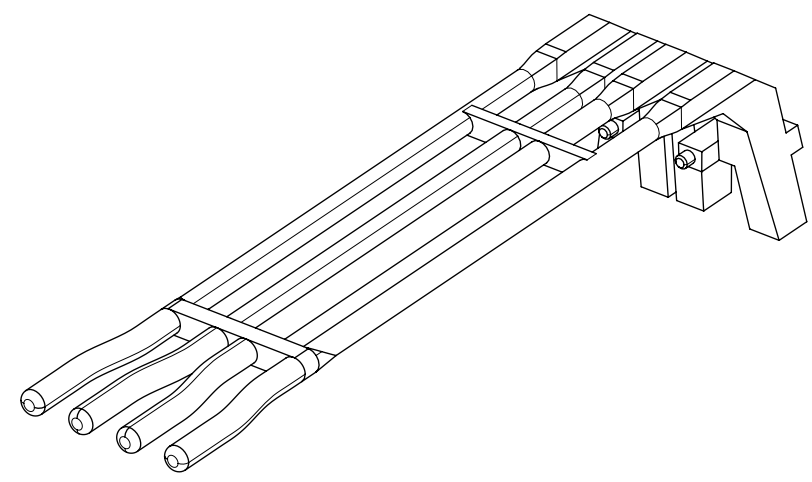

HEATSINK

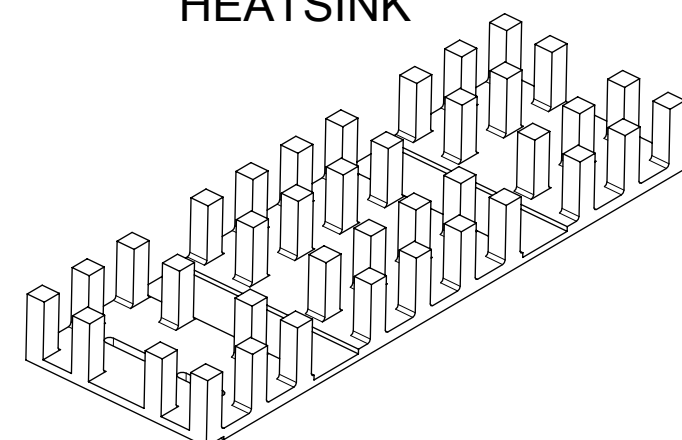

2 ROW QUAD LIGHT PIPE

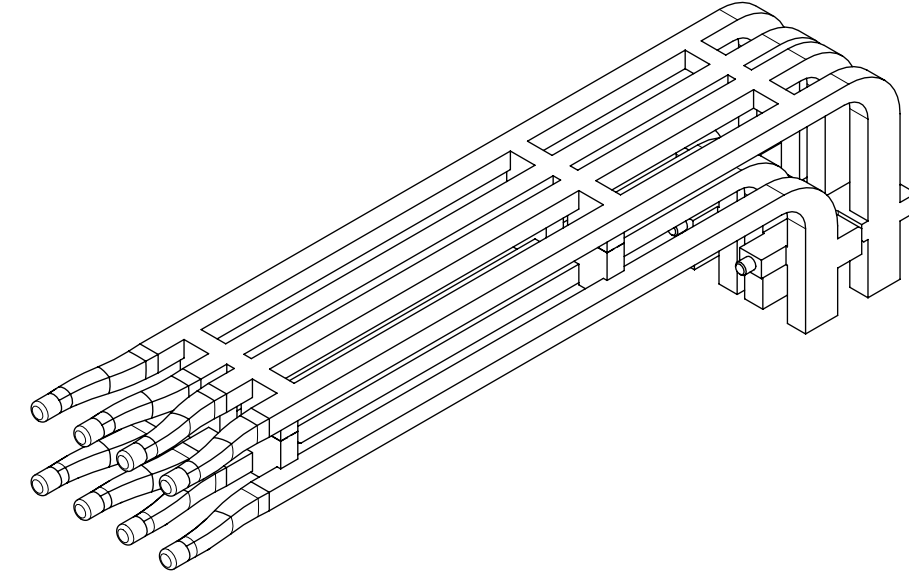

HEATSINK

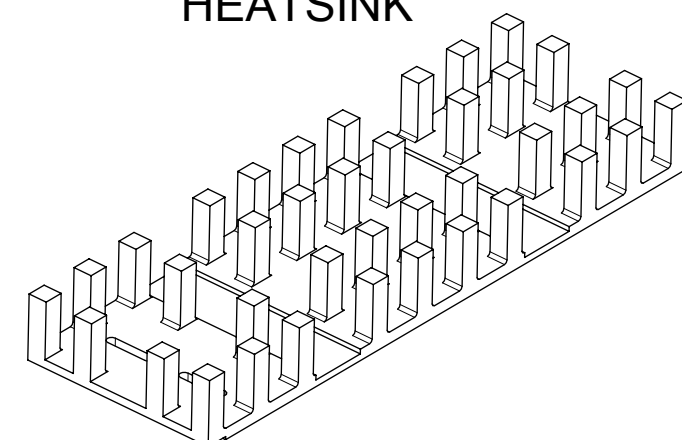

REAR LEG OPTIONS

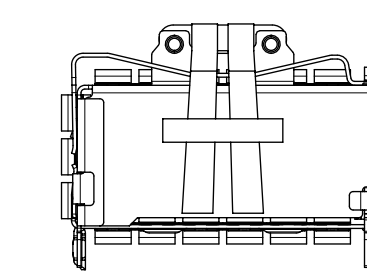

0 REAR LEGS

Partial1
Scale 2.5:1

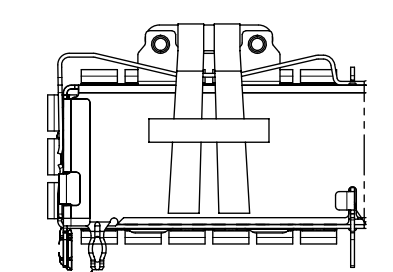

1 REAR LEGS

Partial2
Scale 2.5:1

THIS DRAWING CONTAINS INFORMATION THAT IS PROPRIETARY TO MOLEX ELECTRONIC TECHNOLOGIES, LLC AND SHOULD NOT BE USED WITHOUT WRITTEN PERMISSION

DIMENSION UNITS	SCALE	CURRENT REV DESC: SEE REVISION TABLE	
mm	2:1		
GENERAL TOLERANCES (UNLESS SPECIFIED)			
ANGULAR TOL \pm 1.0°			
4 PLACES	\pm	EC NO: 698865	
3 PLACES	\pm	DRWN: KRISHH1	2022/02/17
2 PLACES	\pm 0.13	CHK'D: TKUMARKC	2022/03/10
1 PLACE	\pm 0.25	APPR: JCHIANG	2022/03/21
0 PLACES	\pm	INITIAL REVISION:	
DRAFT WHERE APPLICABLE MUST REMAIN WITHIN DIMENSIONS		DRWN: KRISHH1	2022/02/17
THIRD ANGLE PROJECTION		APPR: JCHIANG	2022/03/21
DRAWING		SERIES	MATERIAL NUMBER
D-SIZE		100017	SEE P/N TABLE
CUSTOMER		GENERAL MARKET	
SHEET NUMBER		2 OF 8	

molex

ZQSFP+ 1X4 GANGED CAGE ASSY'S
W/ SS TAB TYPE SPRING FINGER H/S & L/P
OPTIONS

PRODUCT CUSTOMER DRAWING

DOCUMENT NUMBER DOC TYPE DOC PART REVISION

1000173200

PSD ASY A

PART NUMBER SELECTION

NO HEATSINKS
NO LIGHT PIPES
CLOSED TOP

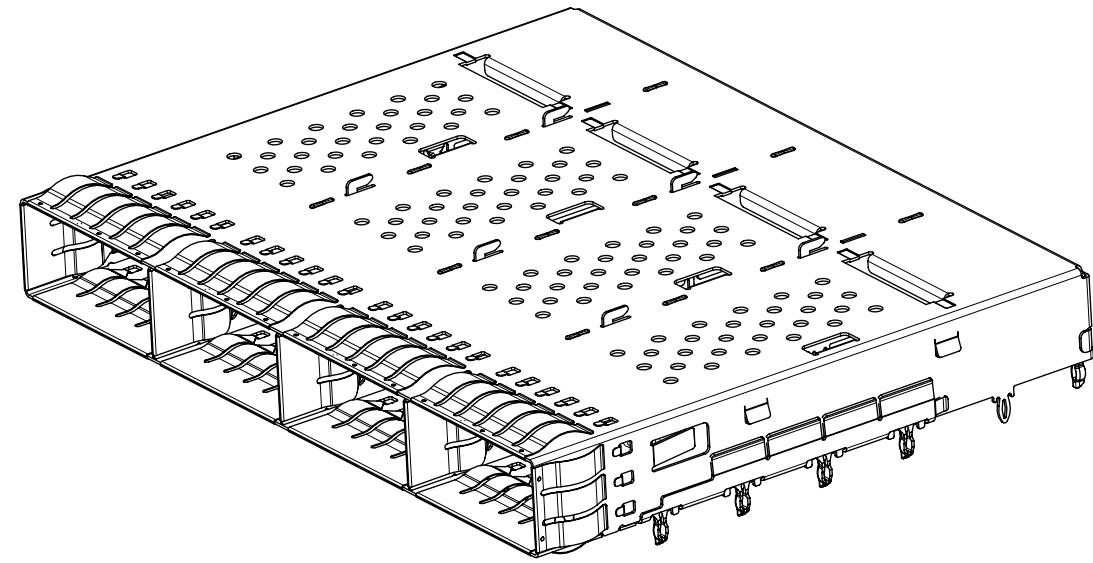

MOLEX P/N W/ SPRING FINGERS	#OF REAR LEGS PER PORT
1000173242	1

NO HEATSINKS
NO LIGHT PIPES
OPEN TOP

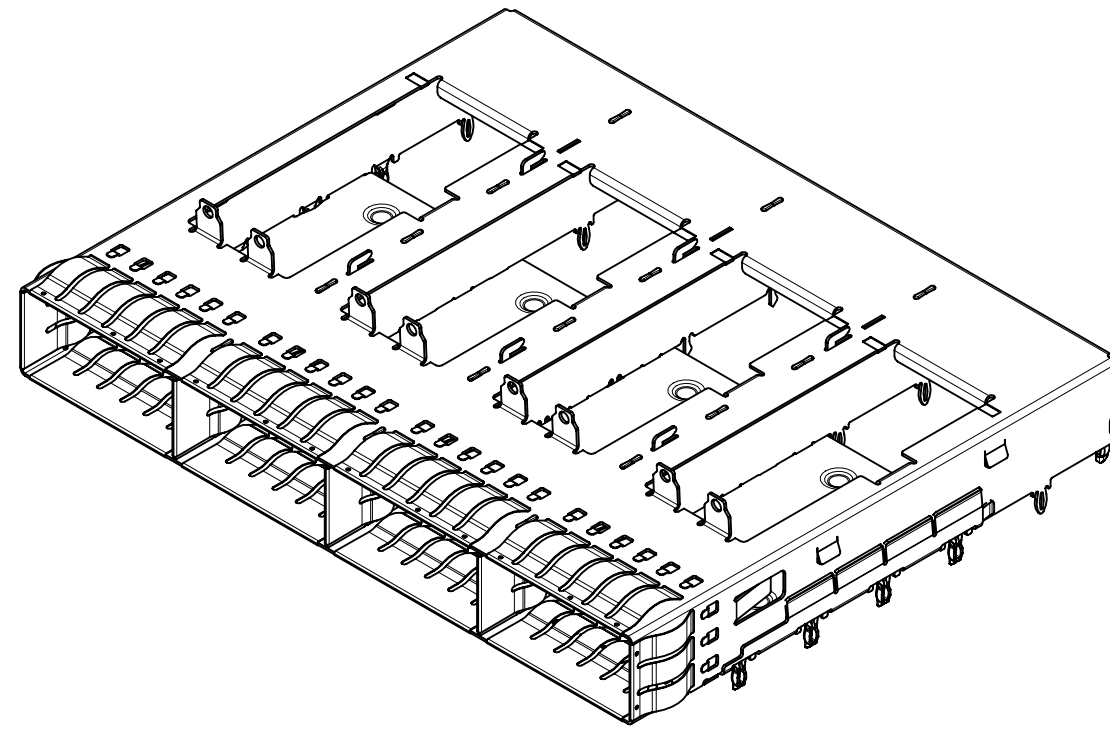

MOLEX P/N W/ SPRING FINGERS	#OF REAR LEGS PER PORT
1000173252	1

WITH HEATSINKS
NO LIGHT PIPES

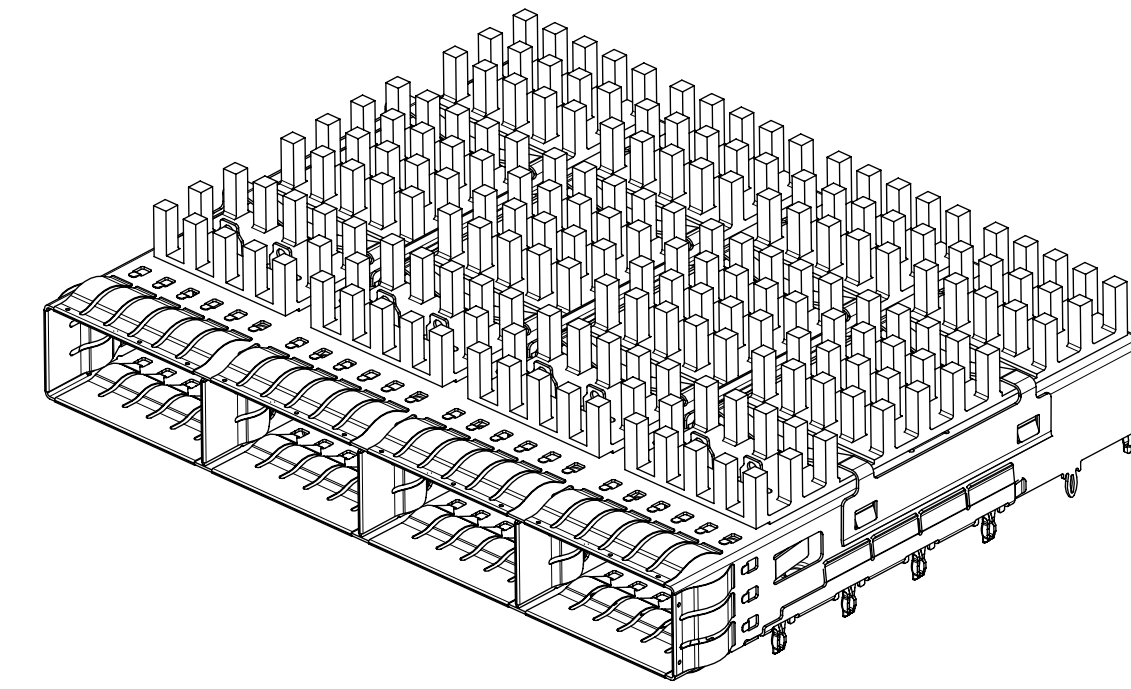

MOLEX P/N	HEATSINKS	#OF REAR LEGS PER PORT
1000173343	PCI	1
1000173344	SAN	1

WITH HEATSINKS AND LIGHT PIPES

MOLEX P/N	LIGHTPIPES	HEATSINKS	#OF REAR LEGS PER PORT
1000173443	DUAL	PCI	0
1000173446	QUAD	PCI	0
1000173542	SINGLE	NET	1
1000173544	DUAL	SAN	1
1000173547	QUAD	SAN	1
1000173548	QUAD	NET	1

SINGLE LIGHT PIPE

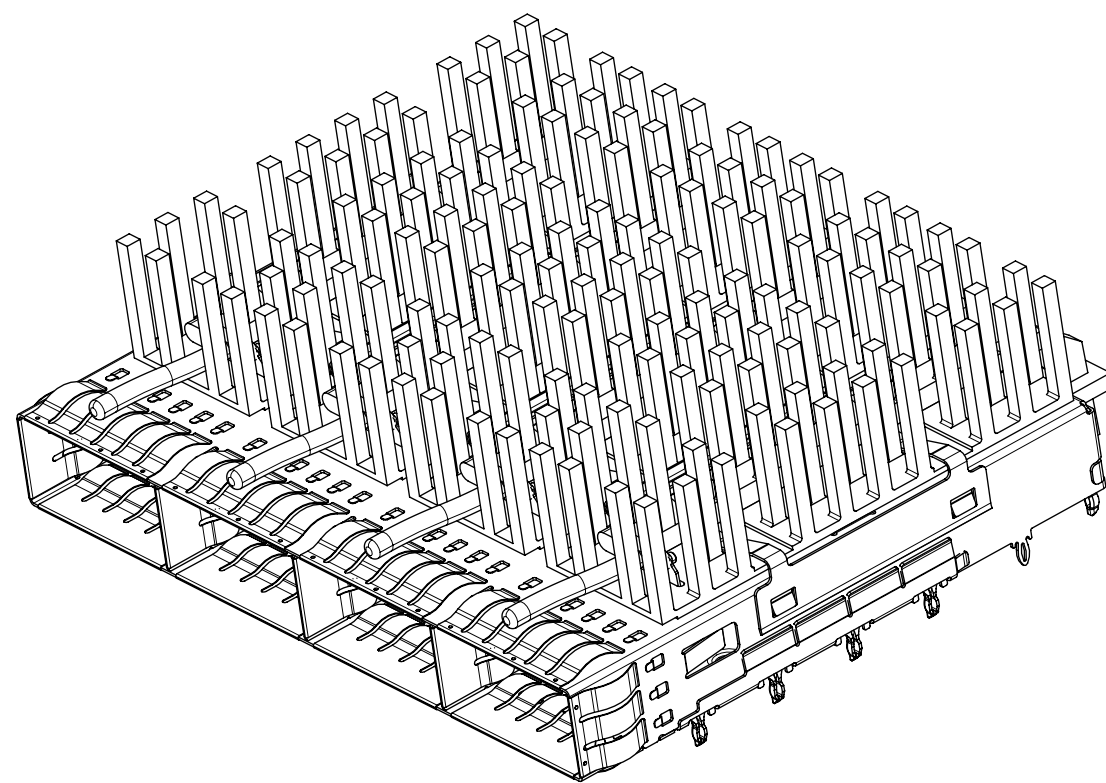

DUAL LIGHT PIPE

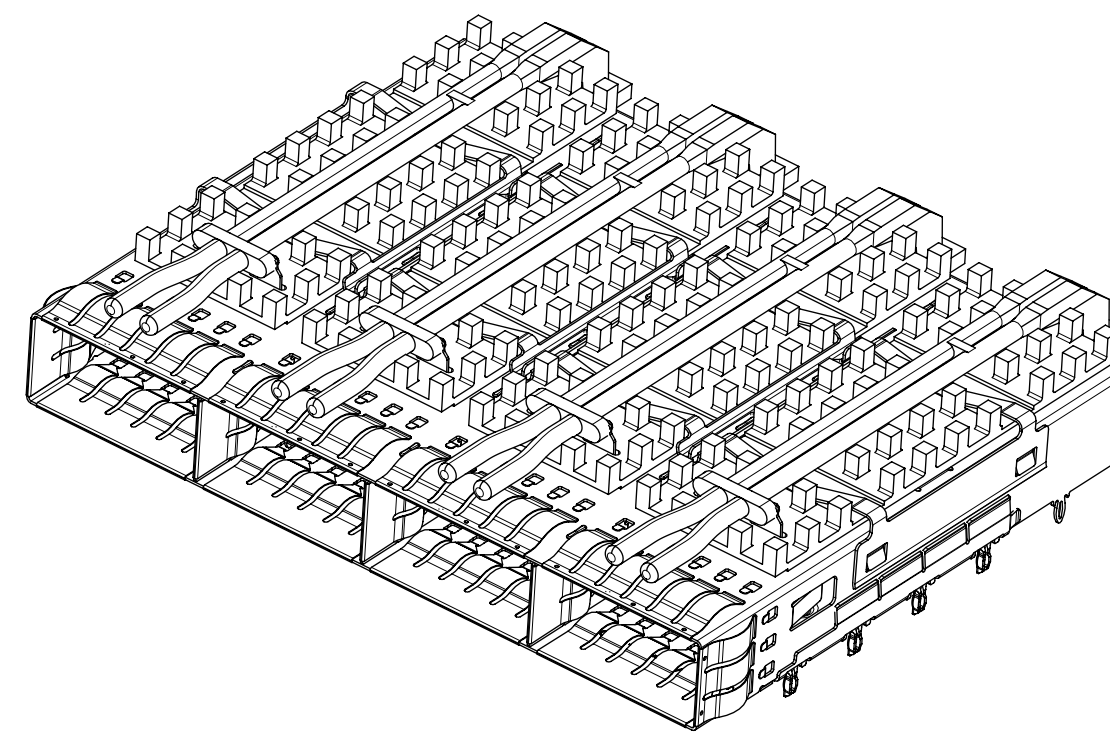

QUAD LIGHT PIPE

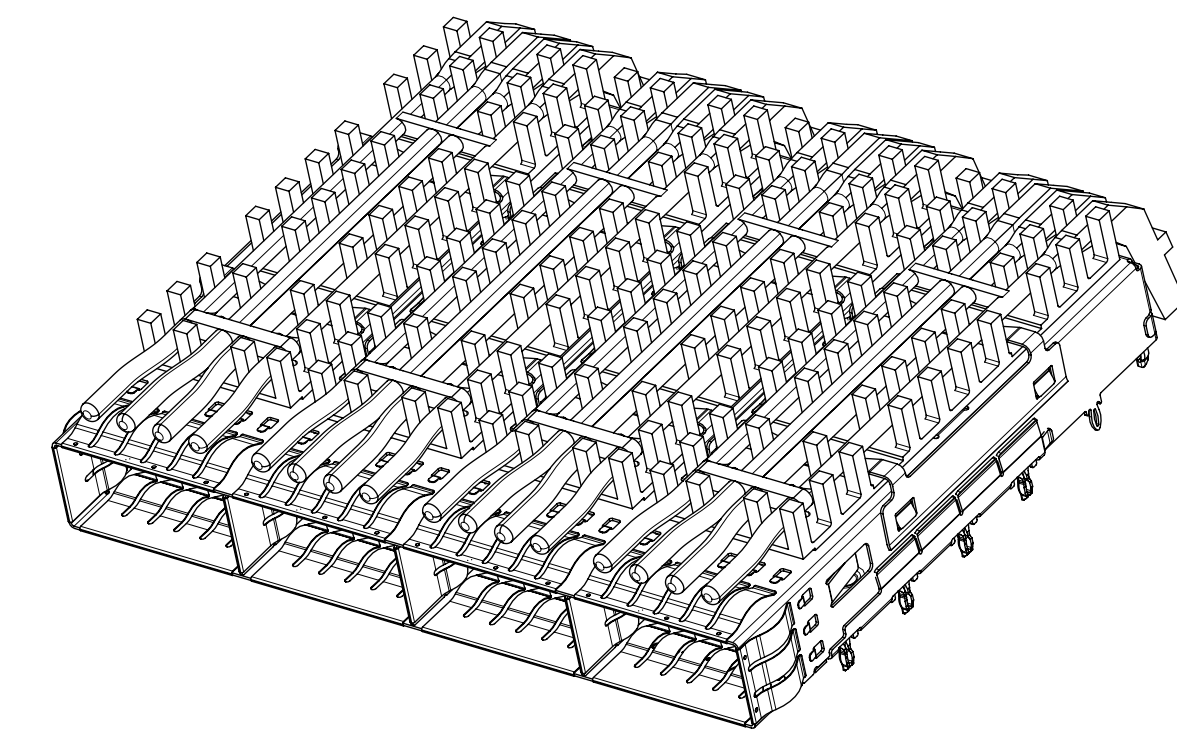

THIS DRAWING CONTAINS INFORMATION THAT IS PROPRIETARY TO MOLEX ELECTRONIC TECHNOLOGIES, LLC AND SHOULD NOT BE USED WITHOUT WRITTEN PERMISSION

DIMENSION UNITS: **mm**
SCALE: **1.5:1**

GENERAL TOLERANCES
(UNLESS SPECIFIED)

ANGULAR TOL	± 1.0°
4 PLACES	±
3 PLACES	±
2 PLACES	± 0.13
1 PLACE	± 0.25
0 PLACES	±

CURRENT REV DESC: SEE REVISION TABLE

EC NO: 698865
DRWN: KRISHH1 2022/02/17
CHK'D: TKUMARKC 2022/03/10
APPR: JCHIANG 2022/03/21
INITIAL REVISION:
DRWN: KRISHH1 2022/02/17
APPR: JCHIANG 2022/03/21

molex

ZQSFP+ 1X4 GANGED CAGE ASSYS
W/ SS TAB TYPE SPRING FINGER H/S & L/P
OPTIONS

PRODUCT CUSTOMER DRAWING

DOCUMENT NUMBER	DOC TYPE	DOC PART	REVISION
1000173200	PSD	ASY	A

DRAFT WHERE APPLICABLE MUST REMAIN WITHIN DIMENSIONS	THIRD ANGLE PROJECTION	DRAWING	SERIES	MATERIAL NUMBER	CUSTOMER	SHEET NUMBER
		D-SIZE	100017	SEE P/N TABLE	GENERAL MARKET	3 OF 8

PCB LAYOUT FOR SINGLE SIDED MOUNTING

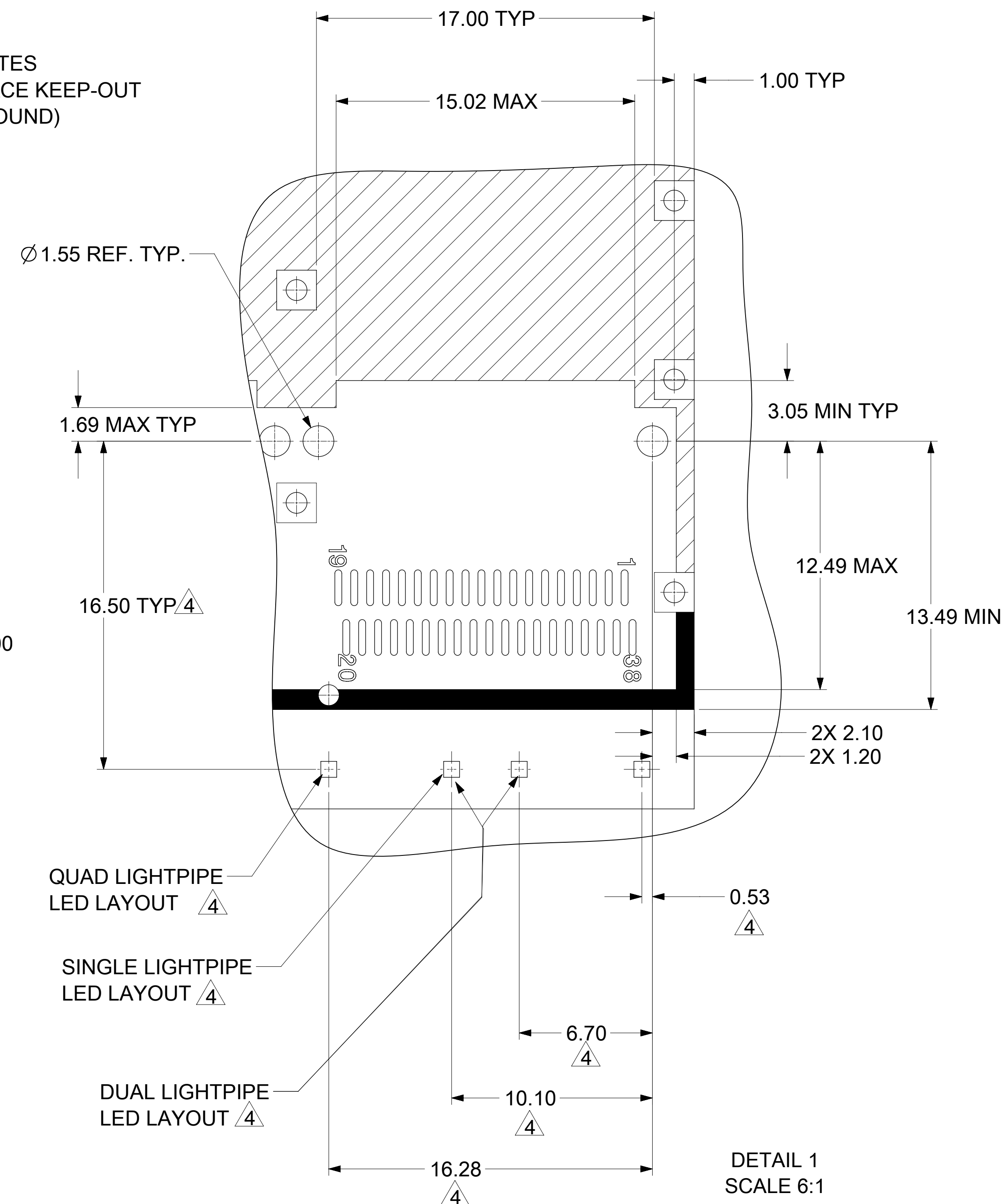
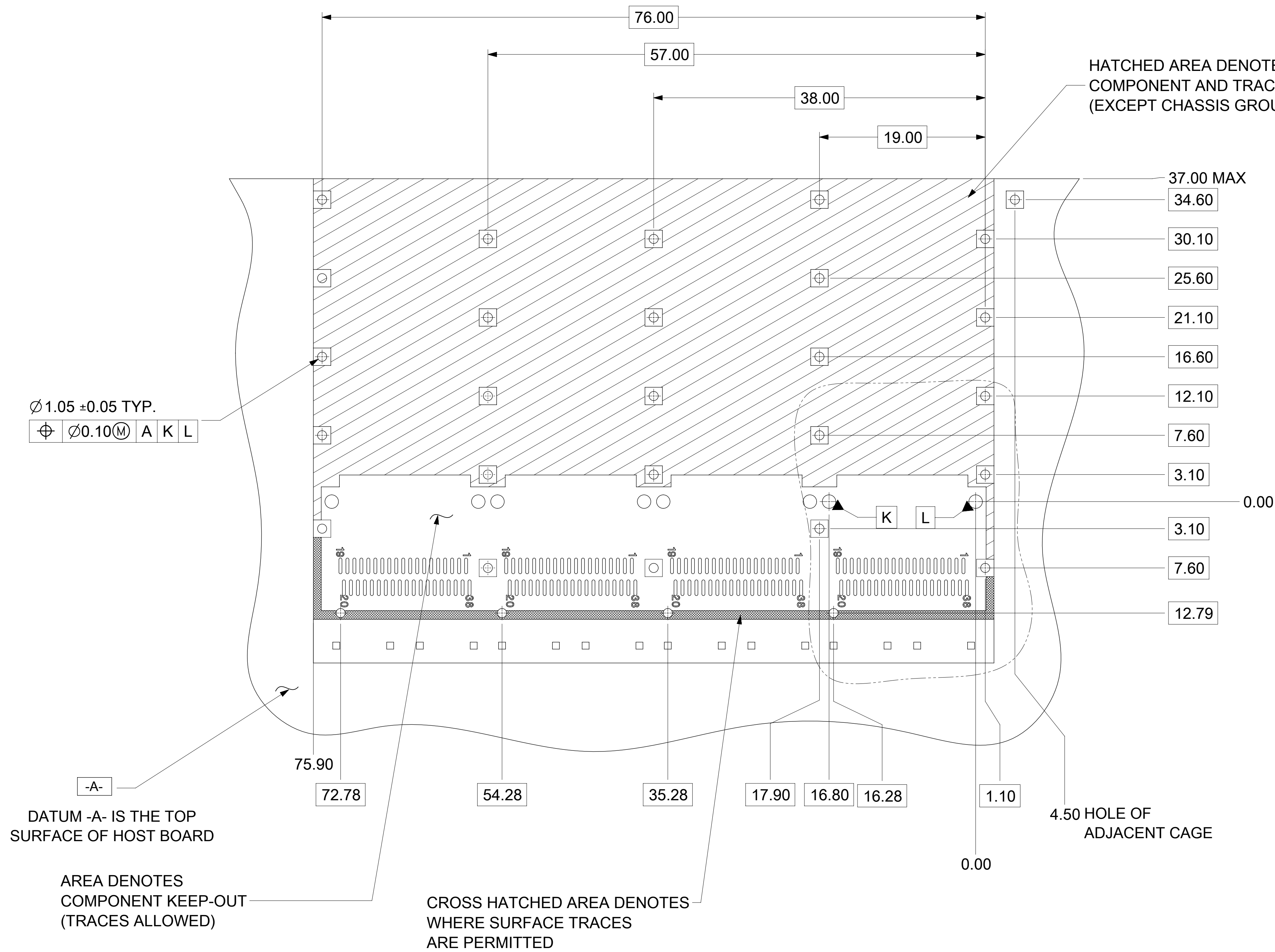

- NOTES:
1. PADS AND VIAS GO TO CHASSIS GROUND. (RECOMMENDED PADS TO BE 2.00mm SQUARE.)
 2. RECOMMENDED THRU HOLE PLATING INCLUDES HASL, OSP, OR IMMERSION (GOLD, SILVER, OR TIN).
 3. CONNECTOR PAD LAYOUT PER SFF-8663 WILL ACCOMODATE MOLEX CONNECTOR SERIES 170432.
 4. NOTED DIMENSIONS ONLY APPLY TO CAGE ASSEMBLIES WITH LIGHT PIPES.

THIS DRAWING CONTAINS INFORMATION THAT IS PROPRIETARY TO MOLEX ELECTRONIC TECHNOLOGIES, LLC AND SHOULD NOT BE USED WITHOUT WRITTEN PERMISSION										
DIMENSION UNITS		SCALE		CURRENT REV DESC: SEE REVISION TABLE						
mm		3.5:1								
GENERAL TOLERANCES (UNLESS SPECIFIED)										
ANGULAR TOL ± 1.0°				EC NO: 698865						
4 PLACES ±				DRWN: KRISHH1		2022/02/17				
3 PLACES ±				CHK'D: TKUMARKC		2022/03/10				
2 PLACES ± 0.13				APPR: JCHIANG		2022/03/21				
1 PLACE ± 0.25				INITIAL REVISION:						
0 PLACES ±				DRWN: KRISHH1		2022/02/17				
				APPR: JCHIANG		2022/03/21				
DRAFT WHERE APPLICABLE MUST REMAIN WITHIN DIMENSIONS			THIRD ANGLE PROJECTION		DRAWING		SERIES		MATERIAL NUMBER	
			D-SIZE		100017		SEE P/N TABLE		CUSTOMER	
							GENERAL MARKET		SHEET NUMBER	
							4 OF 8			

PCB LAYOUT FOR BELLY TO BELLY MOUNTING

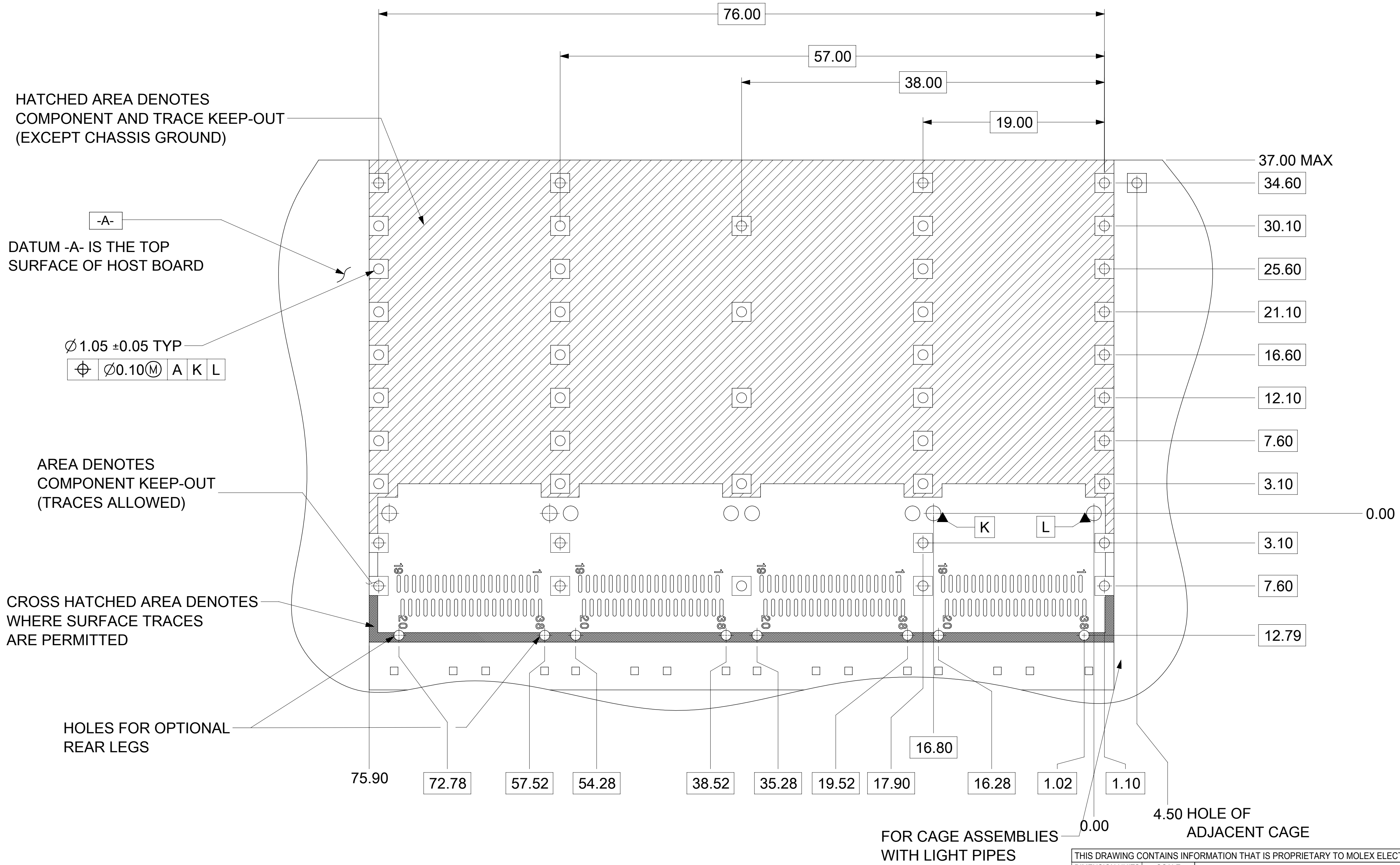

NOTE:
SEE SHEET 4 FOR HOST
CONNECTOR DETAIL
AND SINGLE ROW LED
LOCATION DETAIL

SEE SHEET 6 FOR DUAL-QUAD
LED LOCATION DETAIL

- NOTES:
1. PADS AND VIAS GO TO CHASSIS GROUND. (RECOMMENDED PADS TO BE 2.00mm SQUARE.)
 2. RECOMMENDED THRU HOLE PLATING INCLUDES HASL, OSP, OR IMMERSION (GOLD, SILVER, OR TIN).
 3. CONNECTOR PAD LAYOUT PER SFF-8663 WILL ACCOMODATE MOLEX CONNECTOR SERRIES 170432.

THIS DRAWING CONTAINS INFORMATION THAT IS PROPRIETARY TO MOLEX ELECTRONIC TECHNOLOGIES, LLC AND SHOULD NOT BE USED WITHOUT WRITTEN PERMISSION											
DIMENSION UNITS		SCALE		CURRENT REV DESC: SEE REVISION TABLE							
mm		4:1									
GENERAL TOLERANCES (UNLESS SPECIFIED)											
ANGULAR TOL ± 1.0°											
4 PLACES ±				EC NO: 698865				2022/02/17			
3 PLACES ±				DRWN: KRISHH1				2022/03/10			
2 PLACES ± 0.13				CHK'D: TKUMARKC				2022/03/21			
1 PLACE ± 0.25				APPR: JCHIANG							
0 PLACES ±				INITIAL REVISION:							
				DRWN: KRISHH1				2022/02/17			
				APPR: JCHIANG				2022/03/21			
DRAFT WHERE APPLICABLE MUST REMAIN WITHIN DIMENSIONS		THIRD ANGLE PROJECTION		DRAWING		SERIES		MATERIAL NUMBER		CUSTOMER	
				D-SIZE		100017		SEE P/N TABLE		GENERAL MARKET	
				DOCUMENT NUMBER		DOC TYPE		DOC PART		REVISION	
				1000173200		PSD		ASY		A	
				SHEET NUMBER		5 OF 8					

BEZEL AND BOARD POSITION DIMENSIONS
FOR BELLY TO BELLY MOUNTING

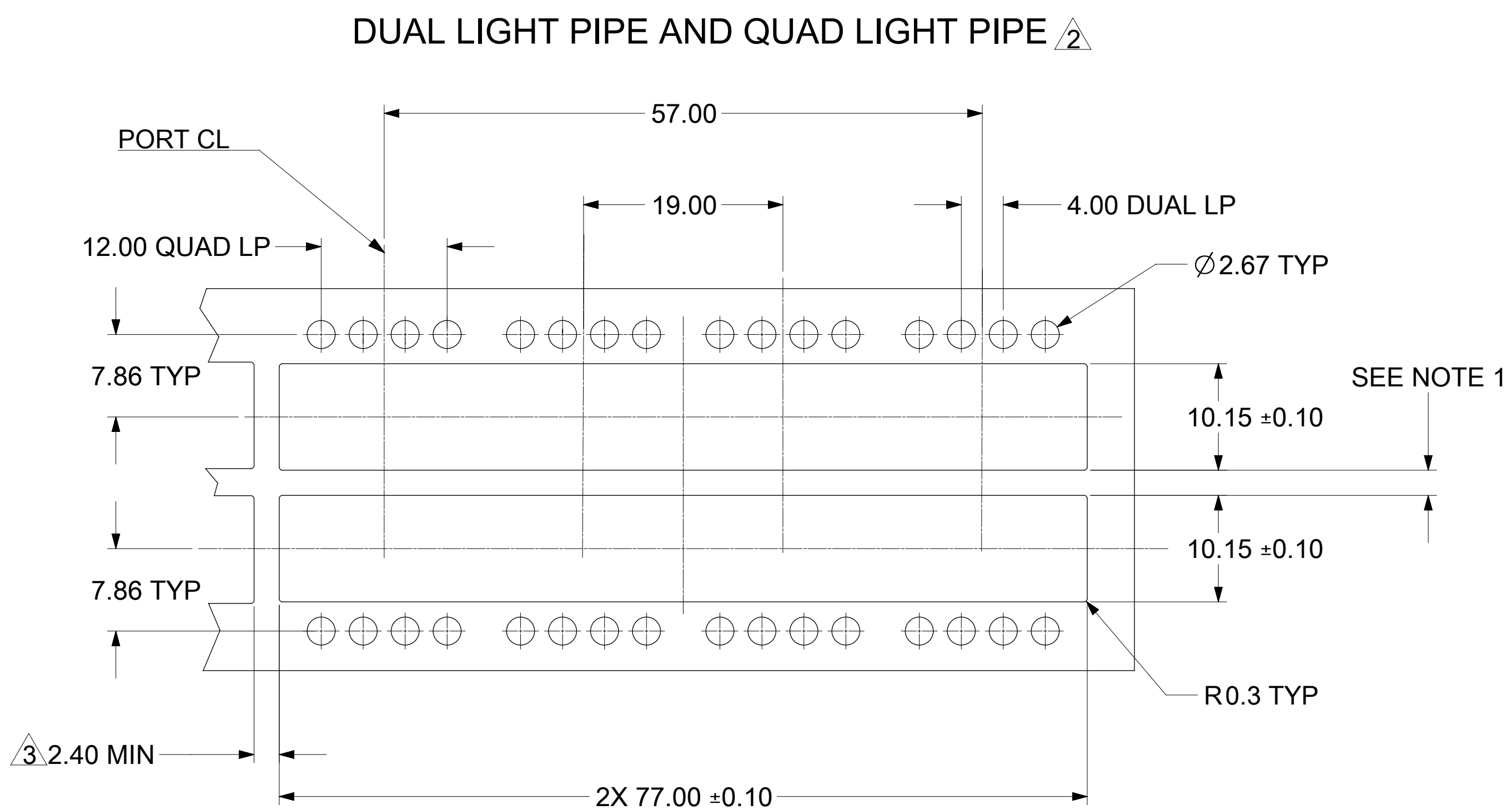
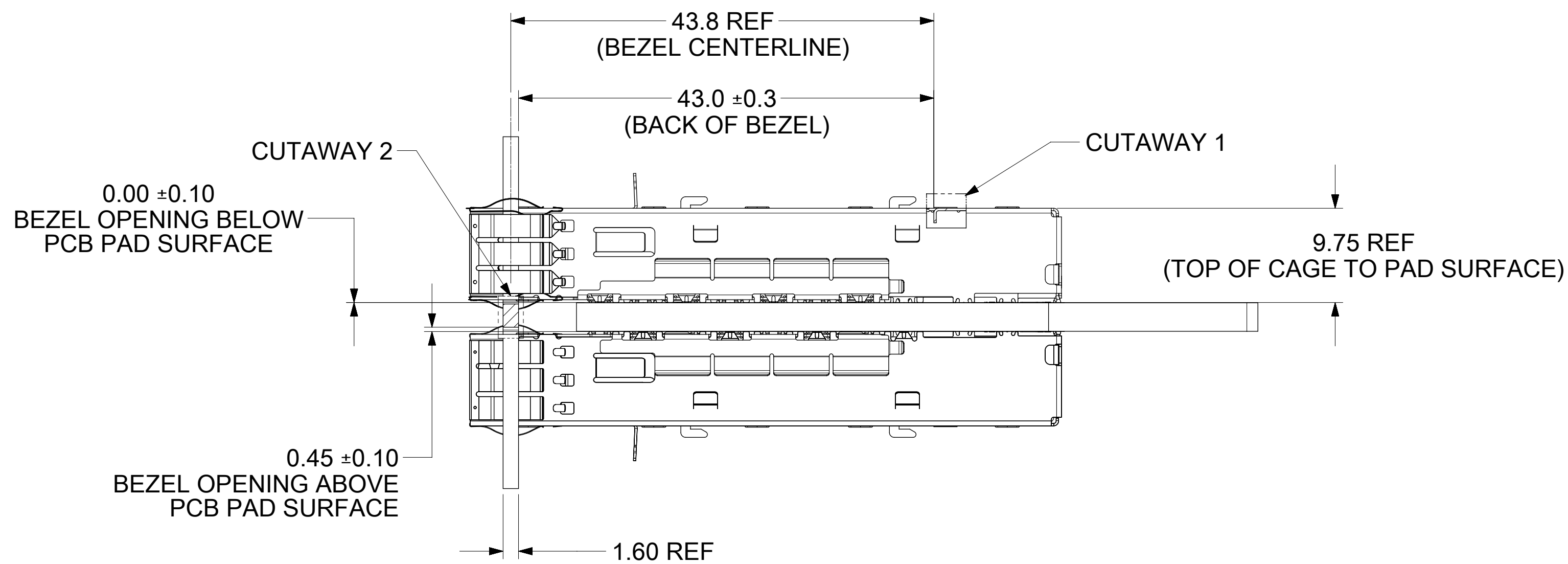
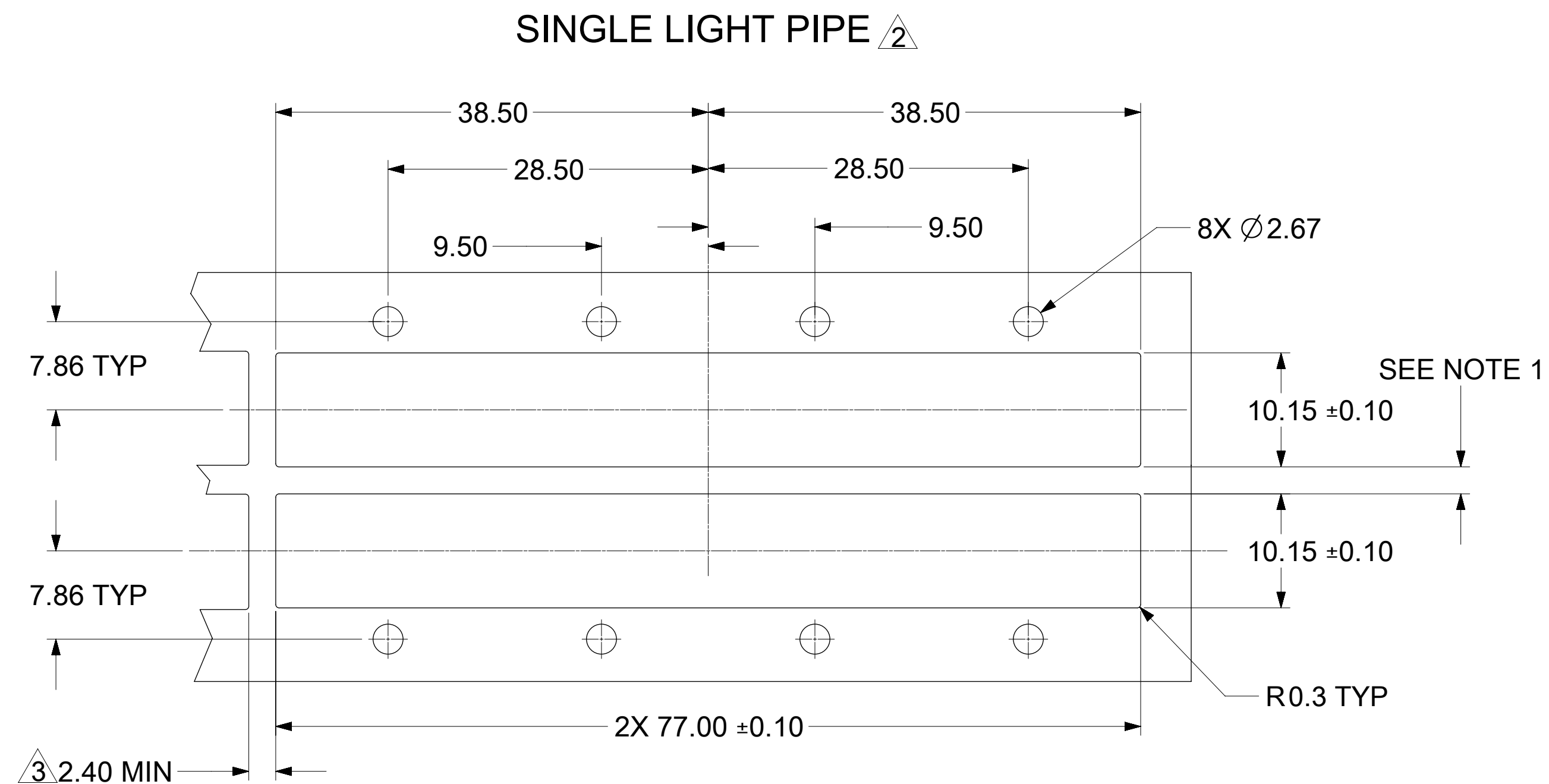

- NOTE:
1. PCB THICKNESS VARIATION MUST BE CONSIDERED WHEN DETERMINING BEZEL OPENING LOCATION.
 2. NOTED DIMENSIONS ONLY APPLY TO CAGE ASSEMBLIES WITH LIGHT PIPES.
 3. THIS DIMENSION IS FOR REFERENCE ONLY. USER CAN MODIFY IT DEPENDS ON APPLICATION. (THIS DIMENSION VARIES BASED ON DISTANCE OF " HOLE OF ADJACENT CAGE" ON PCB LAYOUT.)

THIS DRAWING CONTAINS INFORMATION THAT IS PROPRIETARY TO MOLEX ELECTRONIC TECHNOLOGIES, LLC AND SHOULD NOT BE USED WITHOUT WRITTEN PERMISSION											
DIMENSION UNITS	SCALE	CURRENT REV DESC: SEE REVISION TABLE									
mm	2.5:1	<p>molex</p> <p>ZQSFP+ 1X4 GANGED CAGE ASSYS W/ SS TAB TYPE SPRING FINGER H/S & L/P OPTIONS</p> <p>PRODUCT CUSTOMER DRAWING</p>									
GENERAL TOLERANCES (UNLESS SPECIFIED)											
ANGULAR TOL	± 1.0°										
4 PLACES	±										
3 PLACES	±										
2 PLACES	± 0.13	EC NO: 698865	DRWN: KRISHH1	2022/02/17	DOCUMENT NUMBER				DOC TYPE	DOC PART	REVISION
1 PLACE	± 0.25	DRWN: KRISHH1	2022/02/17	1000173200				PSD	ASY	A	
0 PLACES	±	APPR: JCHIANG	2022/03/21	SEE P/N TABLE				GENERAL MARKET	SHEET NUMBER		
DRAFT WHERE APPLICABLE MUST REMAIN WITHIN DIMENSIONS		THIRD ANGLE PROJECTION	DRAWING	SERIES	MATERIAL NUMBER	CUSTOMER	6 OF 8				
			D-SIZE	100017							

BEZEL AND BOARD POSITION DIMENSIONS
FOR SINGLE SIDE MOUNTING

SINGLE LIGHT PIPE ²

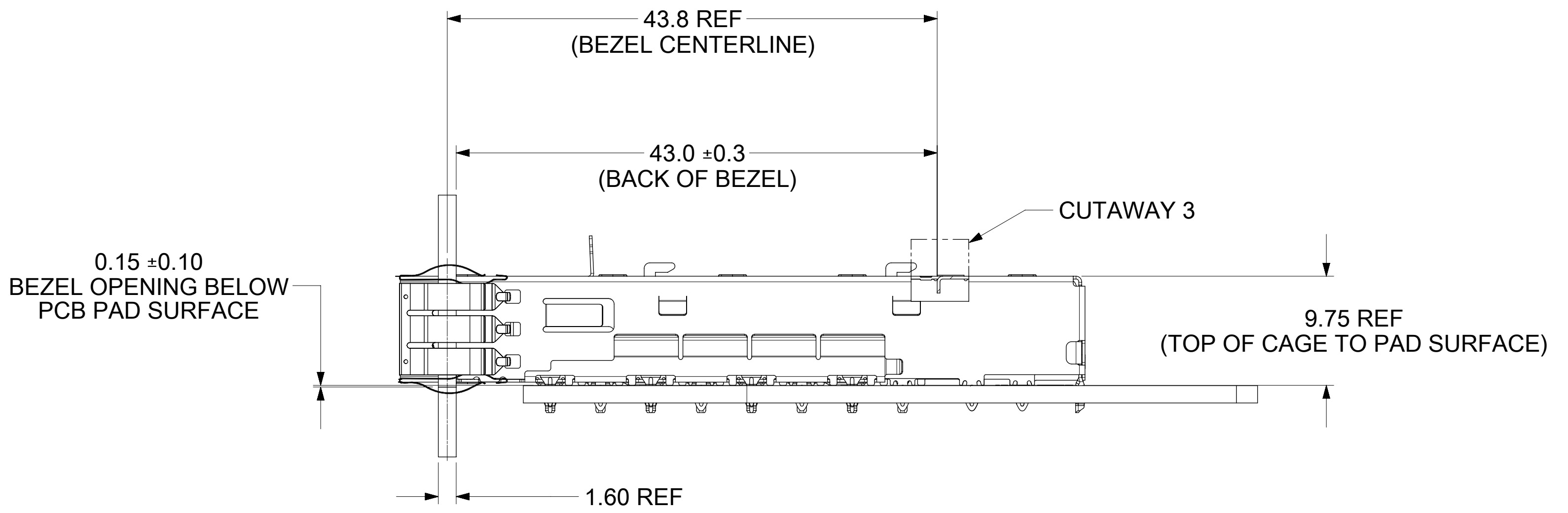
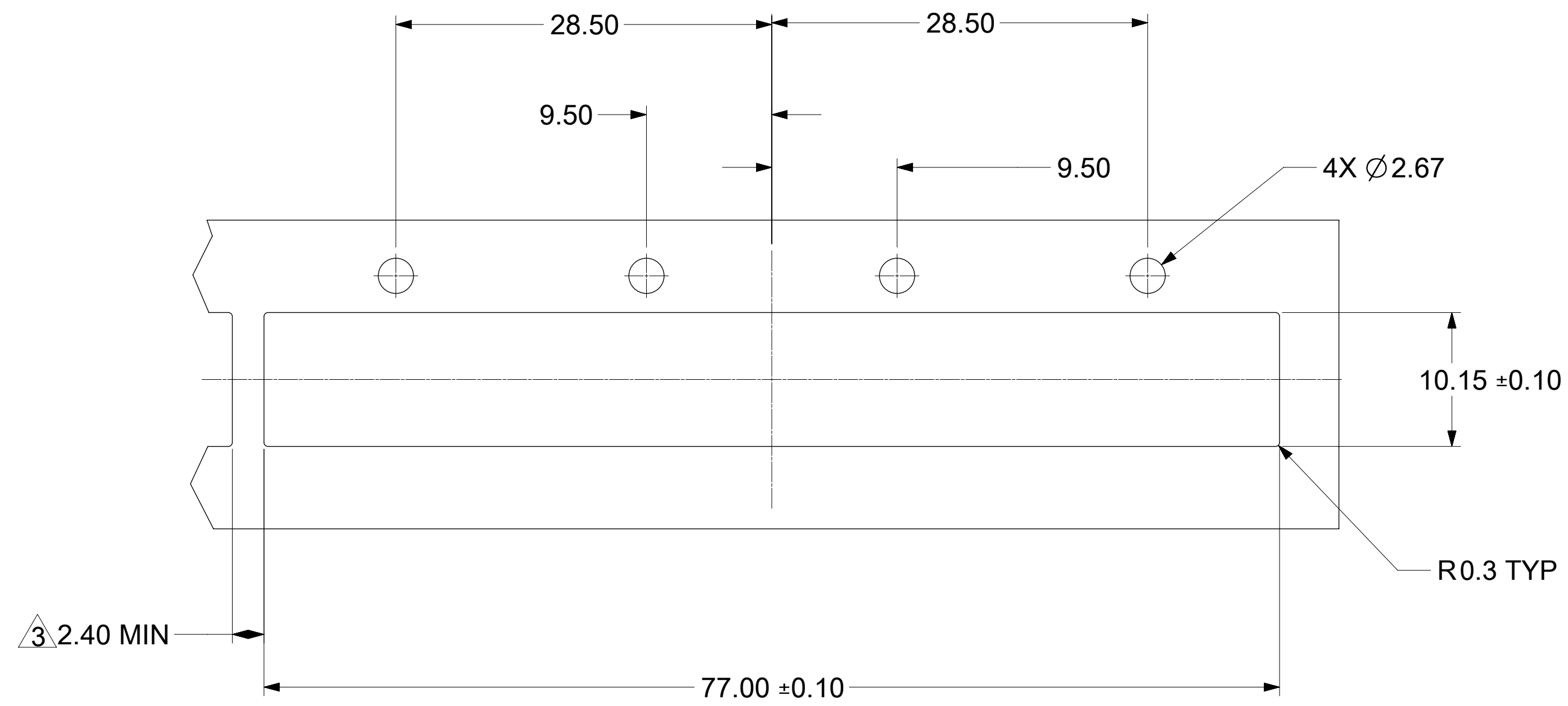

DUAL LIGHT PIPE AND QUAD LIGHT PIPE ²

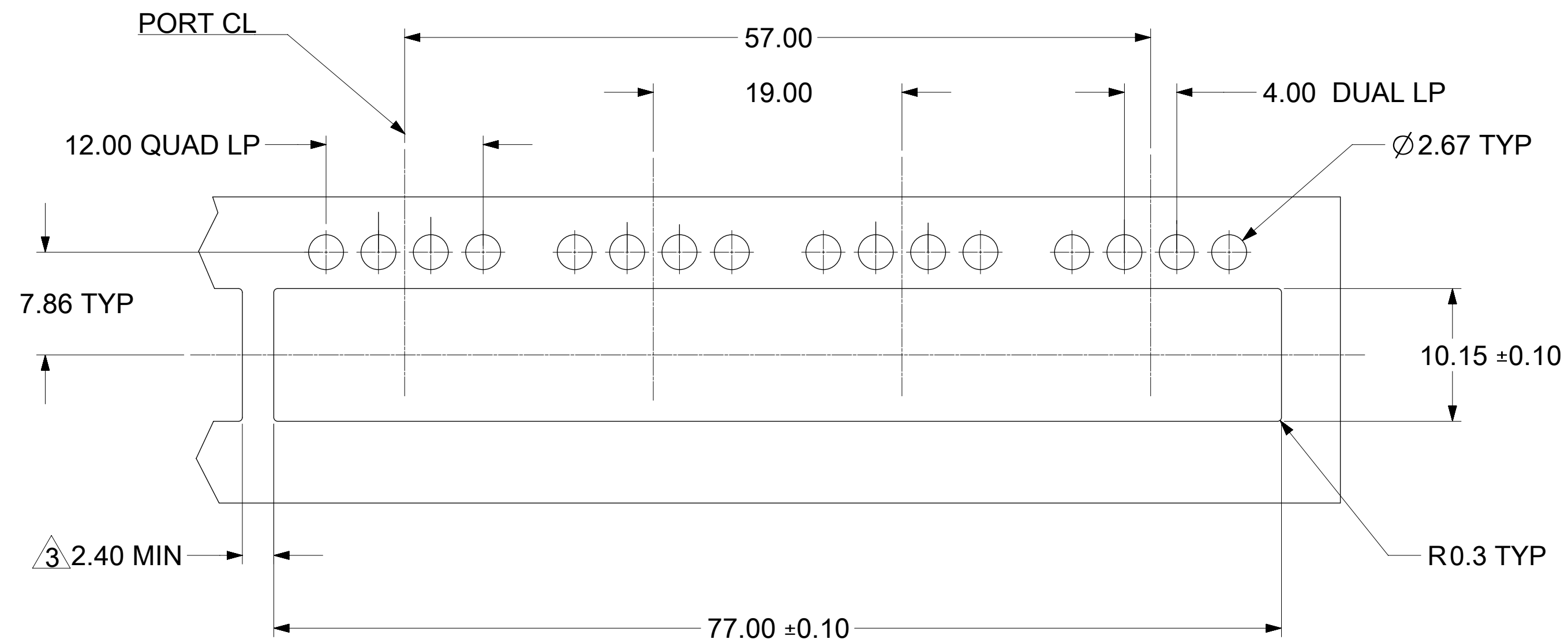

THIS DRAWING CONTAINS INFORMATION THAT IS PROPRIETARY TO MOLEX ELECTRONIC TECHNOLOGIES, LLC AND SHOULD NOT BE USED WITHOUT WRITTEN PERMISSION									
DIMENSION UNITS	SCALE	CURRENT REV DESC: SEE REVISION TABLE							
mm	3:1	<p>molex</p> <p>ZQSFP+ 1X4 GANGED CAGE ASSY'S W/ SS TAB TYPE SPRING FINGER H/S & L/P OPTIONS</p> <p>PRODUCT CUSTOMER DRAWING</p> <p>DOCUMENT NUMBER: 1000173200 DOC TYPE: PSD DOC PART: ASY REVISION: A</p> <p>MATERIAL NUMBER: SEE P/N TABLE CUSTOMER: GENERAL MARKET SHEET NUMBER: 7 OF 8</p>							
GENERAL TOLERANCES (UNLESS SPECIFIED)									
ANGULAR TOL	± 1.0°								
4 PLACES	±								
3 PLACES	±								
2 PLACES	± 0.13								
1 PLACE	± 0.25	EC NO: 698865	DRWN: KRISHH1	2022/02/17					
0 PLACES	±	CHK'D: TKUMARKC	2022/03/10						
DRAFT WHERE APPLICABLE MUST REMAIN WITHIN DIMENSIONS		THIRD ANGLE PROJECTION	DRAWING	SERIES					
			D-SIZE	100017					

NOTE:
 1. PCB THICKNESS VARIATION MUST BE CONSIDERED WHEN DETERMINING BEZEL OPENING LOCATION.
² NOTED DIMENSIONS ONLY APPLY TO CAGE ASSEMBLIES WITH LIGHT PIPES.
³ THIS DIMENSION IS FOR REFERENCE ONLY. USER CAN MODIFY IT DEPENDS ON APPLICATION. (THIS DIMENSION VARIES BASED ON DISTANCE OF " HOLE OF ADIACENT CAGE" ON PCB LAYOUT.)

DOCUMENT STATUS	P1	RELEASE DATE	2022/03/21 02:37:39
-----------------	----	--------------	---------------------

