

General Description

The AOZ7675QI is a flyback receiver in primary side that targeted for power supply solution. It receives the ON time information signal from secondary side converter to drive integrated main MOSFET in primary side. The integrated high-voltage (HV) device provides fast start-up function.

The AOZ7675QI features include multiple protection functions such as V_{DD} under-voltage lockout, cycle-by-cycle current limit, V_{DD} over-voltage protection, secondary rectifier short-circuit protection, current sense pin open-circuit protection and internal over-temperature protection.

The AOZ7675QI is available in a 7mm×7mm QFN-20L package.

Features

- Integrated HV start-up device
- Integrated with HV MOSFET
- 100kHz maximum start-up switching frequency
- V_{DD} over-voltage protection
- Under-voltage lockout (6.7V/15.5V)
- Current sense leading edge blanking time
- Cycle by cycle current limit
- Secondary rectifier short-circuit protection
- CS pin open-circuit protection
- Internal over-temperature protection
- Thermally enhanced 20-pin 7x7 QFN

Applications

- Smart charger
- Adapter
- TV and monitor applications
- Open frame power supply



Typical Application

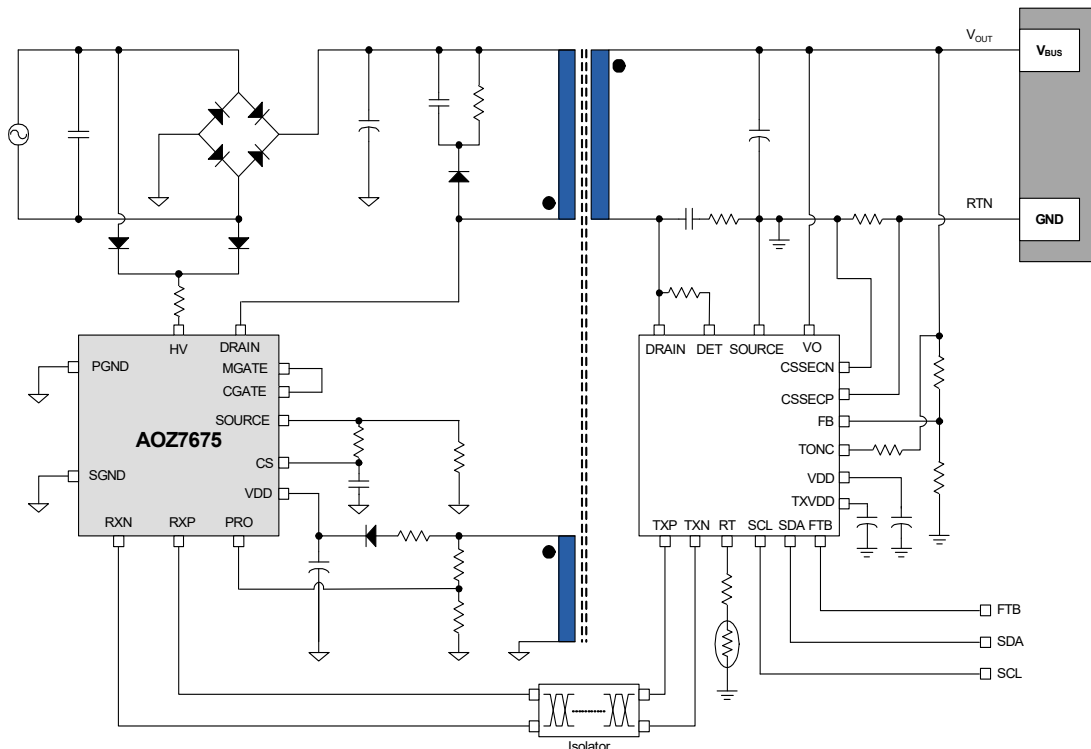

Ordering Information

Part Number	Ambient Temperature Range	Package	Environmental
AOZ7675QI	-40°C to +125°C	QFN 7x7-20L	Green Product



AOS Green Products use reduced levels of Halogens, and are also RoHS compliant.

Pin Configuration

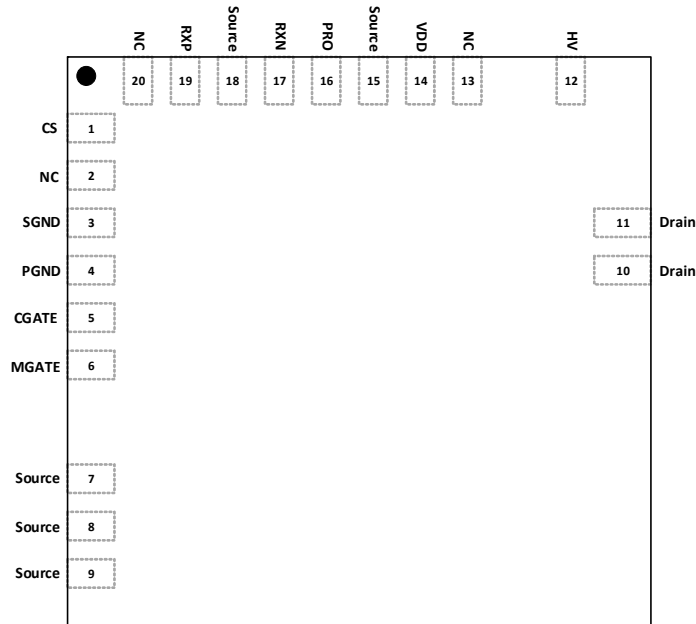

**20-Pin 7mm x 7mm QFN
(Top View)**

Pin Description

Pin Number	Pin Name	Pin Function
1	CS	Current sense input pin.
3	SGND	Signal GND
7,8,9,15,18	SOURCE	Source of the MOSFET.
4	PGND	Power GND.
5	CGATE	The gate pin of controller.
6	MGATE	The gate pin of the integrated MOSFET
10, 11	DRAIN	Drain of the integrated MOSFET.
12	HV	High voltage start-up current source.
2, 13, 20	NC	No connection.
14	VDD	The VDD is the bias-supply input pin to the controller.
16	PRO	Protection pin.
17	RXN	ON time information receiver pin.
19	RXP	ON time information receiver pin.

Absolute Maximum Ratings

Exceeding the Absolute Maximum Ratings may damage the device.

Parameter	Rating
V _{HV}	-0.3V to 500V
V _{DRAIN}	-0.7V to 700V
V _{DD} , V _{CGATE}	-0.3V to 40V
V _{CS} , V _{RXP} , V _{RXN} , V _{PRO}	-0.3V to 7V
V _{MGATE}	-0.3V to 20V
Junction Temperature (T _J)	+150°C
Storage Temperature (T _S)	-65°C to +150°C
ESD HBM ⁽¹⁾	4kV
ESD CDM ⁽¹⁾	1kV

Notes:

1. Devices are inherently ESD sensitive, handling precautions are required. Human body model rating: 1.5kΩ in series with 100pF.
2. 1x1inch, 2-layer PCB, follow JEDEC standard.

Recommended Operating Conditions

The device is not guaranteed to operate beyond the Maximum Recommended Operating Conditions.

Parameter	Rating
Supply Voltage (V _{DD})	8V to 33V
Ambient Temperature (T _A)	-40°C to +125°C
Package Thermal Resistance	25°C/W ⁽²⁾

Electrical Characteristics

V_{DD}=15V, T_A = -25°C to 85°C, unless otherwise specified.

Symbol	Parameter	Conditions	Min	Typ	Max	Units
MOSFET						
R _{DS(ON)}	ON State Resistance	Static, I _{DRAIN} = 1A, V _{DD} = 10V, T _J = 25°C		0.15	0.2	Ω
HV						
I _{HV}	Supply Current from HV Pin	V _{HV} = 100V, V _{DD} = 0V, converter OFF	1	3	4.5	mA
I _{HV_LC}	Leakage Current from HV Pin	V _{HV} = 500V, V _{DD} = 18V, converter ON		0.8		μA
VDD						
V _{DD_OVP}	VDD Over-Voltage Protection Level		34	36	38.2	V
t _{D_OVP}	VDD Over-Voltage Protection Debounce Time ⁽¹⁾			20		μs
V _{DD_ON}	Turn-ON Threshold Voltage		14.0	15.5	17.0	V
V _{DD_UVLO}	Turn-OFF and Under Voltage Lock Out		6.2	6.7	7.2	V
I _{DD_OP}	Operation Current	V _{DD} = 15V, converter ON, f _S = 80kHz	0.6	1.2	1.8	mA
I _{DD_SKIP}	Skip Mode Operation Current	V _{DD} = 7V		500	550	μA
I _{DD_DIS}	Disable Mode Operation Current	V _{DD} = 15V, V _{DD_OVP} is enabled or no GATE output		70	100	μA
Frequency						
f _{OSC}	Start-up Operation Frequency	V _{PRO} = 1V		100		kHz
f _{OSC1}		V _{PRO} = 0.5V		50		kHz
Protection Function						
V _{PRO_MIN}	Min. Clamp Voltage	I _{PRO} = -0.1mA	0.15	0.2	0.25	V
V _{DISH}	Disable Voltage Level (High)		1.4	1.5	1.6	V

Electrical Characteristics (Continued)
 $V_{DD}=15V$, $T_A = -25^{\circ}C$ to $85^{\circ}C$, unless otherwise specified.

Symbol	Parameter	Conditions	Min	Typ	Max	Units
t_{DISHBN}	Blanking Time		0.6	0.8	1	μs
t_{DISHDB}	V_{DISH} Debounce Cycles			4		Cycles
Gate Drive						
V_{G_CLAMP}	GATE Clamping Voltage	$V_{DD} = 15V$		12		V
t_{LEB}	Leading Edge Blanking Time		300	350	420	ns
t_{PD}	Propagation Delay Time			50	100	ns
Soft-start						
t_{SS_OFF}	Soft-Start Time for Shut Down			18	24	ms
t_{SS_CS}	Soft-Start Time for Current Limit		5	7	9	ms
Current LIMIT						
V_{CSL}	General Continuous Operation Limited Current Sense Level	$I_{PRO} = 120\mu A$	285	300	315	mV
V_{CSH}	Fast Over Current Protection Limit			0.75		V
t_{OCPH}	Fast OCP for Auto Restart	$V_{CS} > 750mV$ and happening continuous		4		Cycles
Receiver						
t_{RD}	Delay Time for RX Rising Signal to GATE ON				100	ns
t_{FD}	Delay Time for RX Falling Signal to GATE OFF				100	ns
Over temperature protection						
T_{SD}	Thermal Shutdown	T_J Rising		145		$^{\circ}C$
T_{SDR}	Thermal Shutdown Recovery Threshold	T_J Falling		125		$^{\circ}C$

Functional Block Diagram

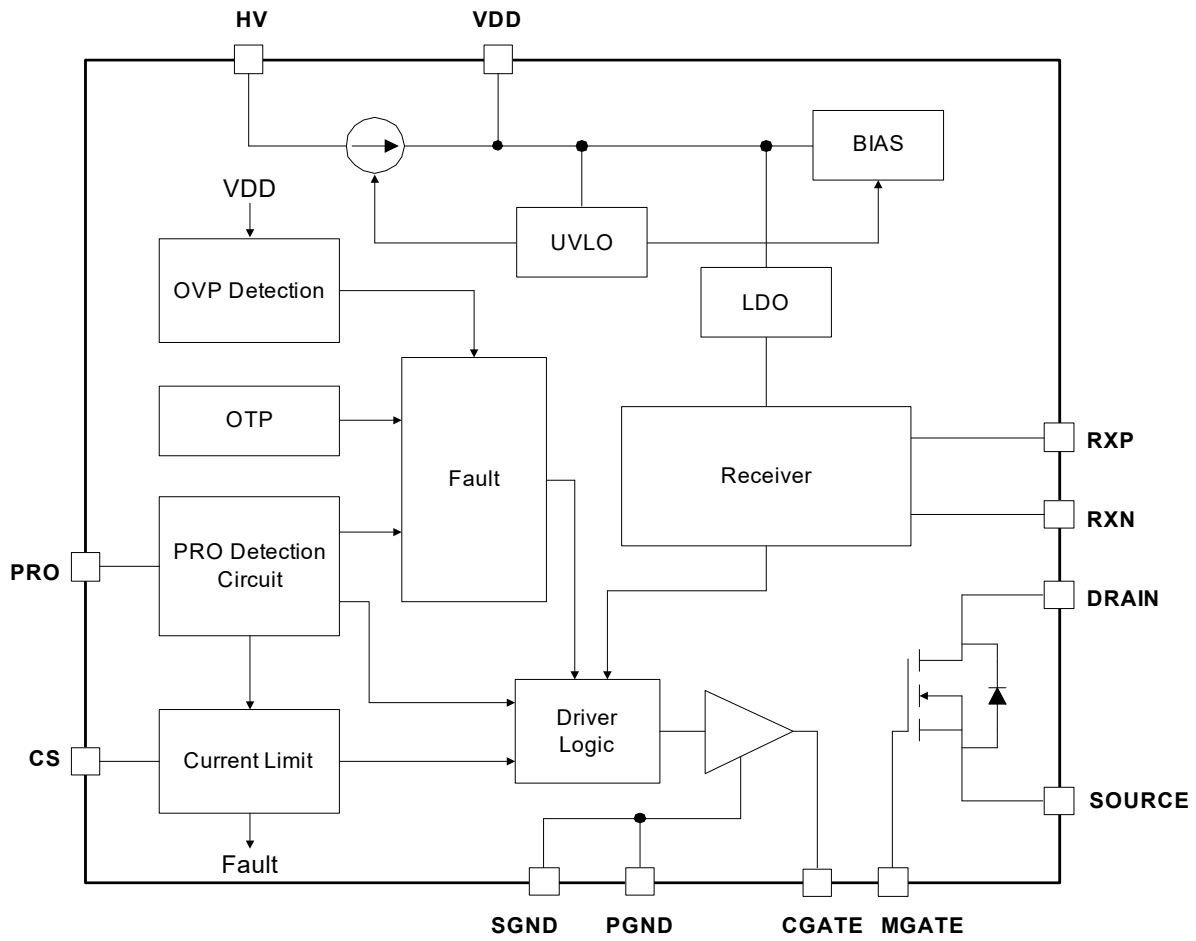

Typical Characteristics

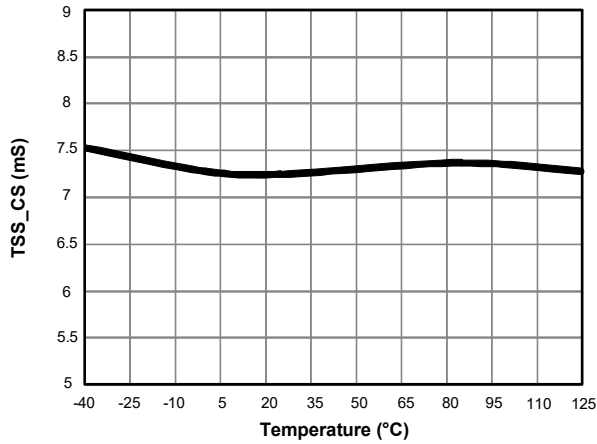

Figure 1. Soft Start Time for Current Limit vs. Temperature

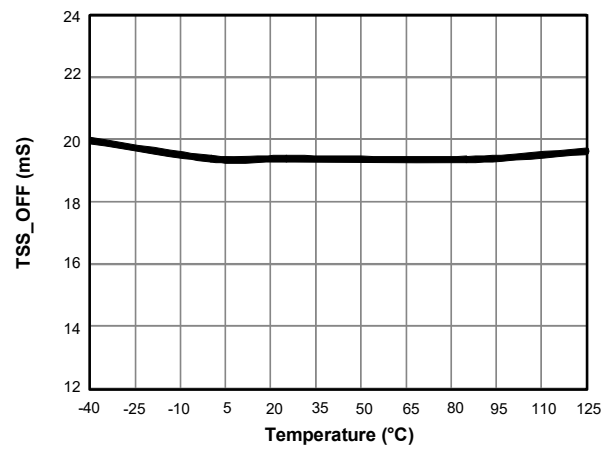

Figure 2. Soft Start Time for Shut Down vs. Temperature

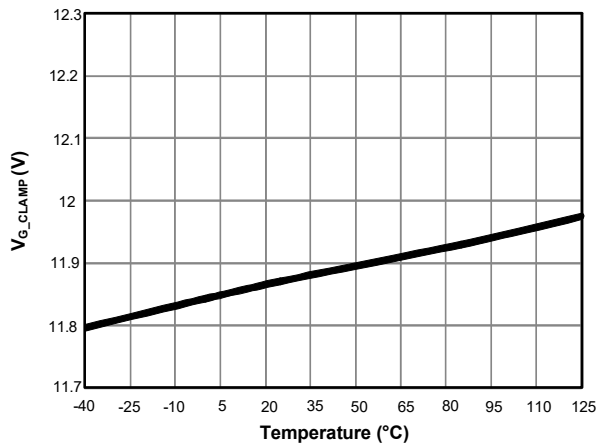

Figure 3. Gate Clamping Voltage vs. Temperature

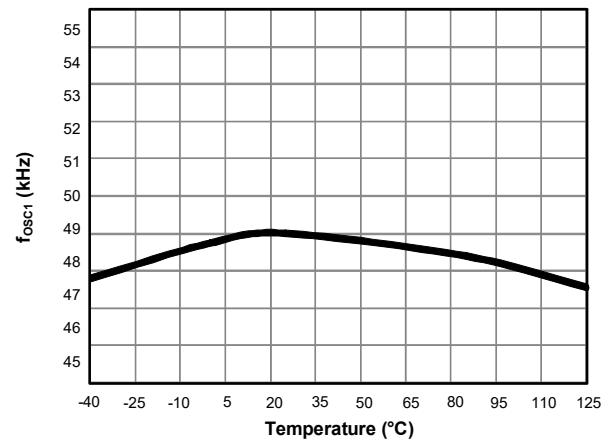

Figure 4. Minimum of the Start-up Operation Frequency vs. Temperature

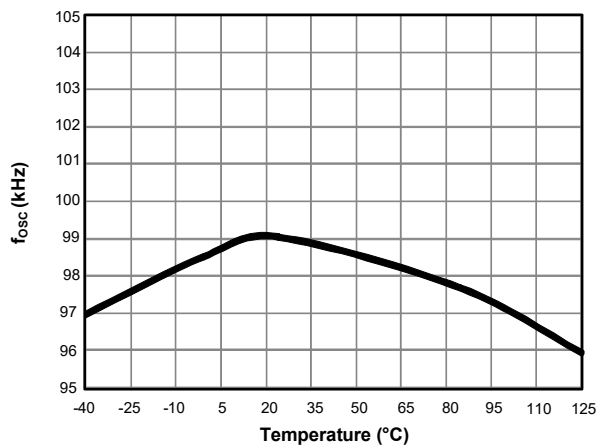

Figure 5. Maximum of the Start-up Operation Frequency vs. Temperature

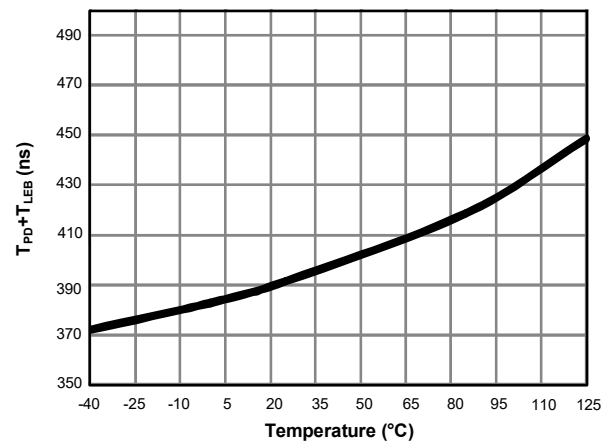

Figure 6. Minimum of the Turn-on Period vs. Temperature

Typical Characteristics

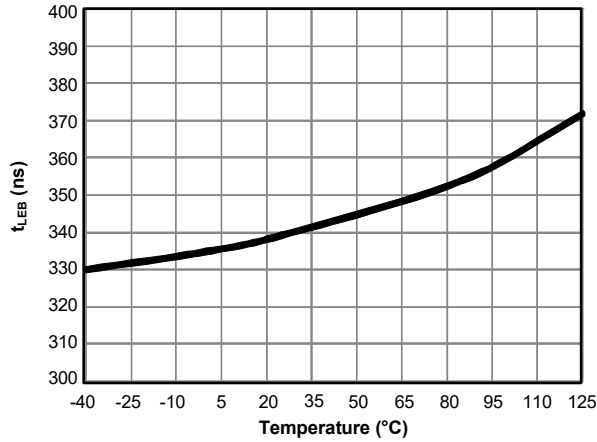

Figure 7. Leading Edge Blanking Time vs. Temperature

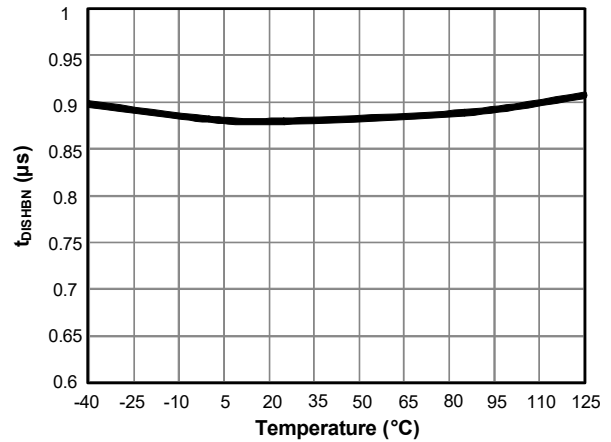

Figure 8. The Blanking Time of the Disable Voltage Level vs. Temperature

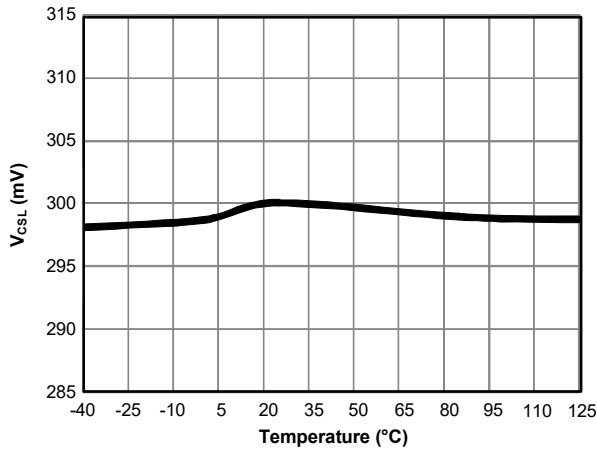

Figure 9. General Continuous Operation Current Sense Limit vs. Temperature

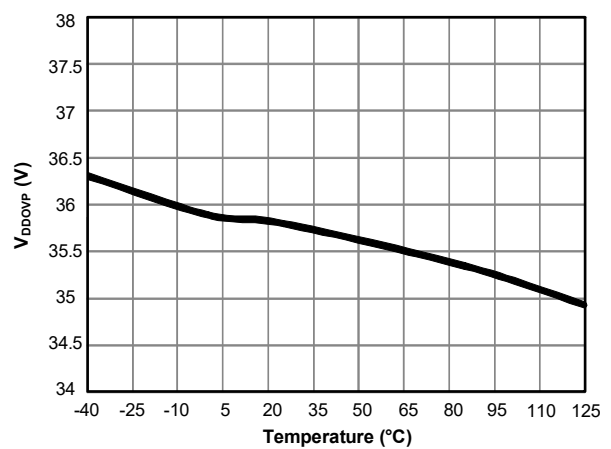

Figure 10. V_{DD} Over-Voltage Protection Level vs. Temperature

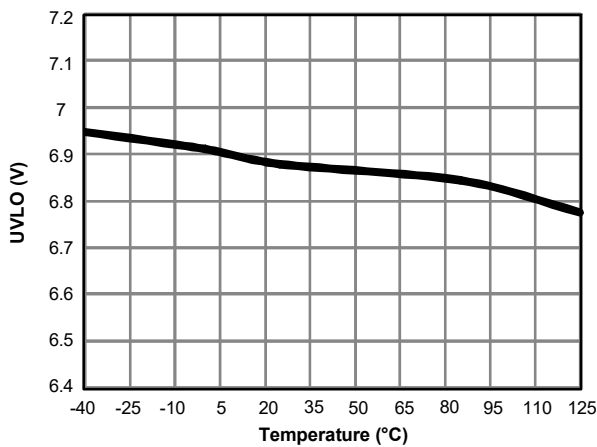

Figure 11. Turn-OFF and Under Voltage Lock Out vs. Temperature

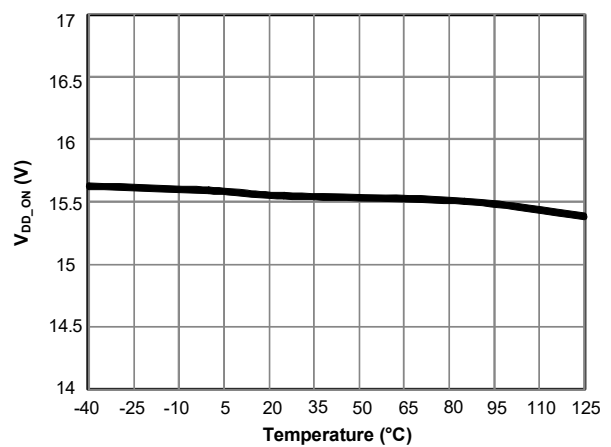

Figure 12. Turn-ON Threshold Voltage vs. Temperature

Detailed Description

HV Start-Up

There is a high-voltage (HV) device which is designed as a current source to charge the VDD capacitor during start-up. This current source will be turned off for reducing the power consumption after the AOZ7675QI is powered on. The HV pin should be connected to the input terminals through the rectifier diodes and a series resistor, the series resistor is recommended to be 10k Ω .

Soft Start

The AOZ7675QI has an internal soft start feature to limit inrush current and ensure the output voltage ramps up smoothly to the regulation voltage. If the AOZ7675QI never receives the ON time information from the secondary side converter, the AOZ7675QI will be shut down after 18ms (t_{SS_OFF}) from start-up.

ON Time Receiver

The AOZ7675QI receives the ON time information from the secondary side converter through the RXP and RXN pins and send the ON time signal to the driver. The ON time width of the switching pulse varies according to the ON time signal.

VDD Over-Voltage Protection

The output voltage can be sensed roughly from the VDD pin. When the VDD voltage exceeds the VDD OVP level (V_{DD_OVP}), the converter will be shut down after the VDD OVP debounce time (t_{D_OVP}) and then return to the start state.

PRO Protection

The output voltage can be sensed indirectly by monitoring the auxiliary winding voltage. When the PRO voltage during turn-off period exceeds the PRO disable voltage level (V_{DISH}), the converter will be shut down after the V_{DISH} debounce cycles (t_{DISHDB}) and then return to the start state.

Cycle-by-Cycle Current Limit

The AOZ7675QI detects the primary current through CS pin, and the CS peak voltage of each switching cycle is limited to V_{CSL} . The voltage across the current-sensing resistor R_{CS} is fed into the CS pin for current limit detection.

When the fault occurs due to transformer short circuit or secondary rectifier short circuit, and the large current will flow through the main MOSFET at turn-on period, and this will cause damage on power components. In order to protect the system, Fast over current protection function is added. If the CS voltage reaches V_{CSH} , the converter will be shut down after four consecutive cycles and then return to the start state.

CS Pin Open-Circuit Protection

The CS pin features open-loop protection to pass the CS pin single fault testing. When the CS pin is opened, the CS will be pulled high by internal circuit and CS pin voltage will higher than V_{CSH} and the converter will be shut down after four consecutive cycles and then return to the start state.

Over-Temperature Protection

The AOZ7675QI provides an internal OTP protection function. If the junction temperature reaches the OTP threshold, the AOZ7675QI will stop switching until the junction temperature decreases below the OTP recovery temperature.

Package Dimensions, QFN7x7-20L, EP1_S

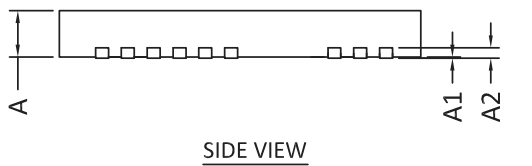
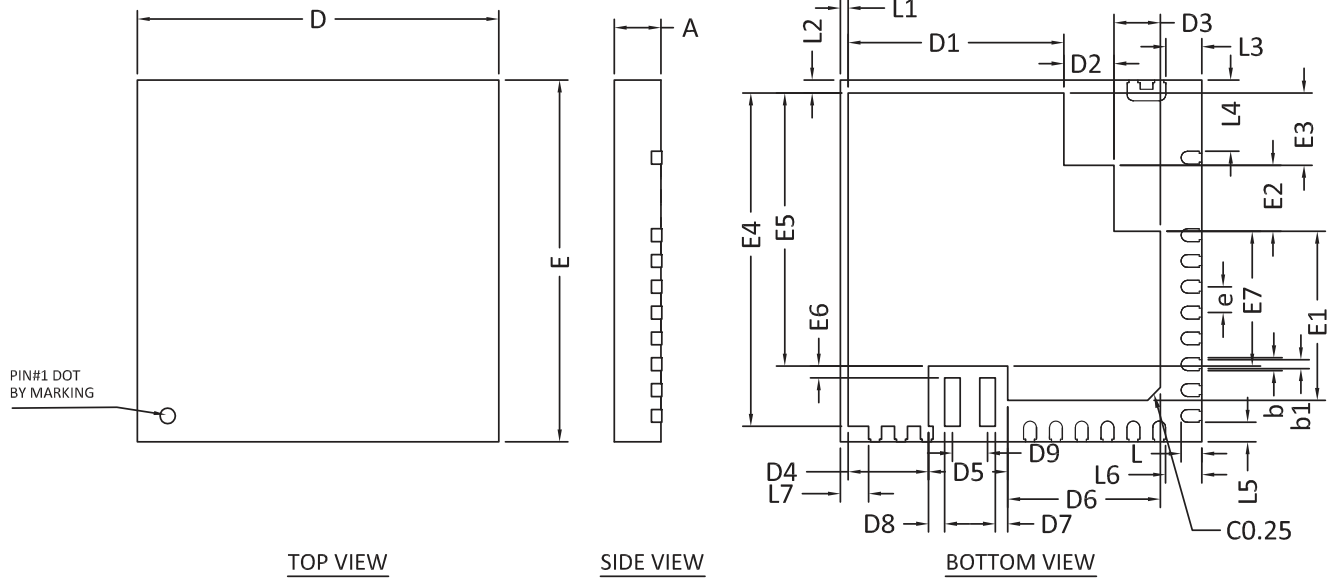

RECOMMENDED LAND PATTERN

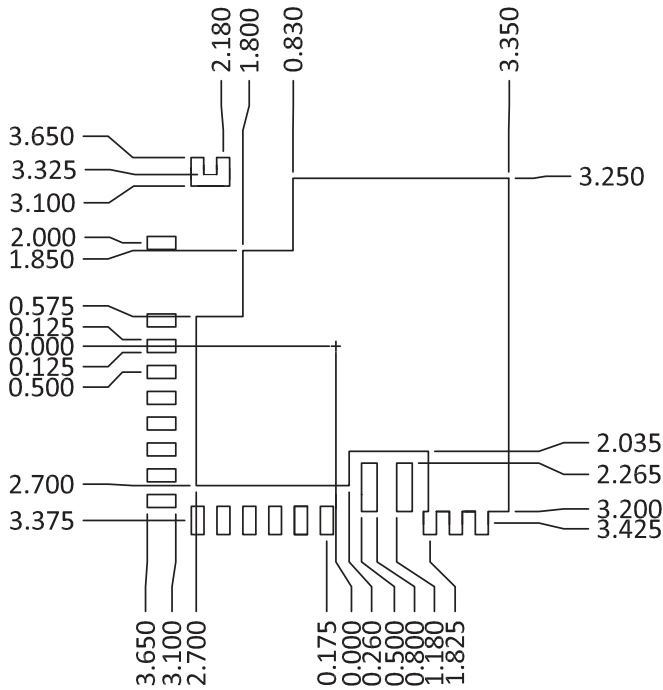

SYMBOLS	DIMENSION IN MM			DIMENSION IN INCHES		
	MIN	NOM	MAX	MIN	NOM	MAX
A	0.80	0.90	1.00	0.031	0.035	0.039
A1	0.00	-	0.05	0.000	-	0.002
A2	0.2REF			0.008REF		
E	6.90	7.00	7.10	0.272	0.276	0.280
D	6.90	7.00	7.10	0.272	0.276	0.280
D1	4.08	4.18	4.28	0.161	0.165	0.169
D2	0.87	0.97	1.07	0.034	0.038	0.042
D3	0.80	0.90	1.00	0.031	0.035	0.039
D4	1.46	1.56	1.66	0.057	0.061	0.065
D5	1.43	1.53	1.63	0.056	0.060	0.064
D6	2.86	2.96	3.06	0.113	0.117	0.120
D7	0.14	0.24	0.34	0.006	0.009	0.013
D8	0.21	0.31	0.41	0.008	0.012	0.016
D9	0.58	0.68	0.78	0.023	0.027	0.031
E1	3.18	3.28	3.38	0.125	0.129	0.133
E2	1.18	1.28	1.38	0.046	0.050	0.054
E3	1.30	1.40	1.50	0.051	0.055	0.059
E4	6.35	6.45	6.55	0.250	0.254	0.258
E5	5.19	5.29	5.39	0.204	0.208	0.212
E6	0.13	0.23	0.33	0.005	0.009	0.013
E7	2.51	2.61	2.71	0.099	0.103	0.107
L	0.30	0.40	0.50	0.012	0.016	0.020
L1	0.05	0.15	0.25	0.002	0.006	0.010
L2	0.15	0.25	0.35	0.006	0.010	0.014
L3	0.60	0.70	0.80	0.024	0.028	0.031
L4	1.28	1.38	1.48	0.050	0.054	0.058
L5	0.28	0.38	0.48	0.011	0.015	0.019
L6	0.60	0.70	0.80	0.024	0.028	0.031
L7	0.45	0.55	0.65	0.018	0.022	0.026
b	0.15	0.25	0.35	0.006	0.010	0.014
b1	0.08	0.18	0.28	0.003	0.007	0.011
e	0.50BSC			0.02BSC		

UNIT: mm

NOTE
CONTROLLING DIMENSION IS MILLIMETER.
CONVERTED INCH DIMENSIONS ARE NOT NECESSARILY EXACT.

Tape and Reel, QFN7x7-20L, EP1_S

QFN7x7_20L_EP1_S Carrier Tape

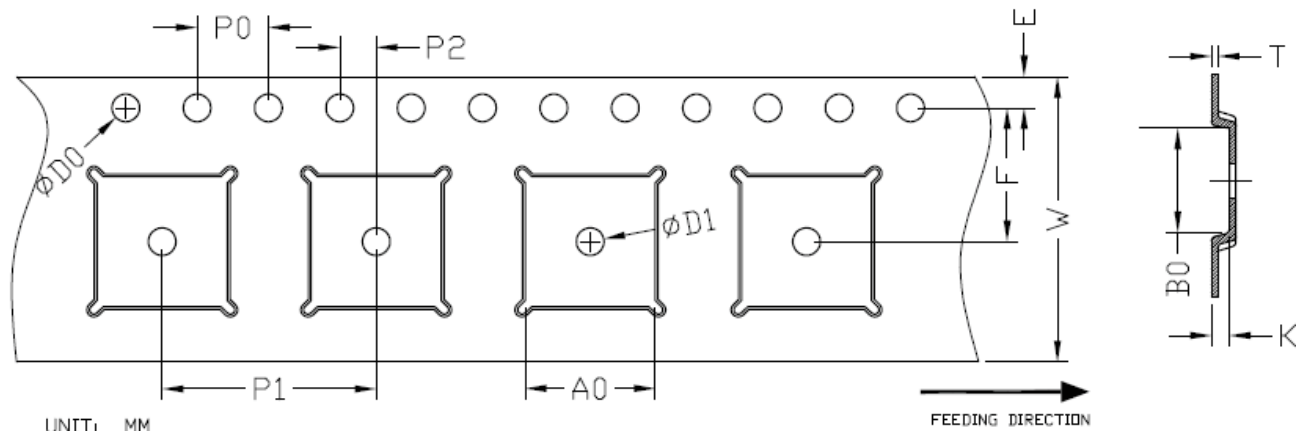

UNIT: MM

FEEDING DIRECTION

PACKAGE	A0	B0	K0	D0	D1	W	E	F	P0	P1	P2	T
QFN7x7	7.30 ±0.1	7.30 ±0.1	1.20 ±0.1	∅1.55 ±0.10	∅1.50 MIN.	16.00 +0.3 -0.1	1.75 ±0.1	7.50 ±0.1	4.00 ±0.1	12.00 ±0.1	2.00 ±0.10	0.30 ±0.05

QFN7x7_20L_EP1_S Reel

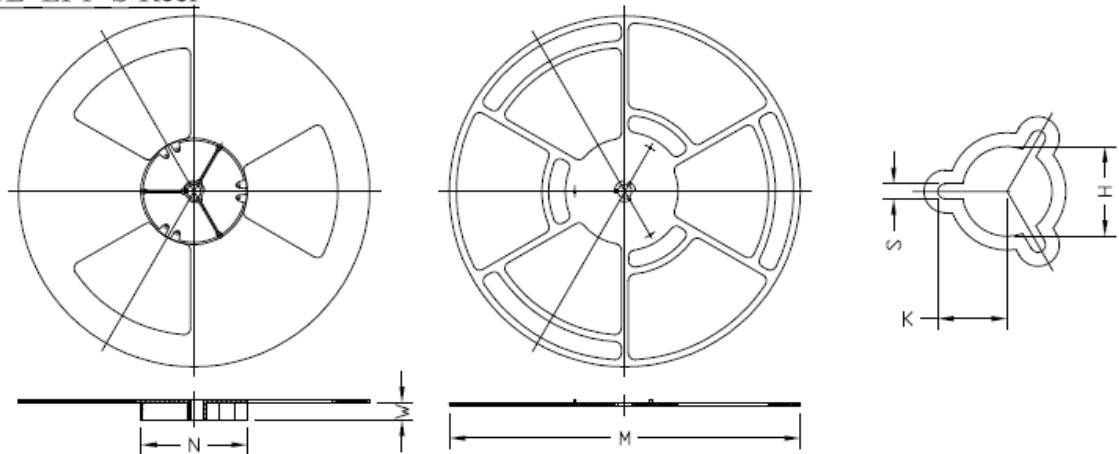

UNIT: MM

TAPE SIZE	REEL SIZE	M	N	W	H	K	S
16 mm	∅330	∅330.00 +0.25 -4.00	∅100.00 ±0.2	16.4 +2.0 -0.0	∅13.00 +0.50 -0.20	10.5 ±0.25	2.2 ±0.25

QFN7x7_20L_EP1_S Tape

Leader / Trailer
& Orientation

Unit Per Reel:
3000pcs

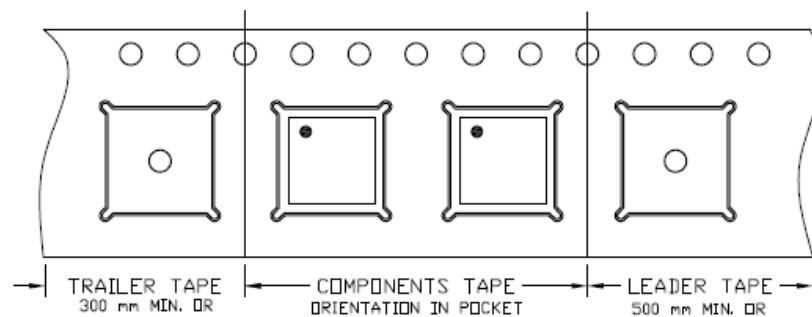

Part Marking

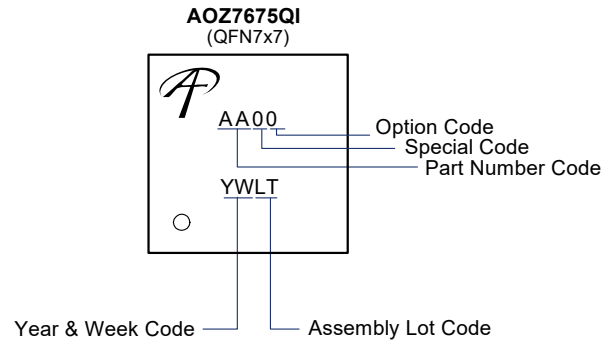

LEGAL DISCLAIMER

Applications or uses as critical components in life support devices or systems are not authorized. AOS does not assume any liability arising out of such applications or uses of its products. AOS reserves the right to make changes to product specifications without notice. It is the responsibility of the customer to evaluate suitability of the product for their intended application. Customer shall comply with applicable legal requirements, including all applicable export control rules, regulations and limitations.

AOS' products are provided subject to AOS' terms and conditions of sale which are set forth at:

http://www.aosmd.com/terms_and_conditions_of_sale

LIFE SUPPORT POLICY

ALPHA AND OMEGA SEMICONDUCTOR PRODUCTS ARE NOT AUTHORIZED FOR USE AS CRITICAL COMPONENTS IN LIFE SUPPORT DEVICES OR SYSTEMS.

As used herein:

1. Life support devices or systems are devices or systems which, (a) are intended for surgical implant into the body or (b) support or sustain life, and (c) whose failure to perform when properly used in accordance with instructions for use provided in the labeling, can be reasonably expected to result in a significant injury of the user.
2. A critical component in any component of a life support, device, or system whose failure to perform can be reasonably expected to cause the failure of the life support device or system, or to affect its safety or effectiveness.