

Series 408 Sealed Potentiometer
1/2 in. sq. 0.5 Watt

Series 409 Sealed Potentiometer
1/2 in. sq. 1.0 Watt

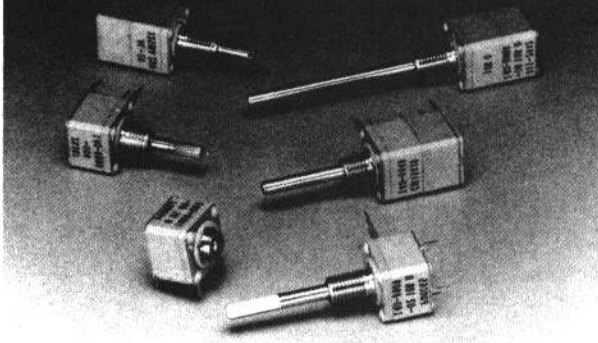

408: Modular Style, Conductive Plastic

409: Modular Style, Thick-Film Cermet

Description

The series 408 and 409 are high-performance potentiometers, designed to meet wave soldering applications for mounting to PC boards.

They are also available with S.P.S.T. or S.P.D.T. rotary switch modules, S.P.D.T. push-pull or momentary switch modules and/or potentiometer modules in multiple sections up to three sections.

Features

- **Compact** - 1/2 in. (12.7mm) miniature, totally sealed, modular size.
- **Precision Made** - screen-printed conductive plastic and thick-film cermet elements.
- **Cost-effective** - Elimination of hand soldering.
- **Rugged** - Horizontal or vertical mountings with support plates. Nickel-plated brass shaft and bushings in various diameters and lengths. Insert molded gold plated terminals for strength.
- **Stability** - Series 408 - 40°C to +120°C; Series 409 - 40°C to 150°C operating temperature.

Series 408 Electrical Specifications

Series 409 Electrical Specifications

<i>Resistance Tolerance</i>	100Ω to 5 Megohms, linear; 500Ω to 2 Megohms, non-linear	Linear: 5Ω to 5 Megohms Taper: 100Ω to 2 Megohms
<i>Resistance Range</i>	Linear, thru 500KΩ, ±10%; above 500K to 5 Megohms, ±20%. Non-linear thru 100KΩ, ±10%; above 100Ω ±20%.	±10% standard; ±5% special. Trimmers ±20%.
<i>End Resistance</i>	Linear, 4Ω maximum each end. Taper low side. 4Ω maximum. High side 1% of total R.	2Ω maximum, 5Ω to 2500Ω. 4Ω maximum, 5KΩ and above.
<i>Power Rating</i>	.5 watt @ 70°C. Derated linearly to zero watts at 120°C. See Chart B, page 37. For non linear tapered units or PC mounting, derate by 50%. Trimmer style, derate by 50%.	1 watt @ 85°C. Derate linearly to zero watts at 150°C. For tapered units, trimmers or PC mounting, derate 50%.
<i>Effective Rotation</i>	265° ±5° without rotary switch; 240° ±5° with rotary switch.	250° +10° -5° without rotary switch; 225° +10° -5° with rotary switch.
<i>Dynamic Noise</i>	Standard: Linear single controls maximum initial noise level of 1.5% of total resistance. Measurement made using constant current source and oscilloscope detection technique. Special: 1%.	Standard: Linear single controls maximum initial noise level of 3% of total resistance. Measurement made using constant current source and oscilloscope detection technique. Special: 1.5%

Electrical Specifications continued, next page

Electrical Specifications continued

Electrical Rotation	295° ±5°	295° ±5°
Working Voltage	350 Vdc across end terminals, but power not to exceed rating.	350 Vdc across end terminals, but power not to exceed rating.
Resistance Temperature Characteristics	See Chart C, page 38.	See Chart C, page 38.
Linearity	±5% independent	±5% independent
Non-linear Tapers	Right or left-hand available. See Chart A, page 37.	Right or left-hand available. See Chart A, page 37.
Taper Tolerance	±20% of nominal resistance @ 50% ±3% of mechanical rotation.	±20% of nominal resistance @ 50% ±3% of mechanical rotation.
Voltage Coefficient	.008%/Volt maximum	.008%/Volt maximum
Dielectric Withstanding Voltage	750 Vac for 60 seconds @ ATM pressure. 350 Vac for 6 seconds @ 3.4 in. Hg.	900 Vac for 60 seconds @ ATM pressure. 350 Vac for 60 seconds @ 3.4 in. Hg.

Series 408/409 Mechanical Specifications**Mechanical Rotation**

295° ±5°

Stop Torque

3 lb. in. minimum (metal shaft)

Torque Range

.20 to 3.0 oz. in. (Single); .3 to 3.5 oz. in. (Dual); .4 to 4.5 oz. in. (Triple).

Other torque options available. Please consult Factory.

Torque Variation

Within control .5 oz. in. maximum

Bushing Lengths

.25 in. (6.35mm), .375 in. (9.53mm), .5 in. (12.7mm)

Shafts, Standard

.125 in. (3.18mm) diameter; brass, nickel-plated

Shaft Lengths

Lengths from mounting surface to 3 in. (76.2mm) in 1/64 in. (.397mm) increments

Push-Pull and Momentary Switch

S.P.D.T., 250ma, 30Vdc, push-pull (type BL). Momentary (type BLM).

Rotary Switch

S.P.S.T. or S.P.D.T., CCW or CW, 125ma, 28Vdc. (Type AL).

Mechanical Specifications continued**Seal**

O-ring shaft seal standard all styles, and the complete unit is sealed for wave solder and wash processing. The shaft seal withstands 3 PSI pressure. Mounting seals are available. See Chart D, page 38.

Housing

Thermoplastic polyester, blue. (U.L. SE-O rating).

Hardware

Nut: brass, nickel-plated

Lockwasher: phosphorous bronze, nickel-plated

Solvent Resistance

Housing resistant to trichlorethylene, *Chlorethene NU, Freon TMS, **Freon TMC, toluene, MEK, ethyl acetate and gasoline. For solvents not listed, please consult Factory.

Terminals

Gold-coated PC terminals or solder hook style. PC pins fit .100 grid spacing. Terminal mounting options available.

Weight (approx.)

Metal shaft & bushing: (Single) .19 oz., (Dual) .27 oz., (Triple) .35 oz.

*T.M. Dow Chemical Co.

**T.M. DuPont

Mechanical Specifications continued, next column

Series 408/409 Operational Specifications

Operating Temperature Range

Series 408: -40°C to +120°C

Series 409: -40°C to +150°C

Storage Temperature Range

Series 408: -55° to +120°C

Series 409: -55°C to +150°C

Rotational Life

Series 408: linear control, 50,000 cycles under load, (plain bushing).

Change not to exceed 10% R.

Trimmer life under load is 5,000 cycles.

Series 409: linear control, 25,000 cycles under load, (plain bushing).

Change not to exceed 5% R.

Trimmer life under load is 5,000 cycles.

AL Switch Specifications

Rating

125ma 28Vdc (dry circuit)

Rotational Life

25,000 cycles under rated load

BL and BLM Switch Specifications

Rating

250ma 30Vdc (dry circuit)

Rotational Life

15,000 cycles under rated load

Figure 1

Chart A

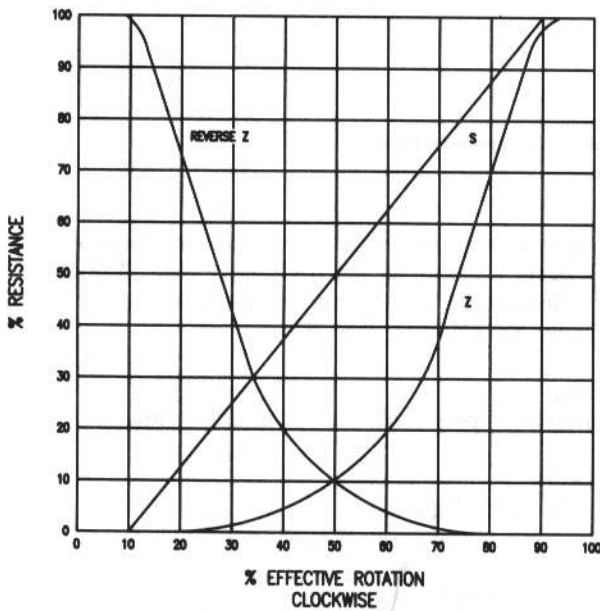

Curves Standard

The "S" taper is linear, the change in resistance value being directly proportional to the degree of rotation. It can be used either as right-hand or left-hand taper.

The "Z" taper attains 10% resistance value at 50% of clockwise rotation (left-hand).

The reverse "Z" taper attains 10% resistance values at 50% of counter-clockwise rotation (right-hand).

For conformity and special output curves, consult Factory

Figure 2

Chart B

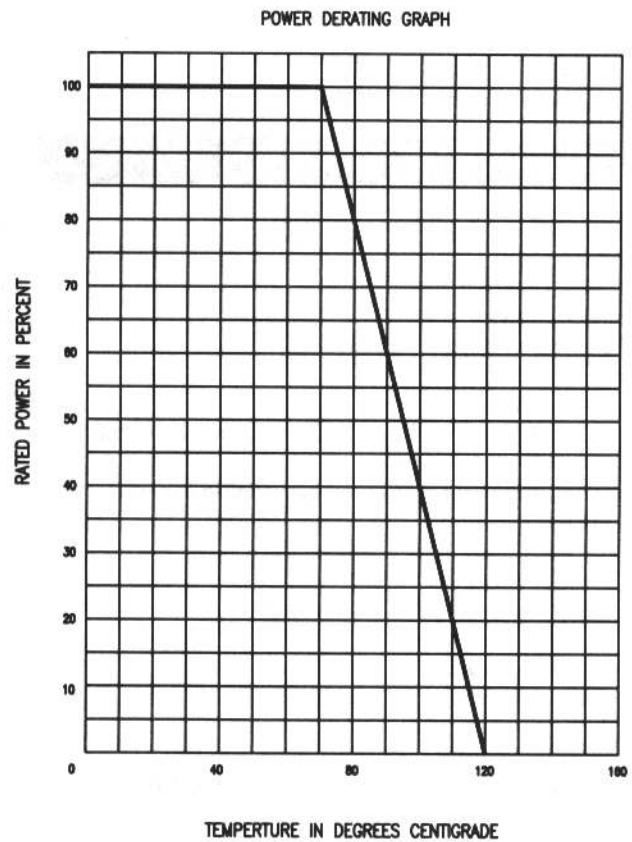
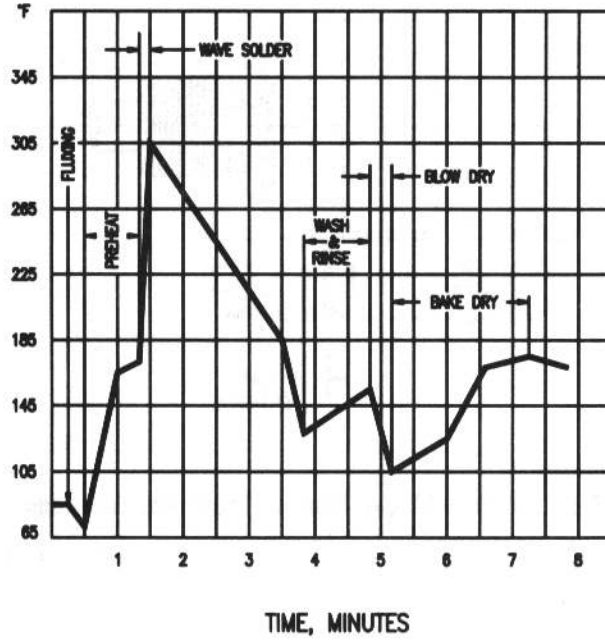

Figure 3
Chart C

Nominal Resistance	Maximum Percent Temporary Resistance Change From 25°						
	-55°C	-40°C	0°C	+25°C	+55°C	+85°C	+120°C
100 Ohms	±5.0	±4.0	±1.5	0	±1.5	±2.0	±3.5
10k Ohms	+7.0	+5.5	+2.0	0	±1.5	±2.5	±5.5
100k Ohms	+8.0	+6.0	+2.5	0	±2.0	±3.5	±6.0
1 Megohm	+10.0	+8.0	+3.0	0	±2.5	±4.0	±7.5

For non-linear tapers, multiply chart values by 1.25.

Figure 4
Chart D



Wave Solder and Board Wash Parameters Recommended Profile, Temperature on PC Board

Process Limits	Temp.	Time
Preheat Maximum	195°F	1 Min.
Solder Temperature Maximum	550°F	
Maximum Differential Temperature After Solder Into Wash (3/4T)	72°F	
Wash Temperature	150-160°F	1-1/2Min.
Dry Temperature	160-220°F	2 Min.

Tolerance specifications apply to all layout drawings unless otherwise specified:
fractions $\pm 1/64$ in. (.379mm);
 $\pm 1/32$ in. (.794mm) over 1 in. (25.4mm);
decimals $\pm .005$ in. (.127mm);
PC board layout $\pm .010$ in. (.254mm).

Figure 5
Series 408/409

Single, Dual or Triple
(Second or Third Section May Be AL Series Rotary Switch)
Printed Circuit - Type B-22
"C" Terminal Length: .875" (22.3mm) Maximum
Standard PC Terminal Length: .250" (6.36mm)

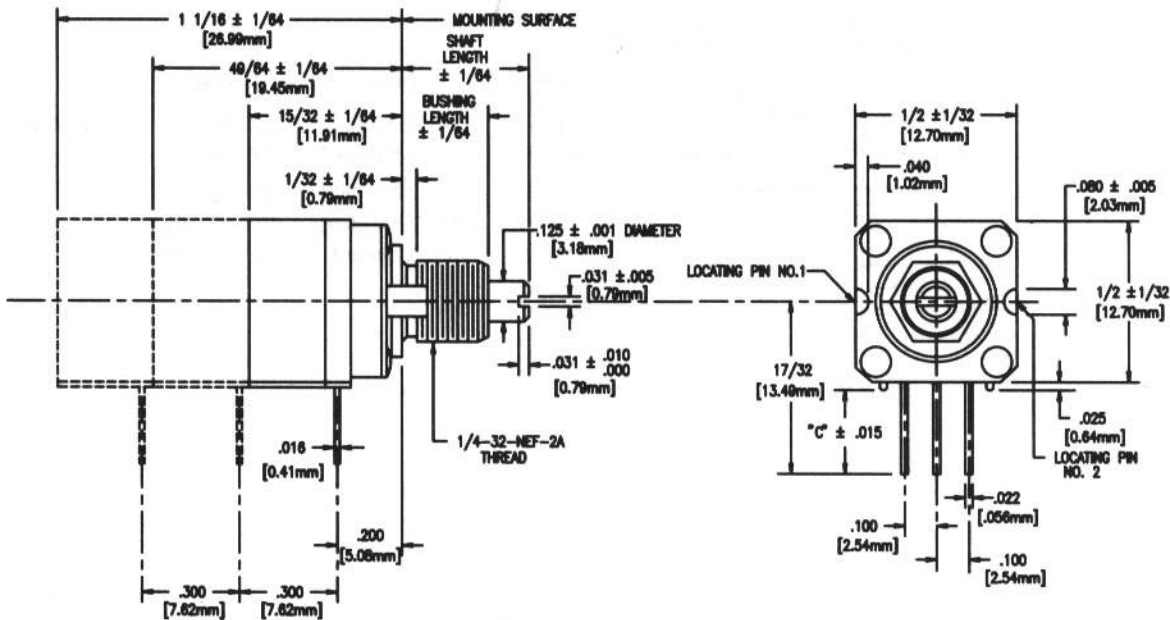

Figure 6

Series 408/409 Solder Lug Terminals

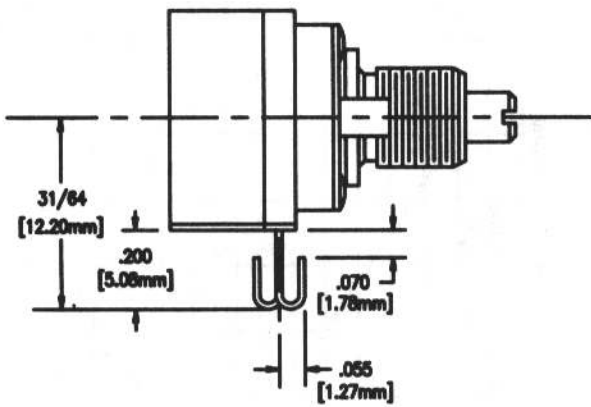

Figure 7

Series 408/409 Bushingless Trimmer

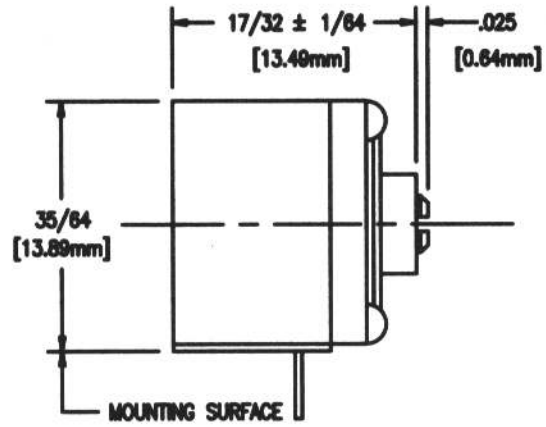
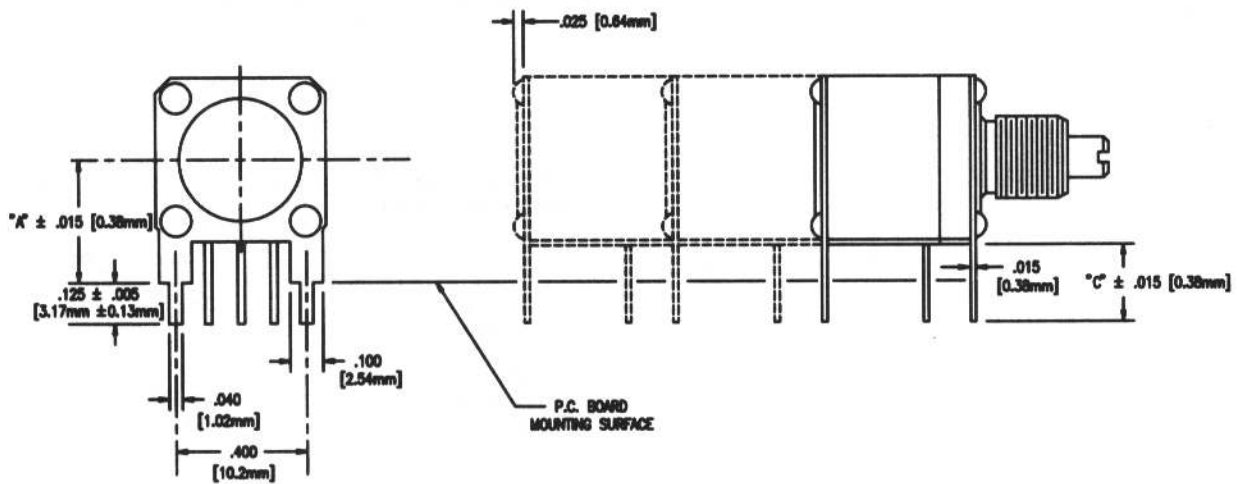
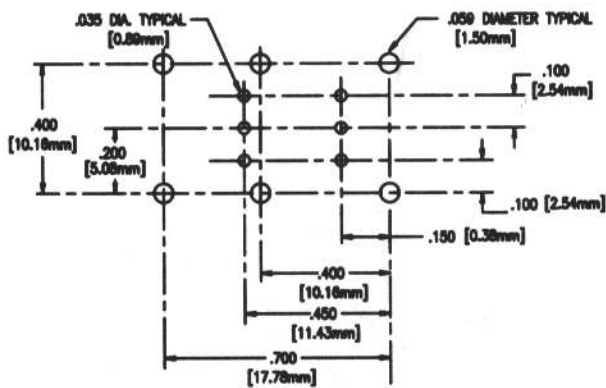

Figure 8

Series 408/409 Single, Dual, or Triple with Panel and Rear Support Plates, Horizontal Mounting



PC Board Layout



TYPE	"A" (PLATE)	"C" (TERMINAL)	STANDARD
B-24-1	3/8 [9.52mm]	.250 [6.35mm]	STANDARD
B-24-2	1/2 [12.70mm]	.375 [9.40mm]	
B-24-3	5/8 [15.88mm]	.500 [12.70mm]	
B-24-4	3/4 [19.05mm]	.625 [15.88mm]	
B-24-5	.255 [6.48mm]	.125 [3.18mm]	

Figure 9
Series 408/409 Pot and BL Series Push-Pull or BLM Momentary
Switch Printed Circuit Board Layout (Available with B-24 Support
Plates)

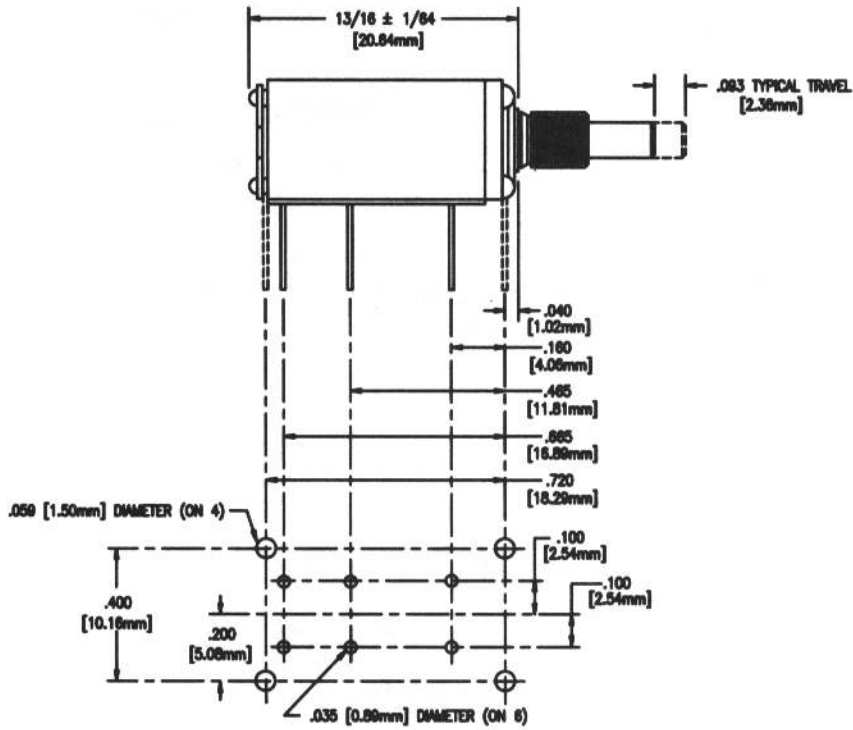
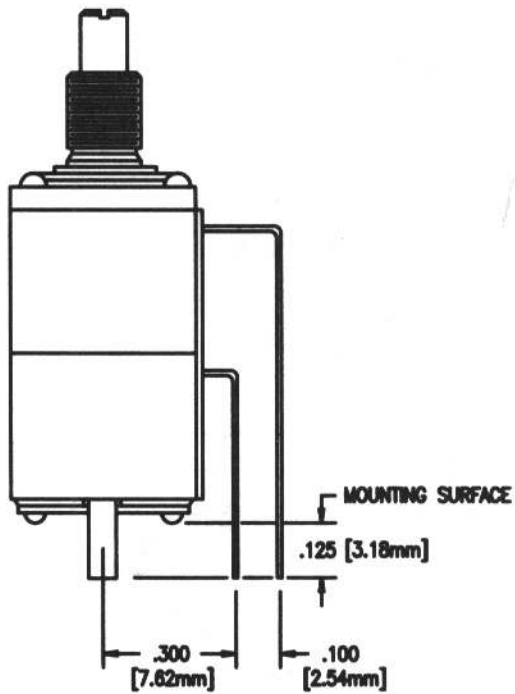

Figure 10
Series 408/409 Type C-10 Printed Circuit Terminals



P.C. BOARD LAYOUT

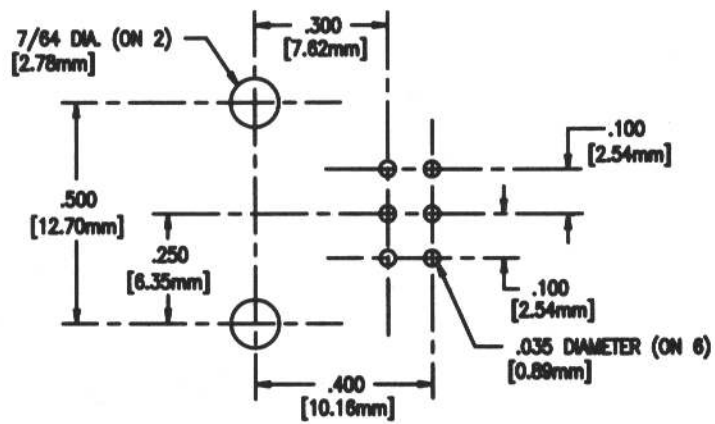

Figure 11

Series 408/409 Type A-18 Printed Circuit Terminals

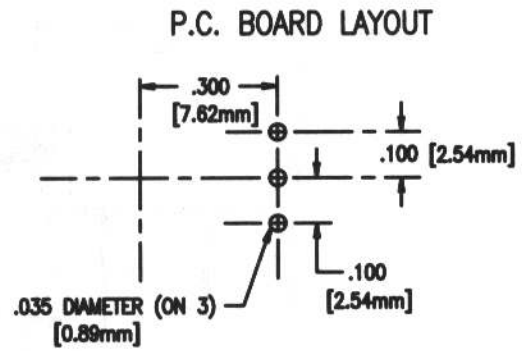
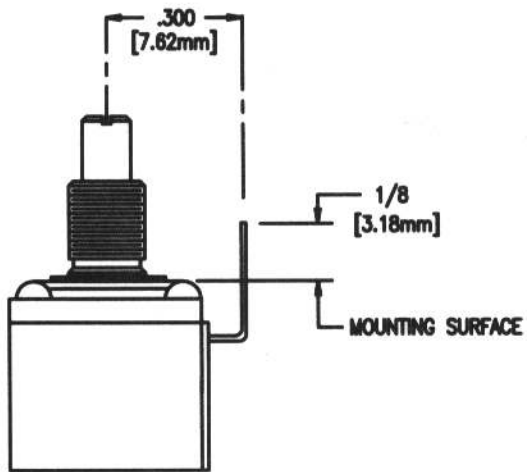
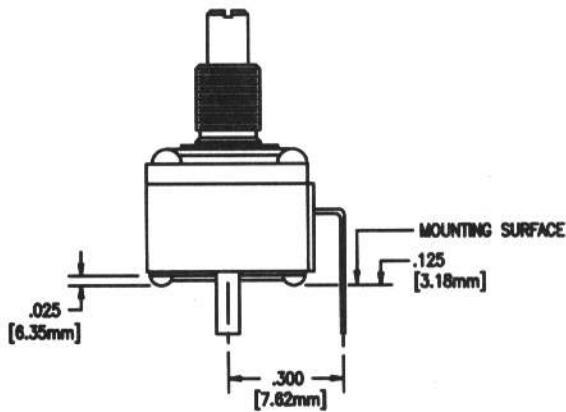

Figure 12

Series 408/409 Type C-8 Printed Circuit Terminals



PC BOARD LAYOUT

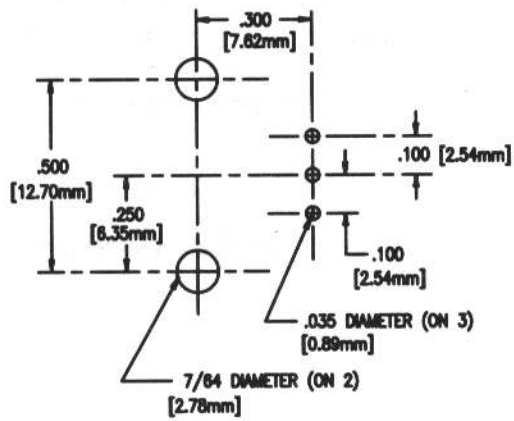
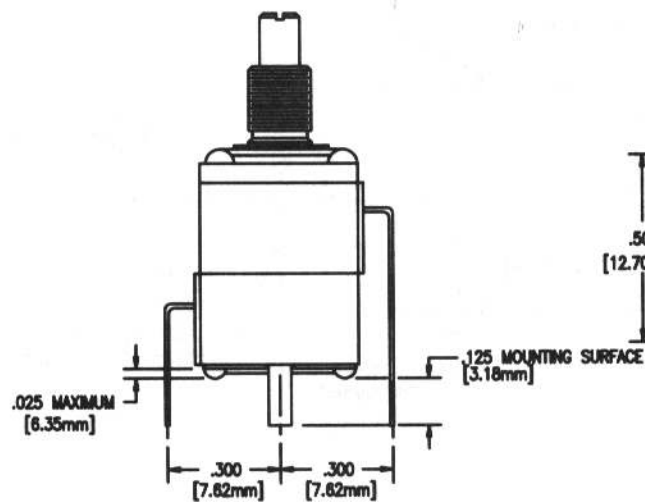

Figure 13

Series 408/409 Type C-9 Printed Circuit Terminals



P.C. BOARD LAYOUT

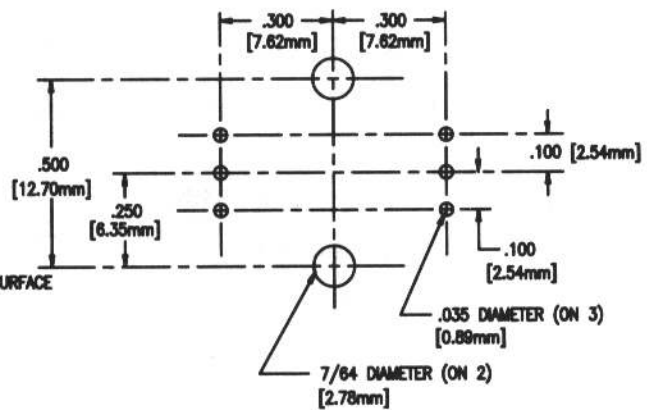
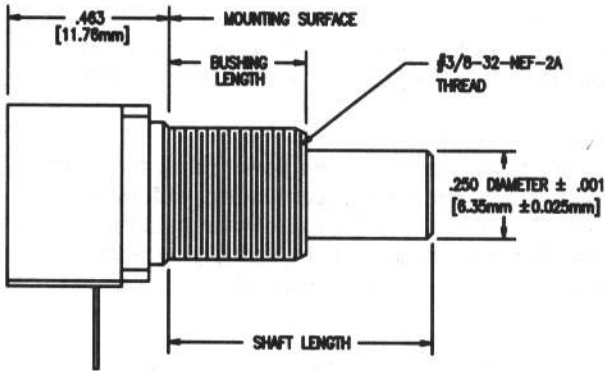

Figure 14

Series 408/409 (See Figure 4 for other dimensions)

1/4 in. (6.35 mm) Diameter Shaft
 3/8 in. (9.53 mm) Diameter Bushing



Standard Resistance Values continued

D408N(RZ) (Same resistance & taper in both sections)

500	10K	50K
1K	25K	100K

D408N (Z/RZ) (Same resistance both sections. Panel Z taper, rear RZ taper.)

1K	10K	50K
5K	25K	

409N

100	2.5K	50K	1Meg
250	5K	100K	2.5Meg
500	10K	250K	5Meg
1K	25K	500K	

409N(Z)

1K	5K	50K
2.5K	10K	

SUPPORT MOUNTING (Optional)*

Catalog Number	"A" (Plate)	"C" (Terminal)
B-24A-1	.375	.250
B-24A-2	.500	.375
B-24A-3	.625	.500
B-24A-4	.750	.625
B-24A-5	.255	.125

*Rear plate only.

Series 408/409 Standard Resistance Values

Stock Values (Ohms)

408N			
100	2.5K	50K	1Meg
250	5K	100K	2.5Meg
500	10K	250K	5Meg
1K	25K	500K	

408N(Z)			
1K	10K	50K	
5K	25K	100K	

408N(RZ)			
500	10K	50K	
1K	25K	100K	

408NS			
100	1K	10K	100K
500	5K	50K	

408NS(Z)			
1K	10K	50K	
5K	25K	100K	

408NPPS			
100	1K	10K	50K
500	5K	25K	100K

408NPPS(Z)			
500	5K	25K	100K
1K	10K	50K	

D408N (Same resistance in both sections)			
100	2.5K	50K	1Meg
250	5K	100K	2.5Meg
500	10K	250K	5Meg
1K	25K	500K	

D408N(Z) (Same resistance & taper in both sections)			
500	5K	25K	100K
1K	10K	50K	

Series 408/409 How To Order

Example: **D408-N-PPS-100K-Z**

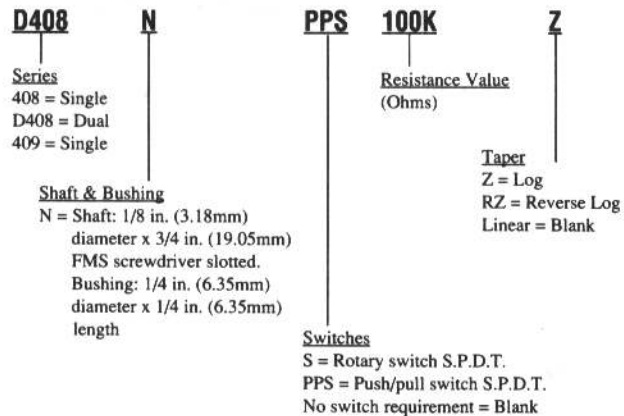

Standard Resistance Values continued, next column