

# SENASYS

## Thermostat Catalog 2004

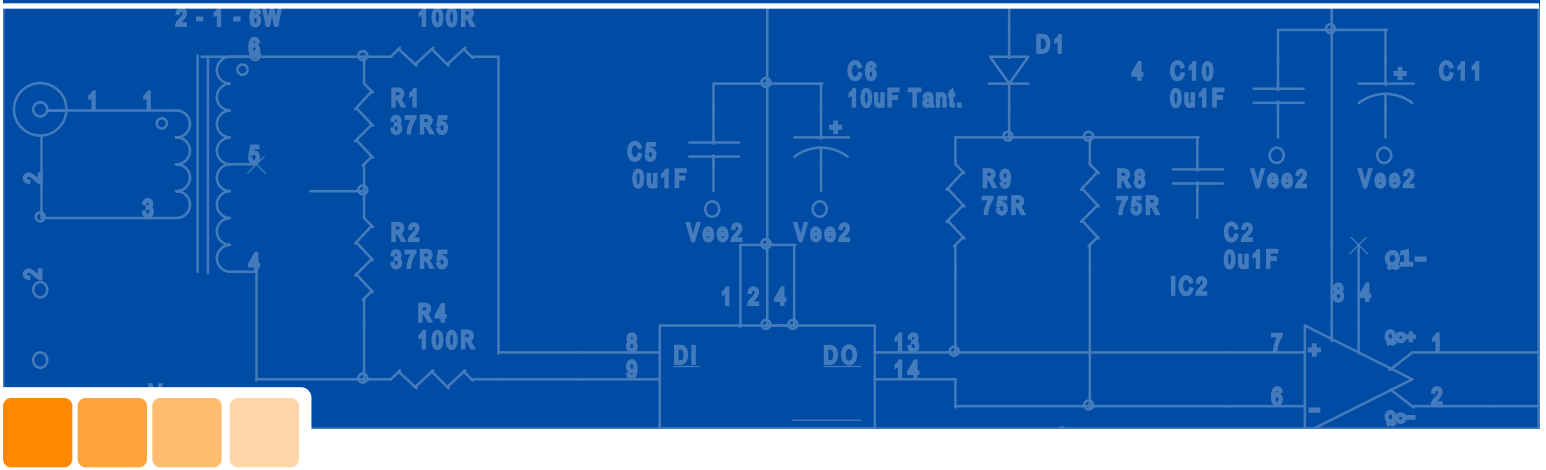

# SERIES 2500

## 3/4" 25Amp THERMOSTATS

### Typical Applications:

- HVAC Equipment
- Major Appliances
- Industrial Equipment
- Food Service Products

Senasys 2500 Series Thermostats are quality-engineered thermal sensors specifically designed for a variety of major appliances, including clothes dryers, hot liquid and food-dispensing machines, room unit and space heaters, air conditioning systems, copy machines, engine heaters, and wood stoves.

Made to open or close on a temperature rise, the 3/4" Thermostat is rated at 25 AMPS-240 Volts, meets UL Standards 873 and 353 and is available in a single-pole, single-throw device. Temperature calibrations are preset, and all units are subject to 100% mechanical and thermal inspection.

To insure that a safe combination of thermostat and application is achieved, the purchaser must determine product suitability for their individual requirements.

### UL and CSA Listings

UL and CSA listing of 2500 series thermostats is for use in equipment where the acceptability of the combination of the thermostat and equipment is determined by Underwriter's Laboratories, Inc. and/or Canadian Standards Association.

<b>2500 Series</b>	UL File MH8267 CSA File LR21048 Consult Factory for Updated Listings
--------------------	--

### Key Features and Benefits:

- Recognized by UL, CSA and European Approval Agencies
- Meets UL Standard 873 and 353
- Manufactured to individual temperature specifications
- Available in a variety of terminal and mounting configurations

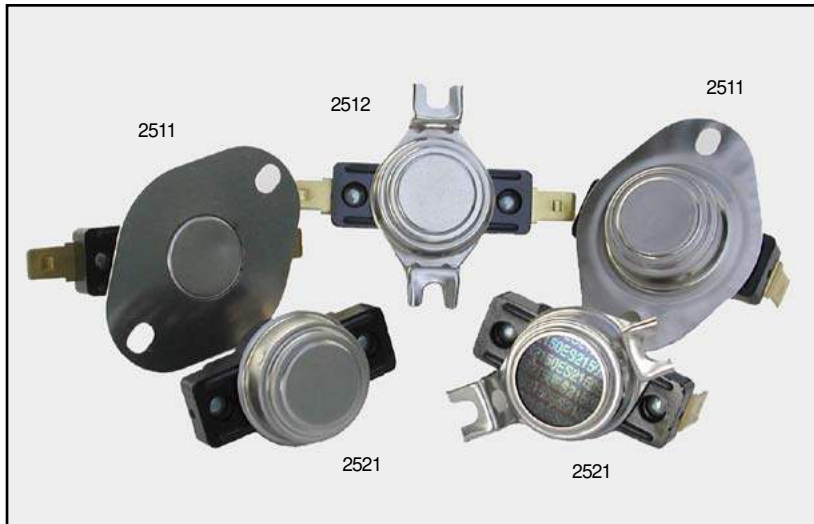

**Standard Temperature Settings**

Temperature Set Point Ranges If unit falls in overlapping range use higher range	Tolerance Allowance° ± at temperature set points		Mean Differential Number of degrees between opening and closing nominal temperatures				Price Group*
	Open ±°F	±°C	Close ±°F	±°C	°F	°C	
<b>0 to 79°F</b> <b>-18 to 26°C</b>	6	3	6	3	10 to 14	5 to 7	IV
	6	3	6	3	15 to 19	8 to 11	III
	6	3	6	3	20 to 29	12 to 16	II
	7	4	6	4	30 to 39	17 to 22	I
	8	4	9	5	40 to 59	23 to 33	I
	9	5	10	6	60 to 80	34 to 35	II
<b>80 to 200°F</b> <b>27 to 82°C</b>	5	3	5	3	10 to 14	5 to 7	IV
	5	3	5	3	15 to 19	8 to 11	III
	5	3	7	4	20 to 29	12 to 16	II
	6	3	7	4	30 to 39	17 to 22	I
	6	3	9	5	40 to 59	23 to 33	I
	8	4	10	6	60 to 80	34 to 35	II
<b>201 to 250°F</b> <b>83 to 121°C</b>	5	3	6	3	15 to 19	8 to 11	III**
	5	3	7	4	20 to 29	12 to 16	II
	6	3	8	4	30 to 39	17 to 22	I
	7	4	9	5	40 to 59	23 to 33	I
<b>251 to 350°F</b> <b>122 to 150°C</b>	6	3	8	4	20 to 29	12 to 16	II
	7	4	9	5	30 to 39	17 to 22	I
	8	4	11	6	40 to 59	23 to 33	I
	9	5	13	7	60 to 80	34 to 35	II

**B501 Cap Small Flange**

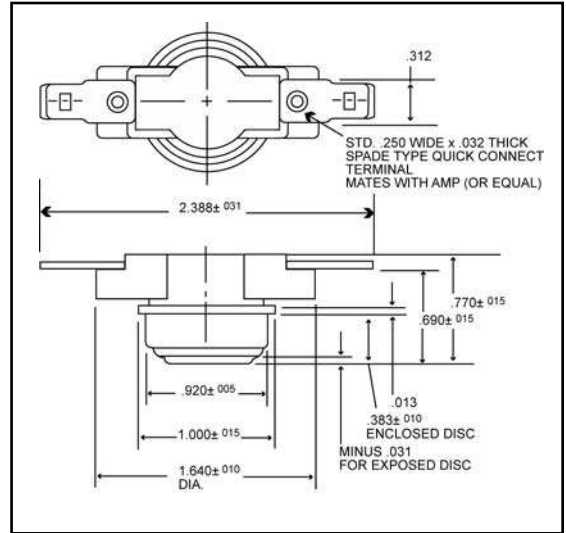

\*Grouped according to level of accuracy required. Group I with greatest latitude is less expensive than Group II, etc.

\*\*With 15 to 19°F Differential-Maximum Set Point 220°F

**CALIBRATION TEMPERATURES**

The temperature tolerance and differentials listed above are standard. If your requirements are not listed, please consult the factory. The "differential" is the number of degrees between the nominal open and nominal close. For example: A thermostat calibrated to open at 170°F ± 9°F has a 40°F temperature differential.

**2500 Series**

**3/4" DISC THERMOSTAT TEMPERATURE EXPOSURE: 350° F MAX.**

Model	Type	Clearance	Cycles	RES AMPS	120 Volts AC 1 Ø IND.			VA Pilot Duty	RES AMPS	240-250 Volts AC 1 Ø IND.			RES AMPS	277 Volts AC 1 Ø IND.			VA Pilot Duty	480 Volts AC RES AMPS	1 VDC to 50 VDC	12 VDC RES AMPS	120 Volts AC IND AMPS
					HP	FLA	LRA			HP	FLA	LRA		HP	FLA	LRA					
2511	L AND F	1/8 Air	100,000	25	1/2	10	60	200	25			406	22			406	13			15	
		1/4 Surface	30,000	25		16	84	200	25	8	42	406	22	8	42	406	13		30		
2521		1/4 Air 3/8 Surface																			
2512	L AND F	1/8 Air	100,000	15	1/6	4.4	26.4	125	15	1/16	2.2	13.2	125	10		125				15	
		1/4 Surface																			
2522		1/4 Air 3/8 Surface	6,000	15	1/4	5.8	34.8	125	15	1/4	2.9	17.4	125								
2519 <b>Gold-Plated</b>	L AND F	1/8 Air	100,000	0.1														0.1			
		1/4 Surface	30,000																		
2529		1/4 Air 3/8 Surface	6,000															1.0		1.0	

Contacts are available for millivolt and milliamp applications. Consult factory for exact approval agency listings.

# SERIES 2500

## TERMINAL & BRACKET OPTIONS

### Dimensional Specifications

#### B502 Cap Large Flange

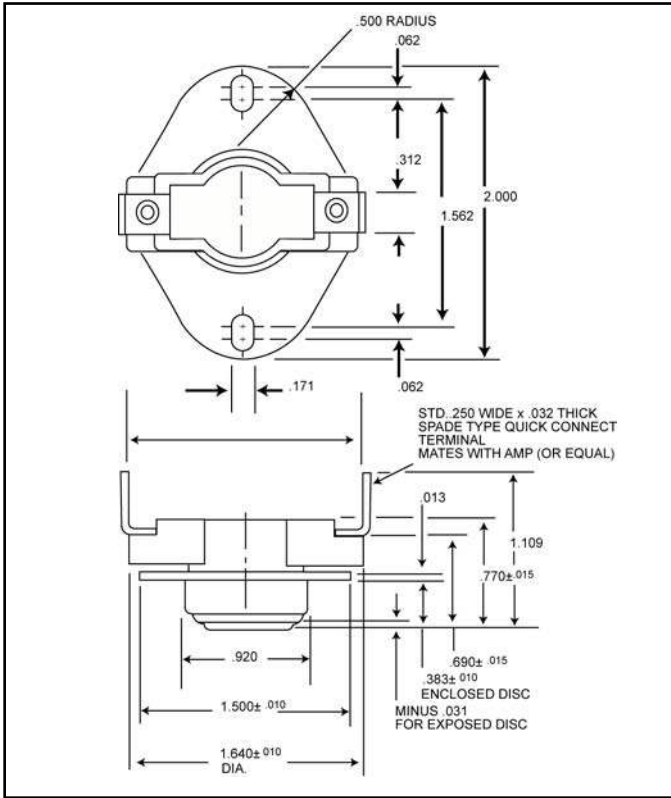

#### B503 Bracket

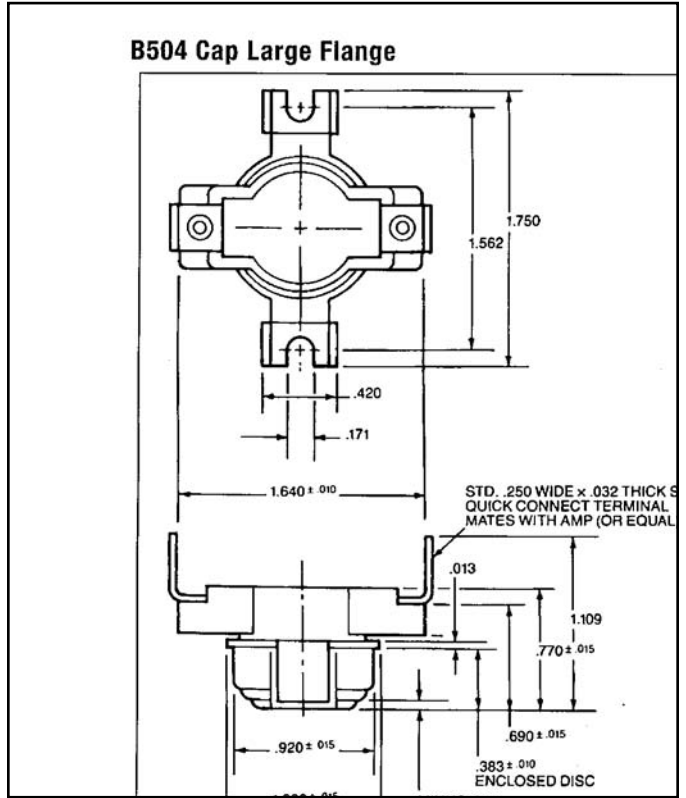

#### B504 Cap Large Flange

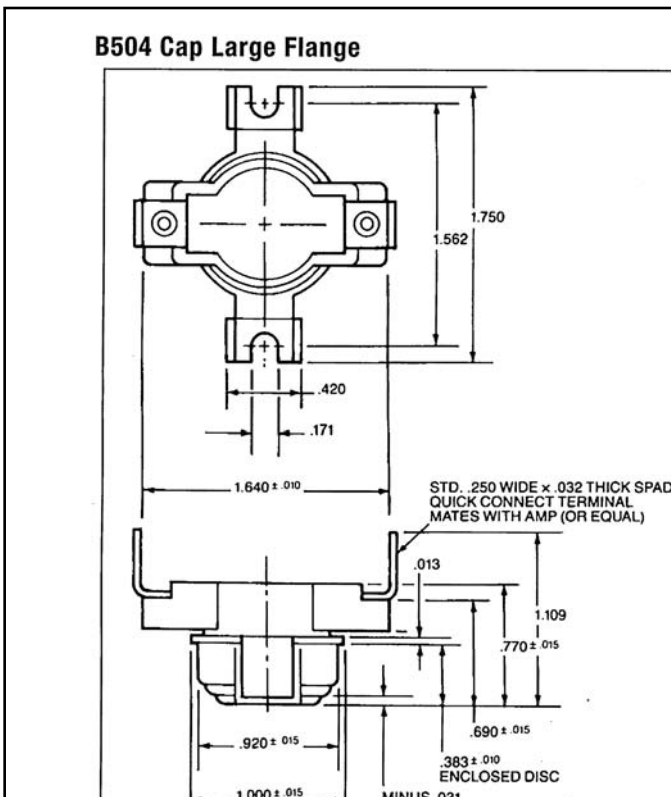

#### B507 Bracket

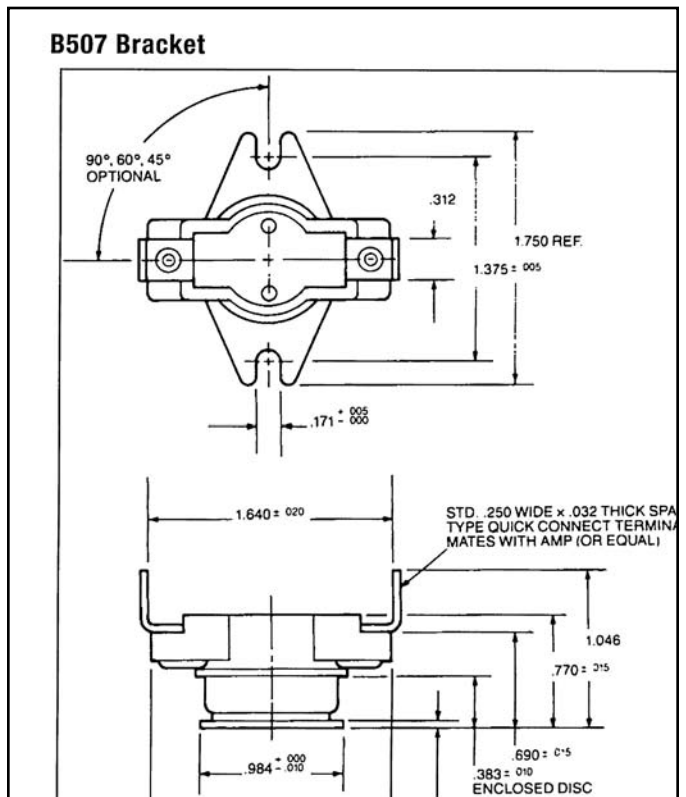

# SERIES 2500

## TERMINAL & BRACKET OPTIONS

### Terminals

T501 0° As Shown

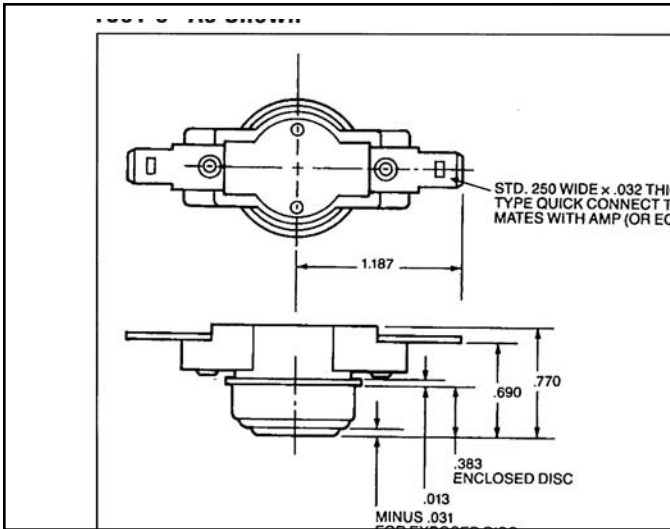

T507

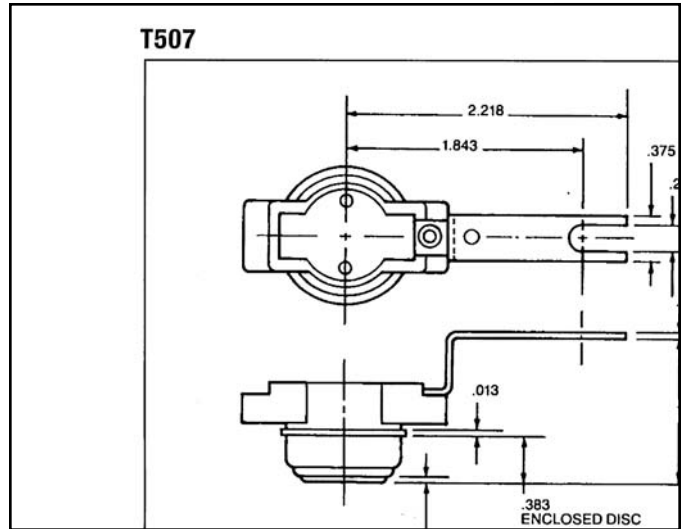

T502

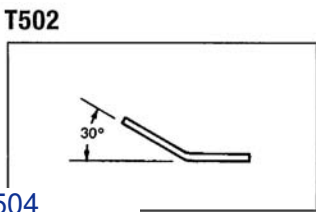

T503

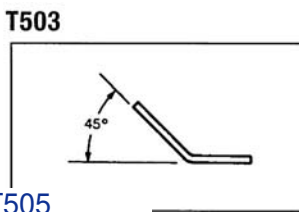

T504

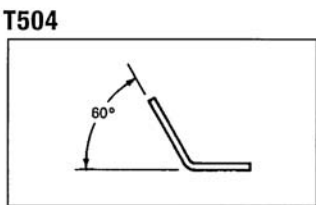

T505

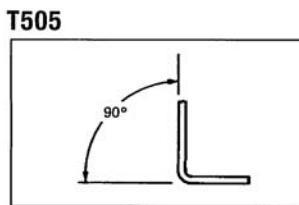

T508 0° As Shown

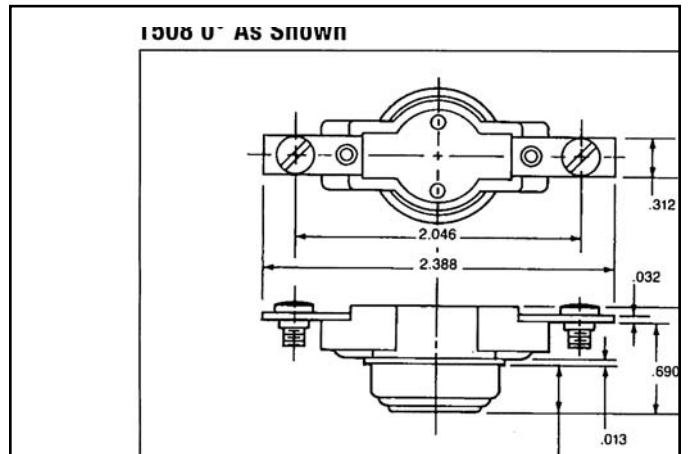

T506 0° As Shown

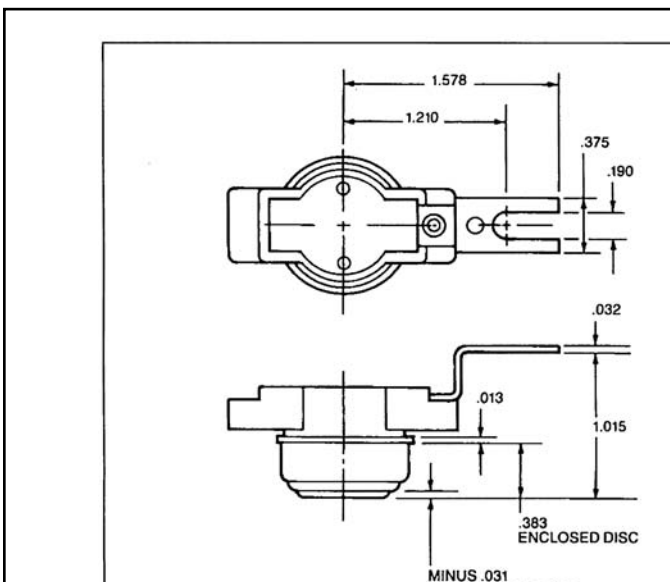

T509

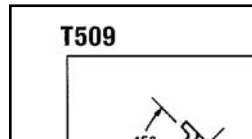

Screws (Please Specify if Needed When Ordering)

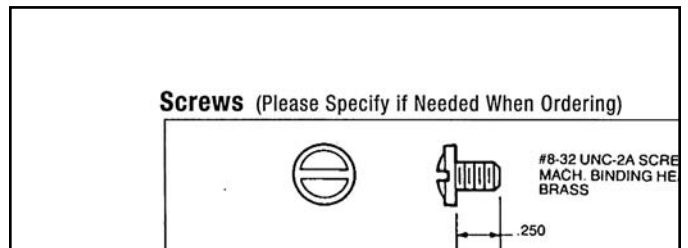

### Thermostat Operation

When contacts are closed, current passes from terminal to terminal through the stationary contact to the movable contact which is actuated by the snap movement of the bimetal disc. The disc, which is fully insulated from the switch chamber by the pin and disc retainer, is affected by surface or ambient temperature changes. Upon reaching the opening temperature, the disc snaps from a convex to a concave shape, depressing the pin which opens the contacts. The open circuit allows the temperature to drop and causes the disc to snap to its original position, closing the contacts. A thermostat which closes on a rise in temperature operates in a similar manner, but in reverse action.

### Location and Selection of Components

A thermostat can be used to control temperature, to warn in advance of temperatures beyond desired limits, or to shut down an entire system. Response, accuracy, sensitivity, and the ability to sense the thermal parameter in a system depends on the proper selection of a thermostat and its application with respect to location, heat source, electrical load, transfer media, thermal lag, and the design life of the system. Samples of working thermostats or special thermostats with thermocouples installed are available to help you determine the proper combination of location and temperature set points.

### Application Parameters

Proper choice of operating temperatures for a thermostat generally depends on many application parameters. The following can have a significant effect on the final operating point of the application:

1. Rate of Temperature Rise
2. Location of the Thermostat
3. Electrical Load
4. Mass of the Thermal System
5. Heat Transfer Medium (air, metal surface, etc.)

Because of these variables, we recommend

that initial testing be performed with thermocouple samples to minimize trial and error when choosing final temperatures and tolerances. When requesting thermocouple samples please specify Iron or Copper Constantan and Lead Length.

### SENASYS Sensors Part Number

A complete SENASYS part number consists of 3 parts. (Example: <sup>(1)</sup>2511 <sup>(2)</sup>F002-<sup>(3)</sup>2015) The first group specifies the series. The second group identifies the terminal and bracket combination desired and is generally unique to that series only. The last group is sequentially assigned by SENASYS Sensors' Application Engineering Dept., and defines the temperature parameters, etc., unique to that device.

### Testing Procedures

Temperature testing is performed using either liquid or air as a test medium. To allow for variation in temperature checking methods, a 1°C allowance should be considered. This allowance is for correlation or differences between test instruments. Manufacturing specifications and production testing are to specified requirements and do not make use of the correlation variance.

Creep testing is the verification of an instantaneous change of state of the electrical contacts.

The Dielectric withstand voltage test (Hipot) is performed at a higher voltage for a short duration than the rated voltage of the thermostat. This helps assure satisfactory performance at rated voltage and also the ability of the unit to withstand momentary overpotentials. This test also serves to determine whether insulating materials and spacing are adequate.

### Samples and Ordering

To order samples please refer to the form on the inside back cover. If you need assistance call us at (888) 736-2797, or e-mail us at support@senasys.com.

### Definitions

**Automatic Reset:** A type of thermostat that will reset itself at a specific temperature; (i.e. a thermostat opens at 150°F and closes or resets itself at 120°F)

**Bimetal:** Two dissimilar metals bonded together to form the disc that actuates the thermostat; upon reaching a specified temperature, the disc snaps over the center.

**Close On Rise:** (COR) refers to operation of the contacts. When the temperature rises to its set point the contacts close or make contact and complete the circuit.

**Dielectric Strength:** Is the deliberate application of a pre-determined overvoltage to a thermostat for specified time.

**FLA:** (Full Load Amps) current taken from line by motor when motor is yielding rated hp at rated voltage and frequency.

**Manual Reset:** A bimetal thermostat with a reset button that must be pressed to reset the device.

**Max. Differential:** The maximum allowable difference between the actual opening and the actual closing temperatures.

**Mean Differential:** The difference between the upper and lower nominal set points without regard to tolerances.

**Min. Differential:** (Sometimes called “Deadband”) The minimum allowable difference actual opening temperature and the actual closing temperature.

**Open On Rise:** (OOR) refers to the operation of contacts—when the temperature rises to its set point, the contacts open terminating the circuit.

**Phenolic:** A plastic used as the insulating body of the thermostat.

**Set Point:** The nominal temperature at which the thermostat is to open or close.

**SPST:** (Single Pole/Single Throw) an electrical switch with one set of terminals that terminate or actuate a circuit.

**Tolerance:** The allowable range above and below the set point temperature.

### Quality Control and Application

The entire production process from preassembly to shipping of the final product is supervised by a staff of quality control personnel. Specifications and performance characteristics of SENASYS, Inc. stated herein or in any other SENASYS communication are based upon various testing and quality control procedures established by SENASYS. Information regarding such procedures will be provided upon request. SENASYS reserves the right to alter specifications contained herein as it may deem necessary. Purchasers are advised to test and engineer their products and the application of SENASYS's products, particularly where the application is one wherein a malfunction could result in damage or injury. Whenever SENASYS provides analysis or information to assist a purchaser in the application of SENASYS's products, such analysis or information shall not affect any of the foregoing nor shall it constitute a warranty of any kind with respect to said application. Sales by SENASYS are subject to standard terms and conditions set forth in its sales documents. Electrical rating and performance characteristics have been established after testing and review of standard operating conditions. The specifications outlined in the bulletin suggest the performance characteristics when the units are subject to these standard conditions. To ensure that our laboratory test conditions duplicate the performance requirements for the application, all devices should be tested by the purchaser for each application. Terms of all sales be as provided in SENASYS, Inc. standard terms and conditions of sale, including its limited warranty provisions.

# REQUEST FOR SAMPLES OR QUOTATION

**DO NOT DETACH!**  
**Photocopy & Fax**  
**to SENASYS**  
**(419) 818-0897**

For information on other  
SENASYS products

CMC Multi-Light  
Control Switches

P-Series Controls

Company \_\_\_\_\_ Telephone \_\_\_\_\_

Name \_\_\_\_\_

Street \_\_\_\_\_

City \_\_\_\_\_ State/Zip \_\_\_\_\_

Describe the Application: \_\_\_\_\_

**New Product**       **Existing Product**

Thermostat Function:     High Limit       Control       Manual Reset

Ambient Conditions:

Exposure Temperature Maximum \_\_\_\_\_ °F, Duration \_\_\_\_\_

Minimum \_\_\_\_\_ °F, Duration \_\_\_\_\_

Temperature Rate of Rise \_\_\_\_\_ °F per minute \_\_\_\_\_

Environmental Seal       Hermetic       Dust Proof       Unsealed

Electrical Load:

Voltage \_\_\_\_\_       AC       DC

Resistive \_\_\_\_\_ AMPS      Inductive \_\_\_\_\_ F.L.A. \_\_\_\_\_ L.R.A. \_\_\_\_\_

Dielectric \_\_\_\_\_ Megohm \_\_\_\_\_

Life Cycles at Specified Load \_\_\_\_\_ Cycles

Thermostat Specification:

Contact Open \_\_\_\_\_ °F ± \_\_\_\_\_ °F Tolerance

Contacts Close \_\_\_\_\_ °F ± \_\_\_\_\_ F Tolerance (automatic reset only)

Contacts Close Manually (                      ) Resettable By \_\_\_\_\_ °F

Part Number:    SENASYS # \_\_\_\_\_      Customer# \_\_\_\_\_

Mounting Bracket # \_\_\_\_\_      Terminal Type \_\_\_\_\_

Exposed Bimetal       Enclosed Bimetal

Sample Quantity:

\_\_\_\_\_ units      Delivery Requested \_\_\_\_\_

Production:

Estimated Usage \_\_\_\_\_      Annually, Start Date \_\_\_\_\_

One Time Order Quantity \_\_\_\_\_

Agency Approvals:

UL     CSA    Other \_\_\_\_\_

Quotation Requested:

Yes     No      Quantity \_\_\_\_\_

For special configurations, please provide a sketch.



704 Bartlett Avenue  
Altoona, WI 54720  
Tel. (715) 831-6353  
Toll Free: 1-888-736-2797  
Fax: (419) 818-0897

[www.senasys.com](http://www.senasys.com)  
[support@senasys.com](mailto:support@senasys.com)